

**Determining the functions of transcriptional regulatory
genes of the *npd* gene cluster encoding 2,4,6-trinitrophenol
degradation in *Rhodococcus opacus* HL PM-1**

Von der Fakultät für Geo-und Biowissenschaften der Universität Stuttgart
zur Erlangung der Würde eines Doktors der Naturwissenschaften
(Dr. rer. nat) genehmigte Abhandlung

Vorgelegt von
Dang Phuong Nga
aus Hanoi, Vietnam

Hauptberichter	Prof. Dr. H.-J. Knackmuss
Mitberichter	Prof. Dr. G. Sprenger
Tag der mündlichen Prüfung	11.06.2004

Institut für Mikrobiologie der Universität Stuttgart
2004

Contents

Abbreviations

Abstract.....	1
Zusammenfassung	3
1. Introduction	5
1.1. DNP and TNP in the environment	5
1.2. DNP and TNP degradation by bacteria.....	6
1.3. Gene regulation of nitroarene degradation.....	10
1.4. Significance and aim of this work.....	11
2. Materials and methods.....	13
2.1. Bacteria and plasmids	13
2.2. Media, buffers and solutions.....	15
2.2.1. Media.....	15
2.2.2. Buffers and solutions.....	17
2.3. Strain storage and culture condition.....	22
2.3.1. Strain storage	22
2.3.2. Culture condition	22
2.3.3. Resting cells.....	23
2.4. Molecular genetic methods.....	23
2.4.1. Isolation of genomic DNA	23
2.4.2. Isolation of plasmid DNA	24
2.4.3. Isolation of RNA	24
2.4.4. Determination of DNA/RNA concentration.....	25
2.4.5. Electrophoresis of nucleic acids	25
2.4.6. Phenol extraction of DNA	27
2.4.7. Precipitation of DNA.....	28
2.4.8. Enzymatic manipulations of DNA	28
2.4.9. Transfer of DNA into <i>E. coli</i> or <i>Rhodococcus</i>	30
2.4.10. Gel mobility shift assay	32
2.4.11. Polymerase chain reaction	33
2.4.12. Transferring DNA to nylonmembrane	36
2.4.13. Hybridisation	38

2.4.14. Sequencing	39
2.4.15. Computer analysis	40
2.5. Protein analytical methods.....	40
2.5.1. Preparation of crude extract.....	40
2.5.2. Determination of protein concentration.....	40
2.5.3. Determination of nitrite concentration	41
2.5.4. High performance liquid chromatography	41
2.5.5. SDS - Polyacrylamide gel electrophoresis	41
2.5.6. Enzyme assays.....	42
2.5.7. Purification of proteins	44
2.6. Chemicals and biochemicals.....	44
3. Results	45
3.1. Promoter regions in the <i>npd</i> gene cluster.....	45
3.1.1. Consensus sequences in the <i>orfA-orfB</i> and <i>npdH-npdI</i> intergenic regions	45
3.1.2. Expression of <i>xylE</i> under the control of IGRI' and IGRIV'	45
3.2. Characterisation of <i>npdR</i> and the encoded repressor in <i>R. opacus</i> HL PM-1	47
3.2.1. Heterologous expression of <i>npdR</i> in <i>E. coli</i>	47
3.2.2. Purification of NpdR from <i>E. coli</i>	48
3.2.3. Binding of NpdR to DNA regions within IGRI' and IGRIV'	49
3.2.4. Binding of the purified His-tag fusion NpdR to IGRI' and IGRIV'	50
3.2.5. Effect of DNP on DNA-NpdR complex formation.....	51
3.2.6. Effect of analogous nitrophenol compounds on DNA-NpdR complex formation.....	52
3.2.7. Identification of operator regions within IGRI' and IGRIV'	53
3.2.8. Creating an unmarked <i>npdR</i> deletion in <i>R. opacus</i> HL PM-1	54
3.2.9. Characterisation of <i>npdR</i> deletion mutant	56
3.2.10. Effect of NpdR on gene expression from IGRI' or IGRIV'	58
3.3. Determination of a putative promoter region in IGRII.....	59
3.4. Alternative inducers of TNP degradation	60
3.4.1. Induction of <i>npdC</i> at the transcriptional level	60
3.4.2. Induction of <i>npdC</i> or <i>npdI</i> in <i>R. opacus</i> HL PM-1 at the translational level	61
3.4.3. Conversion of TNP by resting cells of <i>R. opacus</i> HL PM-1 after inducing the cultures with various inducers	62

3.4.4. Inducibility of <i>npd</i> genes in other DNP degrading strains	64
3.5. Identification of the function of <i>orfA1</i> and <i>orfA2</i> in TNP metabolism.....	65
3.5.1. Cloning and sequencing the 5' end of <i>orfA2</i>	66
3.5.2. Construction of deletion mutant strain for <i>orfA2</i>	69
3.5.3. Characterisation of deletion mutant <i>R. opacus</i> ND2.....	71
3.5.4. Expression of <i>orfA1</i> in <i>E. coli</i>	73
3.5.5. Construction of <i>orfA1</i> minus mutant	74
3.5.6. Characterisation of mutant <i>R. opacus</i> ND3.....	75
3.6. Localisation of the <i>npd</i> genes	77
3.6.1. Localisation of the <i>npd</i> genes in <i>R. opacus</i> HL PM-1.....	77
3.6.2. Localisation of the <i>npd</i> genes in <i>N. simplex</i> FJ2-1A.....	79
4. Discussion.....	81
4.1. <i>Rhodococcus</i> promoters in nitroarene degradation.....	81
4.2. IclR-type and LysR-type repressors in nitroarene degradation	82
4.3. Binding of IclR-type repressors to DNA-binding regions.....	84
4.4. Induction of nitroaromatic compounds degradation.....	86
4.5. Two-component regulators in <i>Rhodococcus opacus</i> HL PM-1.....	87
4.6. TNP-degradation genes on plasmid DNA	88
4.7. Future work.....	89
5. References	90
Acknowledgement.....	101
Curriculum Vitae.....	102

Abbreviations

2,4-DNCH	2,4-Dinitrocyclohexanone
2H ⁻ -DNP	Dihydride δ complex of DNP
2H ⁻ -TNP	Dihydride δ complex of TNP
4,6-DNH	4,6-Dinitrohexanoate
APS	Ammonium persulphate
ATCC	American Type Culture Collection
ATP	Adenosin-5'-triphosphate
(k) bp	(kilo) Base pair
BSA	Bovine serum albumin
C23DO	Catechol-2,3-dioxygenase
DEPC	Diethyl pyrocarbonate
DMF	N, N-dimethylformamide
DMSO	Dimethyl sulfoxide
DNA	Deoxyribonucleic acid
DNP	2,4-Dinitrophenol
dNTP	Deoxyribonucleoside triphosphate
DR	Direct repeat
EDTA	Ethylenediaminetetraacetic acid
GMSA	Gel mobility shift assay
h	Hour
H ⁻ -DNP	Hydride δ complex of DNP
HEPES	(4-(2-Hydroxyethyl) piperazine-1-ethanesulfonic acid
HPLC	High performance liquid chromatography
HTI / HTII	Hydride transferase I / II
HTH	Helix-turn-helix
H ⁻ -TNP	Hydride δ complex of TNP
IGR	Intergenic region
IGRI	Intergenic region between <i>orfA1</i> and <i>orfB</i>
IGRI'	157 bp, 3' end region of the intergenic region between <i>orfA1-orfB</i>
IGRII	Intergenic region between <i>npdF</i> and <i>npdR</i>

IGRIII	Intergenic region between <i>npdR</i> and <i>npdG</i>
IGRIV	Intergenic region between <i>npdH</i> and <i>npdI</i>
IGRIV'	Intergenic region between <i>npdH-npdI</i> plus the 3' end of <i>npdH</i>
IPTG	Isopropyl β -D-thiogalactoside
kDa	Kilodalton
M	Molar
min	Minute
MOPS	3-Morpholinopropanesulfonic acid
MPa	Megapascals
NADPH	Nicotinamide adenine dinucleotide phosphate
NBT	Nitroblue tetrazolium
NDFR	NADPH-dependent F ₄₂₀ reductase
PAGE	Polyacrylamide gel electrophoresis
PCR	Polymerase chain reaction
PEG	Polyethylene glycol
RNA	Ribonucleic acid
rpm	Revolutions per minute
s	Second
SDS	Sodium dodecyl sulphate
TEMED	N, N, N', N'-Tetramethylethylenediamine
TNP	2,4,6-Trinitrophenol (picric acid)
TNT	2,4,6-Trinitrotoluene
U	Unit
UV	Ultraviolet
v/v	Volume/volume
w/v	Weight/volume
X-Gal	5-Bromo-4-chloro-3-indolyl- β -D-galactopyranoside
X-Phosphate	5-Bromo-4-chloro-3-indolyl phosphate, toluidinium

Abstract

Rhodococcus opacus HL PM-1 utilises 2,4,6-trinitrophenol (TNP) and 2,4-dinitrophenol (DNP) as a sole carbon, nitrogen and energy source. The TNP metabolic enzymes are encoded by the *npd* gene cluster. The initial attack on TNP is two hydrogenation reactions, which are catalysed by hydride transferase I (encoded by *npdC*) and hydride transferase II (encoded by *npdI*) and the NADPH-dependent F₄₂₀ reductase (encoded by *npdG*).

In this work, three open reading frames, *orfA1*, *orfA2* and *npdR* were of interest. Database searches with the deduced amino acid sequences from *npdR*, *orfA1* and *orfA2* suggested that *npdR* may encode for a transcriptional regulator of the IclR family, and *orfA1* and *orfA2* may encode for two components of a signal transduction protein. The *npdR* gene was expressed in *E. coli*, the protein was purified and shown to bind to intergenic regions between *orfA1* and *orfB*, and between *npdH* and *npdI*. DNP, TNP, 2-chloro-4,6-dinitrophenol, and 2-methyl-4,6-dinitrophenol induced the expression of *npdI* and *npdC* by reducing the binding affinity of NpdR to the DNA-binding regions. Both intergenic regions were cloned upstream of a reporter gene (*xylE*), causing the expression of *xylE*. Hence, both intergenic regions contain promoters. Two direct repeats were identified immediately downstream of the two promoter regions. Gel retardation assays with one of the direct repeats between *orfA1* and *orfB* demonstrated that it was the binding site for NpdR. The sequences of the two direct repeats were 82 % identical, suggesting that the second direct repeat between *npdH* and *npdI* may be a second binding site for NpdR. This coincided with gel retardation assays, which showed that NpdR might bind to two sites in each intergenic region. A deletion mutant for *npdR* in *R. opacus* HL PM-1 was constructed, in which an internal part of *npdR* was deleted. The expression of *npdC* and *npdI* were induced by DNP in the wild-type strain, but were constitutive in the mutant. Hence, NpdR is a repressor involved in TNP degradation. *In vivo* deletion mutants for *orfA1* or *orfA2* were also constructed, in which the entire *orfA1* or a part of *orfA2* was deleted. If *orfA1* and *orfA2* encode for transcriptional regulators involved in TNP degradation, an effect on expression of the *npd* genes or on the growth with TNP would be expected in the mutants. However, there was no change in the expression of *npdC* or *npdI* in both mutant strains. Resting cells of the deletion mutants for *orfA1* or *orfA2* with TNP as a substrate did not show any difference in TNP conversion compared to the wild-type cells. Further growth rate of the mutants on TNP as nitrogen source was also similar to that of the wild-type strain. In order to eliminate the possibility of a second copy of *orfA1* or *orfA2* with

full activity in strain HL PM-1, the location of *npd* genes was determined. *npdC*, *npdI*, *npdR*, *orfA1* and *orfA2* were localised on the chromosomal DNA in strain HL PM-1. Hybridisation analysis of total DNA from strain HL PM-1 with *npdR*, *orfA1* or *orfA2* probes revealed that these genes are present as a single copy in the strain. Hence, *orfA1* and *orfA2* seem not to be involved in TNP degradation. To conclude, it was shown that NpdR is a repressor of TNP degradation, that two promoter regions are present in the *npd* gene cluster, and that *orfA1* and *orfA2* are not involved in metabolism of TNP as nitrogen source.

Zusammenfassung

Rhodococcus opacus HL PM-1 verwendet 2,4,6-Trinitrophenol (TNP) und 2,4-Dinitrophenol (DNP) als einzige Kohlenstoff-, Stickstoff- und Energiequelle. Die TNP abbauenden Enzyme werden von dem *npd*-Gencluster kodiert. Der TNP-Abbau beginnt mit zwei Hydrierungsreaktionen. Diese werden von der Hydridtransferase I (kodiert von *npdC*), der Hydridtransferase II (kodiert von *npdI*) und der NADPH-abhängigen F₄₂₀ Reduktase (kodiert von *npdG*) katalysiert.

In dieser Arbeit wurden drei offene Leserahmen *orfA1*, *orfA2* und *npdR* untersucht. Datenbankvergleiche der Aminosäuresequenzen deuteten darauf hin, dass *npdR* für einen Regulator der IclR-Familie kodiert und *orfA1* und *orfA2* wahrscheinlich für Signaltransduktionsproteine kodieren. Das *npdR* Gen wurde in *Escherichia coli* überexprimiert und das Protein aufgereinigt. Es wurde gezeigt, dass NpdR an die DNA in den intervenierenden Regionen zwischen *orfA1* und *orfB* und zwischen *npdH* und *npdI* bindet. DNP, TNP, 2-Chlor-4,6-dinitrophenol und 2-Methyl-4,6-dinitrophenol induzierten die Expression von *npdC* und *npdI* indem sie die Affinität von NpdR zu den oben genannten DNA Regionen herabsetzten. Beide DNA Bereiche wurden vor ein Reporter gen (*xylE*) kloniert und führten zur Expression von *xylE*. Demnach enthalten beide Bereiche Promotoren. Zwei sich wiederholende Sequenzen („direct repeats“) folgen unmittelbar auf die zwei Promotorbereiche. Gelretentionsanalysen mit einem der beiden „direct repeats“ zwischen *orfA1* und *orfB* zeigten, dass dieses die Bindungsstelle für NpdR ist. Die Wiederholungssequenzen waren zu 82% identisch, was darauf hindeutet, dass es sich bei dem zweiten Bereich ebenfalls um eine Bindungsstelle von NpdR handeln könnte. Es wurde durch Gelretentionsanalysen bestätigt, dass NpdR jeweils an zwei Stellen der beiden intervenierenden Regionen binden kann. Es wurde eine Deletionsmutante konstruiert, indem eine innere Teilsequenz von *npdR* in *R. opacus* HL PM-1 deletiert wurde. Im Wildtypstamm wurde die Expression von *npdC* und *npdI* durch DNP induziert, hingegen war die Expression in der Deletionsmutante konstitutiv. Folglich ist NpdR ein Repressor, der am TNP Abbau beteiligt ist. Es wurden auch Deletionsmutanten von *orfA1* und *orfA2* hergestellt. Dabei wurde der gesamte *orfA1* oder ein Teil von *orfA2* deletiert. Wenn *orfA1* und *orfA2* als Transkriptionsregulatoren am TNP Abbau beteiligt sind, dann sollte die Expression der *npd* Gene oder Wachstum auf TNP in den Mutanten beeinträchtigt sein. Keine der beiden Deletionsmutanten zeigte eine veränderte Expression von *npdC* oder *npdI*. Ruhezellen der

Deletionsmutanten mit TNP als Substrat unterschieden sich nicht im TNP Abbau von Wildtypzellen. Auch die Wachstumsraten der Mutanten auf TNP als Stickstoffquelle waren ähnlich zu denen des Wildtyps. Um die Möglichkeit einer weiteren aktiven Kopie von *orfA1* und *orfA2* im Stamm HL PM-1 auszuschließen, wurden die *npd* Gene lokalisiert. Es zeigte sich, dass *npdC*, *npdI*, *npdR*, *orfA1* und *orfA2* sich auf der chromosomalen DNA des Stamms HL PM-1 befinden. Hybridisierung von der gesamten DNA vom Stamm HL PM-1 mit Sonden gegen *npdR*, *orfA1* oder *orfA2* zeigten, dass diese Gene nur als einfache Kopie in diesem Stamm vorliegen. Folglich scheinen *orfA1* und *orfA2* nicht am TNP Abbau beteiligt zu sein. Zusammenfassend lässt sich sagen, dass NpdR ein Repressor für den TNP Abbau ist, dass zwei Promotorregionen im *npd* Gencluster vorhanden sind und, dass *orfA1* und *orfA2* nicht am Stoffwechsel von TNP als Stickstoffquelle beteiligt sind.

1. Introduction

1.1. DNP and TNP in the environment

2,4,6-trinitrophenol (TNP or picric acid) and 2,4-dinitrophenol (DNP) are nitroaromatic compounds not identified in the natural environment. They are synthesised for industrial purposes. TNP was formerly used in the textile industry for dyeing wool, silk and leather. It is the oldest nitro dye first found by Woulfe in 1771 (Elvers et al., 1991). TNP is used for the production of 2-amino-4,6-dinitrophenol (picramic acid), which is feedstock for the synthesis of azo dyes (Russ et al., 2000). In analytical chemistry, TNP is used as a test reagent to identify alkaloids, cardenolids and creatinine (Falbe et al., 1999).

TNP was produced intensively for use as an explosive during World War I. Nowadays, it is no longer employed as a high explosive (Elvers et al., 1991). However, due to its use for many years there are many places heavily contaminated with picric acid, especially the military sites where explosives were manufactured during the 20th century (Spain et al., 2000).

Dinitrophenols exhibit a wide range of biocidal activity and were therefore used as insecticides, herbicides, and fungicides. However, dinitrophenol insecticides are no longer used due to their toxicity to plants, insects, animals and humans (Elvers et al., 1991). Nevertheless, DNP is used for manufacturing of dyes still today (Russ et al., 2000).

Today, one of the main sources of dinitrophenols and picric acid in industrial effluents is the production of nitrobenzene from benzene. During the process, 0.1 % benzene consumed ends up as dinitrophenols and picric acid (Russ et al., 2000).

There are several mechanisms that contribute to the toxicity of picric acid. It causes irritations, burns and allergies upon external contact. When ingested, acute toxicity is due to acidosis. Chronic exposure may cause damage to red blood cells, liver, and kidneys (Wyman et al. 1992). DNP is much more toxic than TNP. Long-term exposure to DNP can cause damages of skin, eyes, bone marrow, and nervous system. The acute toxicity comes from the uncoupling effect of DNP. Being a weak acid, DNP can cross the membrane in its protonated form, acting as an H⁺ carrier, dissipating the electrochemical gradient across the cell membrane and thus uncoupling the oxidative phosphorylation pathway without blocking oxygen consumption (Russ et al., 2000).

The stability, persistence and toxicity that make DNP and TNP valuable to industry render them hazardous when released into the environment. The combination of the electron-withdrawing character of nitro groups and the stability of the aromatic ring makes them extremely stable and resistant to oxidative attack. Due to their toxicity described above and due to their recalcitrance, it is necessary to establish a suitable remediation strategy for removing them from polluted water and contaminated sites. A cost-effective and environmental sustainable strategy is clean up of nitrophenols by microorganisms.

1.2. DNP and TNP degradation by bacteria

Microbial degradation of nitroaromatic compounds has been studied more intensively during the past 10 years because of the growing awareness of environmental contamination by pesticides, synthetic intermediates, and explosives.

Photochemical degradation of different nitrophenols, including DNP and TNP, was described recently (Prousek et al., 1996). *Rhodobacter capsulatus* transforms DNP to 2-amino-4-nitrophenol in a light dependent reaction under anaerobic conditions. Further, 2-amino-4-nitrophenol can be degraded only in the presence of light, oxygen, and additional carbon and nitrogen sources (Blasco et al., 1992; Witte et al., 1998).

As mentioned before, the oxidative attack on the aromatic ring of TNP or DNP is not possible. Hence, TNP and DNP undergo ring reduction by enzymatic hydride transfer. Some bacteria of the genera *Rhodococcus* and *Nocardioides* grow aerobically on TNP and/or DNP as a sole nitrogen and/or carbon and energy source (Lenke et al., 1992a; 1992b; Rajan et al., 1996; Blasco et al., 1999; Behrend et al., 1999; Rieger et al., 1999). Recently, the degradation pathways of TNP and DNP as well as the metabolic enzymes have been identified and characterised intensively in *Rhodococcus opacus* HL PM-1 and *Nocardioides simplex* FJ2-1A. Both strains are able to grow on DNP and TNP as a sole nitrogen, carbon and energy source (Rajan et al., 1996; Rieger et al., 1999).

The first step of TNP reduction in both strains is a hydrogenation reaction, forming the hydride Meisenheimer complex of TNP (H⁻-TNP) (Lenke et al., 1992b; Rieger et al., 1999; Ebert, 2001a). This reaction is catalysed by the hydride transferase II (HTII) which transfers a hydride ion from reduced F₄₂₀ to the aromatic ring of TNP, generating H⁻-TNP (Ebert et al. 1999; Heiss et al., 2002; 2003) (Fig.1).

The second step of TNP reduction is also a hydrogenation reaction that converts H-TNP to the dihydride Meisenheimer complex (2H-TNP) (Lenke et al., 1992b). In *N. simplex* FJ2-1A, the HTII also catalyses this reaction (Ebert et al., 2001a), whereas the HTII of *R. opacus* HL PM-1 has insignificant activity for H-TNP. Instead, a second hydride transferase (HTI) subsequently transfers a hydride ion to H-TNP, to produce the 2H-TNP (Heiss et al., 2002). All hydrogenation reactions require the activity of an NADPH-dependent F₄₂₀ reductase (NDFR), for shuttling the hydride ions from NADPH to F₄₂₀ (Ebert et al., 1999; Russ et al., 2000; Heiss et al., 2002; 2003) (Fig.1). These enzymes are encoded by the *npd* genes (Fig.2). The *npdI* encodes for HTII, the *npdG* encodes the NDFR, and the *npdC* encodes the HTI (Heiss et al., 2002).

2H-TNP is not a dead-end product as previously believed (Lenke et al., 1992b), but is further degraded productively. Under alkaline condition (pH 8), 2H-TNP exists as a double charge anion, the so-called *aci*-nitro form. This structure is converted to the tautomeric nitro form spontaneously by a proton shift tautomerisation. Tautomerisation between the *aci*-nitro and the nitro form is catalysed by a tautomerase that encoded by *npdH*. The tautomerase catalyses the conversion of the nitro form to the *aci*-nitro form, which is the substrate for the next enzyme in the pathway (Fig.1) (Hofmann, 2003). Recently, the nitrite-eliminating enzyme was purified from *N. simplex* FJ2-1A. The enzyme releases nitrite only from the *aci*-nitro form of 2H-TNP (not from the nitro form), forming hydride Meisenheimer complex of DNP (H-DNP). This finding supports the function of *NpdH* in the TNP degradation (Fig.1) (Hofmann, 2003).

H-DNP is where the TNP and DNP pathways converge. DNP is also converted to the H-DNP in a hydrogenation reaction catalysed by the HTII and requires the activity of NDFR (Hofmann, 2003). The H-DNP is further hydrogenated to the dihydride complex of DNP (2H-DNP). This reaction is catalysed by the HTI from strain HL PM-1 and also requires NDFR, coenzyme F₄₂₀ and NADPH. Under physiological condition, 2H-DNP is subsequently protonated, producing 2,4-dinitrocyclohexanone (2,4-DNCH). A hydrolase (purified from *N. simplex* FJ2-1A) cleaves 2,4-DNCH, generating 4,6-dinitrohexanoate (4,6-DHN) (Fig.1) (Hofmann, 2003). The sequence of the N-terminal amino acid of the hydrolase reveals 78 % sequence identities to the product of *orfF* in *R. opacus* HL PM-1, suggesting that *orfF* may encode for a related hydrolase. Hence, *orfF* has been named *npdF* (Fig.2).

Although, the subsequent conversion of 4,6-DHN is still unknown, experiments using crude extracts of *R. opacus* HL PM-1 suggests that 4,6-DHN is converted to aliphatic products undetectable by HPLC (Hofmann, 2003). It is possible that the two nitro groups are cleaved from 4,6-DHN, with the resulting carboxylic acid being the substrates for the tricarboxylic acid cycle.

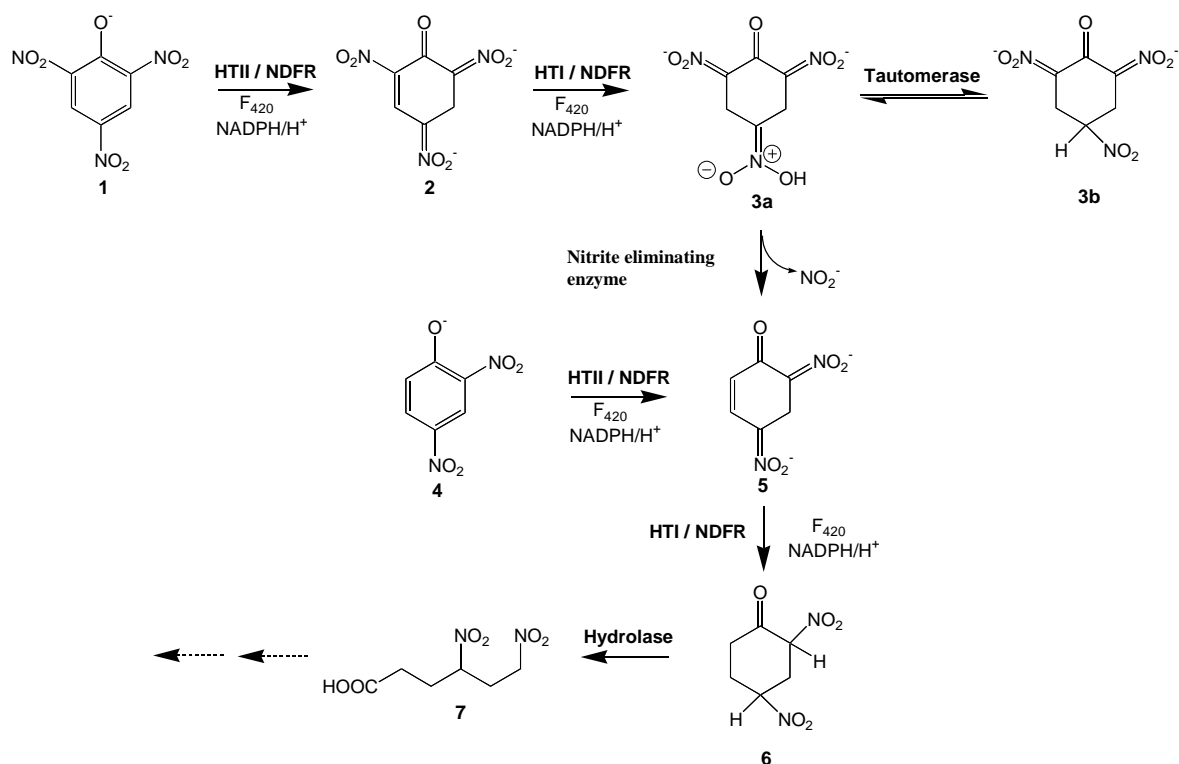

Fig.1. Upper converging degradation pathway of TNP and DNP. 1. TNP; 2. H-TNP; 3a. *aci*-nitro form of 2H-TNP; 3b. nitro form of 2H-TNP; 4. DNP; 5. H⁻-DNP; 6. 2,4-DNCH; 7. 4,6-DNH; HTII, hydride transferase II (AAK38104); NDFR, NADPH-dependent F_{420} reductase (AAK38102); HTI, hydride transferase I (AAK38097); tautomerase: (AAK38103) The numbers in brackets are the accession numbers.

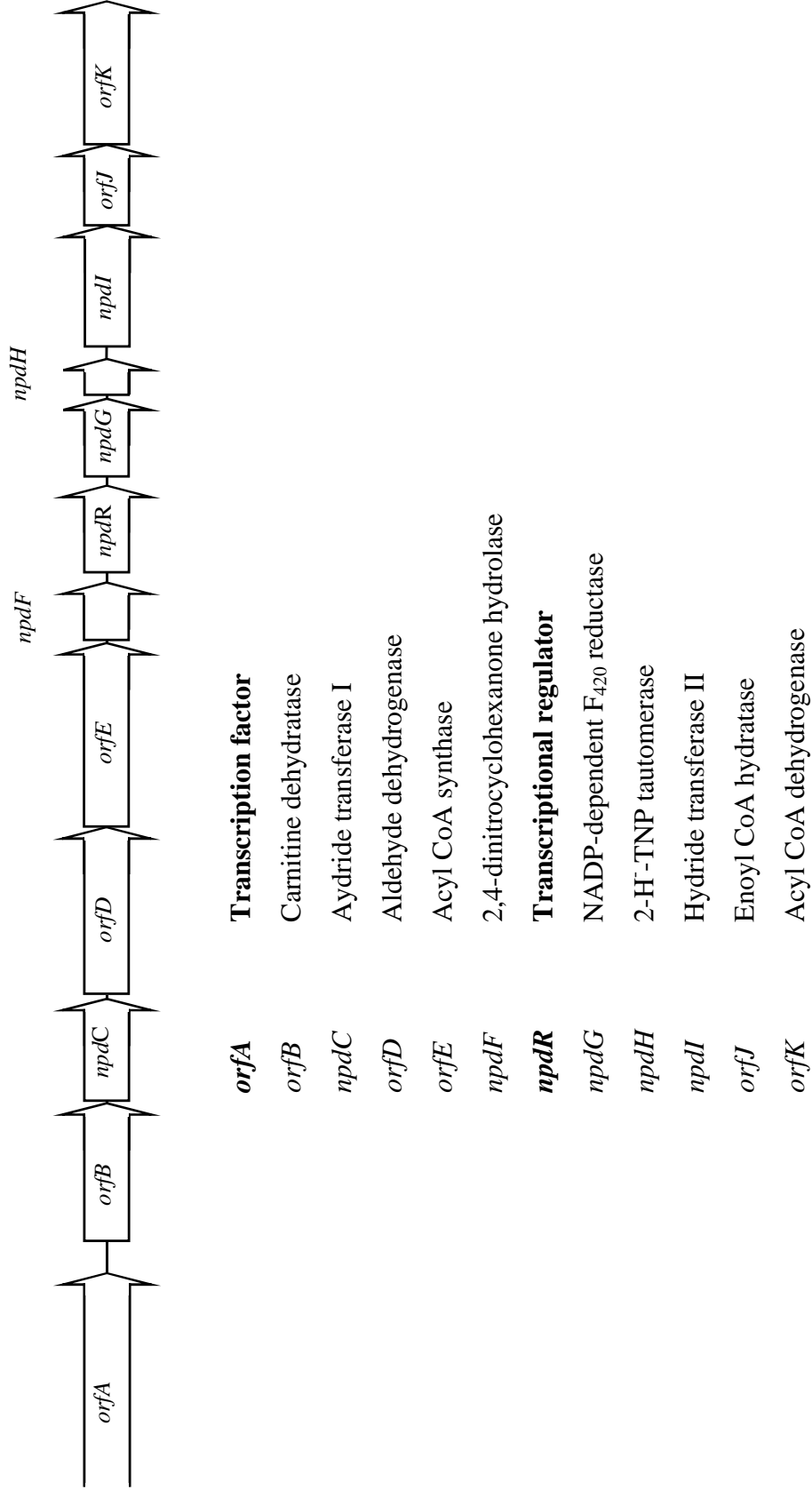

Fig.2. The picric acid degradation gene cluster of *R. opacus* HL PM-1. *orf* are open reading frames with predicted function based on the sequence similarities with protein sequences in the database. *npd* genes were characterised and their functions identified. Genes in bold were characterised in this work.

1.3. Gene regulation of nitroarene degradation

Despite the rise in number of studies on biodegradation of nitroaromatic compounds, only few investigations have been reported on the molecular biology of degradation pathways such as those of nitrobenzene, 2- and 4-nitrotoluene, 2,4-dinitrotoluene, and *p*-nitrophenol (Suen et al., 1993; Parales et al., 1996; Zylstra et al., 2000; Park et al., 2001; Hughes et al., 2001; Lessner et al., 2003). Study on regulatory mechanisms of those degradation genes is now at its very beginning, and very little has been reported on DNP or TNP degradation.

Not much on regulation of nitrobenzene and nitrotoluene degradation has been reported, and only a few bacteria have been studied. *Comamonas* sp. strain JS765 is able to utilise nitrobenzene as the sole source of carbon and nitrogen. *Acidovorax* sp. strain JS42 utilises 2-nitrotoluene as a nitrogen and carbon source. Strain JS765 and JS42 possess identical LysR-type regulators, NbzR and NtdR respectively. NtdR is an activator required for the induction of 2-nitrotoluene dioxygenase by nitrobenzene, 2-, 3-, and 4-nitrotoluene, 2,4- and 2,6-dinitrotoluene and aminodinitrotoluene, as well as salicylate and anthranilate. The expression of the nitrobenzene dioxygenase in JS765 is also inducible by the above mentioned compounds. This finding, together with the similarity in the nucleotide sequence of *nbzR* and *ntdR*, suggests that the regulation mechanism of 2-nitrotoluene dioxygenase in strain JS42 is similar to that of nitrobenzene dioxygenase in strain JS765. (Lessner et al., 2003). Hence, NbzR may also be an activator.

Another report describes NbzR from *P. putida* HS12 as a negative regulator also responding to nitrobenzene as an effector. *P. putida* HS12 grows with nitrobenzene as sole source of carbon and nitrogen through a partial reductive pathway where nitrobenzene is converted to 2-aminophenol. In this case NbzR is a repressor of the 2-aminophenol operon (Park et al., 2001). However, in both strains *Comamonas* sp. strain JS765 and *P. putida* HS12, it is still unclear whether NbzR responds directly to nitrobenzene or not.

Burkholderia sp. strain DNT and *B. cepacia* strain R34 oxidise 2,4-dinitrotoluene by a 2,4-dinitrotoluene dioxygenase. The deduced amino acid sequence of the regulatory gene, *dntR* from strain DNT is 97 % identical to that of the *ntdR* (from strain JS42). In addition, the *nbz* and *ntd* promoter regions are identical, and there are very few differences in the sequence of the *nbz/ntd* promoter region from that of the *dnt* gene cluster. Moreover, the sequence of the regulators NtdR, NbzR, and DntR are 61 %, 61 %, and 62 % identical to that of the activator

NahR of naphthalene-degrading genes from *P. putida* G7. The consensus binding sequence for NahR was identified upstream of *nbz*, *ntd*, *dnt* genes. These findings suggest that those nitroarene-dioxygenase gene clusters may be controlled by a similar mechanism. This is in line with the fact that all of the nitroarene dioxygenases identified to date fall within the naphthalene dioxygenase family of Rieske nonheme iron oxygenase (Gibson et al., 2000; Parales et al., 2000), and are similar to the naphthalene dioxygenases from *Rastonia* sp. U2 and *P. putida* G7 (Parales et al., 2000).

Only few studies have been carried out in determining the molecular basis of nitrophenols degradation thus far. The genes for *p*-nitrophenol degradation from *Pseudomonas* sp. strain ENV2030 are arranged in at least three operons with two regulatory genes *pnpR* and *pnpS* which belong to LysR-type regulators. PnpR and PnpS are shown to regulate *p*-nitrophenol degradation positively. LysR DNA binding motifs are found in the sequence of *pnp* genes and upstream of *pnpR* and *pnpS*. This suggests that PnpR positively regulates *pnpA* and *pnpB*, while PnpS positively regulates the *pnpDEC* operon and the two regulators may also regulate their own synthesis (Zylstra et al., 2000).

So far, there are a lot of speculations about the function and regulation mechanism of nitroarene regulators. Biochemical studies remain to be done in order to support the role of the described regulators in nitroarene degradation. The regulatory mechanisms of dinitrophenol and trinitrophenol degradation are almost completely lacking. The work described here is the first insight into gene regulation of dinitrophenol and trinitrophenol metabolism.

1.4. Significance and aim of this work

As described in section 1.2, some bacteria are capable of utilising TNP and DNP as a nitrogen, carbon and energy source. However, often degradation is incomplete, leading to accumulation of dead-end products. Understanding the regulation of TNP degradation may help to clarify the problem and it is also an important step towards developing a more effective biological system for treatment of contaminated sites and effluents.

R. opacus HL PM-1 was chosen for studying regulation of TNP degradation for the following reasons:

Strain HL PM-1 is a typical representative of Gram positive bacteria, which degrade DNP and TNP by an initial reductive mechanism. On the other hand, the biochemical pathway of TNP/DNP degradation is best understood in this strain. The TNP degradation gene cluster of HL PM-1 was shown to contain two apparent transcriptional regulators *npdR* and *orfA* (see Fig.2). Such genes are expected since the *npd* genes are inducible by DNP (Walters et al., 2001).

In order to understand more on regulation of TNP degradation in *R. opacus* HL PM-1, we aimed to focus on determining whether *npdR* and *orfA* are involved in TNP/DNP degradation or not. To achieve this we planned to identify their function, and the mechanisms by which they regulate TNP/DNP degradation. Further, the regulatory regions and the alternative inducers that affect the degradative potential of the bacteria also needed to be determined. Comparing the function of *npdR*, *orfA* and the inducibility of the TNP/DNP degradation pathway in different strains will help in understanding the diversity of the regulation mechanism of TNP degradation in nature.

These studies would contribute in filling the gap of knowledge in regulation of nitroaromatic compounds. They are also of use to the *Rhodococcus* scientific community, since more insights are gained on genetic manipulation of *Rhodococcus*.

2. Materials and methods

2.1. Bacteria and plasmids

The bacterial strains used in this study are listed in Table 1. The plasmids used are listed in Table 2.

Table 1. Bacteria used

Bacterial strain	Relevant genotype and / or phenotype	Reference or source
<i>Escherichia coli</i> DH5 α	F ⁻ Φ 80dlacZ Δ M15 Δ (lacZYA-argF)U169 <i>deoR hsdR17</i> (r ⁻ , m ⁺) <i>supE44 recA1 endA1</i> <i>thi-1 gyrA96 λ-relA1</i>	Gibco Life Technologies, Eggenstein, BLR
<i>Escherichia coli</i> BL21 (DE3)	F ⁻ <i>ompT hsdS</i> (r _B ⁻ , m _B ⁻) <i>gal</i> (λ cIts857 <i>ind1</i> <i>Sam7 nin5 lacUV5-T7 gene 1</i>)	Novagen, Madison, USA
<i>Escherichia coli</i> S17-1	<i>thi pro hsdR⁻ hsdM⁺ recA res⁻ mod⁺</i> RP4-2- (Tc::Mu)-(Km::Tn7)	Simon et al. (1983)
<i>Rhodococcus</i> <i>rhodochrous</i> ATCC 12674	Inability to grow on TNP and DNP as sole nitrogen source	Dabbs and Sole (1988)
<i>Rhodococcus opacus</i> HLPM-1	Ability to grow on TNP and DNP as sole nitrogen source	Lenke and Knackmuss (1992)
<i>Rhodococcus opacus</i> ND1	Derived from <i>Rhodococcus opacus</i> HLPM-1. Deletion in <i>npdR</i>	This work
<i>Rhodococcus opacus</i> ND2	Derived from <i>Rhodococcus opacus</i> HLPM-1. Deletion in <i>orfA2</i>	This work
<i>Rhodococcus opacus</i> ND3	Derived from <i>Rhodococcus opacus</i> HLPM-1. Deletion of <i>orfA1</i>	This work

Table 2. Plasmids used

Plasmid	Relevant genotype and / or phenotype	Reference or source
pAC28	Km ^r ; phage T7 promoter; ColE1 ori; C terminal tag containing six polyhistidine	Kholod and Mustelin (2001)
pBluescript II SK (+)	Amp ^r ; P _{lac} ; ColE1 ori	Gibco Life Technologies Eggenstein, BRL
pET11a	Amp ^r ; phage T7 <i>lac</i> promoter; ColE1 ori	Novagen, Madison, USA
pJOE814.2	Amp ^r ; ColE1 ori; <i>xylE</i> reporter gene	J. Altenbuchner - Unpublished
pK4	Km ^r ; P _{lac} ; ColE1 ori; <i>Rhodococcus</i> ori	Hashimoto et al. (1992)
pK18 <i>mobsacB</i>	Contain oriT of pRP4; Suc ^s	Schäfer et al. (1994)
pNGA1	<i>npdR</i> inserted into the <i>NdeI</i> and <i>BamHI</i> sites of pET11a	This work
pNGA5	<i>npdR</i> inserted into the <i>NdeI</i> and <i>BamHI</i> sites of pAC28	This work
pNGA6	IGRI' inserted into the <i>EcoRI</i> and <i>BamHI</i> sites of pJOE814.2	This work
pNGA7	IGRI' and <i>xylE</i> inserted into the <i>XbaI</i> site of pK4	This work
pNGA8	<i>xylE</i> inserted into the <i>XbaI</i> site of pK4	This work
pNGA9	IGRIV' inserted into the <i>EcoRI</i> and <i>KpnI</i> sites of pNGA8	This work
pNGA20	2.2 kb <i>EcoRI</i> - <i>BamHI</i> fragment (containing 210 bp deletion in <i>npdR</i>) ligated into <i>EcoRI</i> and <i>BamHI</i> sites of pK18 <i>mobsacB</i>	This work

pNGA27	Intergenic region between <i>npdF</i> - <i>npdR</i> inserted into the <i>EcoRI</i> and <i>KpnI</i> sites of pNGA8	This work
pNGA29	2.2 kb fragment (containing 570 bp deletion in <i>orfA1</i>) ligated into <i>SmaI</i> site of pK18 <i>mobsacB</i>	This work
pNGA34	2.5 kb <i>EcoRI</i> - <i>SacI</i> fragment (containing the 5' end unknown sequence of <i>orfA2</i>) ligated into <i>EcoRI</i> and <i>SacI</i> sites of pBluescript II SK(+)	This work
pNGA37	2.2 kb fragment (containing 1182 bp deletion in <i>orfA2</i>) ligated into <i>SmaI</i> site of pK18 <i>mobsacB</i> .	This work
pNGA38	<i>orfA1</i> gene inserted into <i>NdeI</i> and <i>BamHI</i> sites of pAC28.	This work

IGRI': 157 bp, 3' end region of the intergenic region between *orfA1-orfB*; IGRIV': intergenic region between *npdH-npdI* plus the 3' end of *npdH*.

2.2. Media, buffers and solutions

2.2.1. Media

Minimal medium (Dorn et al. 1974)	Phosphate buffer (pH 7.5)	
	Na ₂ HPO ₄ x 2 H ₂ O	7.12 g
	KH ₂ PO ₄	1.36 g
	CaCl ₂ x 2 H ₂ O	0.45 mM
	Sodium acetate	40 mM
	Salts solution without nitrogen source (100 x)	
	CaCl ₂ x 2 H ₂ O	0.5 g
	MgSO ₄ x 7 H ₂ O	10 g
	Fe(III) – citrate x H ₂ O	0.2 g

SL6 solution	10 ml
Salt solution with nitrogen source (100 x)	
MgSO ₄ x 7 H ₂ O	4 g
Fe(III)NH ₄ – citrate x H ₂ O	0.2 g
(NH ₄) ₂ SO ₄ x 4 H ₂ O	20 g
After autoclaving add	
SL6 solution	10 ml
Ca(NO ₃) ₂ x 4 H ₂ O	0.01 g
SL6 solution (Pfennig et al. 1966)	
ZnCl ₂	100 mg
MnCl ₂ x 2 H ₂ O	100 mg
H ₃ BO ₃	62 mg
CoCl ₂ x 6 H ₂ O	190 mg
CuCl ₂ x 2 H ₂ O	17 mg
NiCl ₂ x 6 H ₂ O	24 mg
NaMoO ₄ x 2 H ₂ O	36 mg
HCl (25 %)	1.3 ml
H ₂ O	1000 ml

Phosphate buffer, the salts solution and SL6 solution should be separately autoclaved, then mixed together.

Complex medium

LB (pH 7.5) (Luria et al. 1960)	Tryptone	10 g
	Yeast extract	5 g
	NaCl	5 g
	H ₂ O	to 1000 ml
SOB (Dower et al. 1988)	Tryptone	20 g
	Yeast extract	5 g

	NaCl	0.6 g
	KCl	0.18 g
	H ₂ O	to 995 ml
	After autoclaving add	
	MgCl ₂ (2 M)	5 ml
SOC	SOB plus	
(Dower et al. 1988)	Glucose (1 M)	20 ml

Table 3. Antibiotics and other medium components

Antibiotic	Stock solution (mg/ml)	Working concentration (µg/ml)
Ampicillin	100 in 50 % Ethanol	100
Kanamycin	30 or 80 in H ₂ O	30 (for recombinant <i>E. coli</i>) 80 (for recombinant <i>Rhodococcus</i>)
Nalidixic acid	40 in H ₂ O	40
IPTG	23.8 in H ₂ O	238
X-Gal	20 in DMF	80

2.2.2. Buffers and solutions

Buffer H1 (pH 7.5)	Maleic acid	0.1 M
	NaCl	0.15 M
	Adjust pH with solid NaOH	
Buffer H2	blocking reagent	1 % (w/v)
	in buffer H1	
Buffer H3 (pH 9.5)	Tris	0.1 M
	NaCl	0.1 M

	MgCl ₂	50 mM
	Adjust pH with HCl	
Denaturation solution	NaOH	0.5 M
	NaCl	1.5 M
DNA loading buffer	Xylencyanol	0.25 % (w/v)
	Bromphenolblue	0.25 % (w/v)
	Glycerol	50 % (v/v)
	EDTA pH 8.0	0.5 M
Destaining solution	Methanol	40 % (v/v)
	Acetic acid	10 % (v/v)
EC buffer	NaCl	1 M
	EDTA	100 mM
	Tris/HCl (pH 7.6)	6 mM
	Brij 58	0.5 % (w/v)
	Deoxycholate	0.2 % (w/v)
	N-lauroylsarcosine	0.5 % (w/v)
ES buffer	EDTA (pH 8)	0.5 M
	N-lauroylsarcosine	1 % (w/v)
	Proteinase K	0.1 % (w/v)
GMSA buffer	Tris/HCl pH 7.5 (1 M)	250 µl
(5 x)	KCl (2 M)	625 µl
	Glycerol (87 %)	1250 µl
	MnCl ₂ (1 M)	5 µl
	Fish sperm DNA (10 mg/ml)	25 µl

	BSA (10 mg/ml)	125 μ l
	H ₂ O	2730 μ l
His-tag loading buffer (pH 8.0)	Na ₂ HPO ₄	50 mM
	NaCl	300 mM
	Imidazole	5 mM
His-tag washing buffer 1 (pH 8.0)	Na ₂ HPO ₄	50 mM
	NaCl	300 mM
	Imidazole	25 mM
His-tag washing buffer 2 (pH 8.0)	Na ₂ HPO ₄	50 mM
	NaCl	300 mM
	Imidazole	50 mM
His-tag elution buffer (pH 8.0)	Na ₂ HPO ₄	50 mM
	NaCl	300 mM
	Imidazole	150 mM
Hybridisation solution (Southern)	SSC	5 x
	Blocking reagent	1 % (w/v)
	Na-Lauroylsarcosine	0.1 % (w/v)
	SDS	0.02 % (w/v)
Lysis buffer (pH 8.0)	Tris/HCl	50 mM
	EDTA	25 mM
	Saccharose	10 % (w/v)
	Lysozyme	10 mg/ml

MOPS running buffer (pH 7.0, 10 x)	MOPS pH 7.0	0.3 M
	Sodium acetate	50 mM
	EDTA pH 8.0	20 mM
	Adjust pH with NaOH	
Native-PAGE-Running buffer (pH 8.3, 10 x)	Tris/HCl pH 8.3	0.4 M
	Acetic acid	1.14 % (v/v)
	EDTA	10 mM
NBT	Nitroblue tetrazolium in 70 % DMF	75 mg/ml
Neutralisation solution	NaCl	1.5 M
	Tris/HCl pH 7.4	0.5 M
RNA-Loading buffer (5 x)	Formamide	250 µl
	Formaldehyde (37 %)	83 µl
	MOPS (10 x)	50 µl
	Glycerol	50 µl
	Bromphenolblue (2.5 % w/v)	10 µl
	DEPC treated H ₂ O	57 µl
Salt solution	NaCl	0.9 % (w/v)
	Triton X-100	0.01 % (v/v)
SDS- PAGE-Loading buffer (5 x)	Tris/HCl pH 6.8	250 mM
	EDTA	10 mM
	SDS	5 % (w/v)
	β-Mercaptoethanol	5 % (v/v)
	Glycerol	50 % (v/v)
	Bromphenolblue	0.005 % (w/v)

SDS-PAGE-Running buffer (1 x)	Tris	25 mM
	Glycine	250 mM
	SDS	0.1 % (w/v)
Staining solution	Methanol	40 % (v/v)
	Acetic acid	10 % (v/v)
	Coomassie Blue R	0.25 % (w/v)
SSC (pH 7.0) (20 x)	NaCl	3 M
	Tri-sodium citrate	0.3 M
	Adjust pH with HCl	
TAE buffer (50 x)	Tris	2 M
	Acetic acid	5.7 % (v/v)
	EDTA pH 8.0	0.1 M
TBE buffer	Tris (pH 8)	45 mM
	Boric acid	45 mM
	EDTA	1 mM
TE buffer (10:0.1)	Tris/HCl pH 8.0	10 mM
	EDTA	0.1 mM
TE buffer (10:1)	Tris/HCl pH 8.0	10 mM
	EDTA	1 mM
Transformation buffer	HEPES	10 mM
	CaCl ₂	15 mM
	KCl	250 mM
	pH with KOH/HCl pH 6.7	
	After filter sterilisation add MnCl ₂	55 mM

X-Phosphate (Southern)	5-bromo-4-chloro-3-indolyl phosphate, toluidinium in DMF	5 mg/ml
Washing buffer (Southern)	Buffer H1 plus Tween-20	0.3 % (v/v)

2.3. Strain storage and culture condition

2.3.1. Strain storage

For short-term storage, the bacterial cultures were kept at 4 °C for two months. For long-term storage, an overnight culture was harvested and resuspended in fresh liquid medium supplemented with 50 % (v/v) glycerol and stored at -70 °C.

2.3.2. Culture condition

The *Escherichia coli* strains were cultured at 37 °C, 150 rpm (RFI-125, Infors AG, Bottmingen, Switzerland) in LB medium. Ampicillin or kanamycin was added to maintain the plasmids. The bacterial growth was controlled by measuring the optical density at 600 nm (OD_{600 nm}). For gene expression, an overnight culture of *E. coli* was subcultured in a larger volume with 1 % inoculum and then incubated at 37 °C. As the OD_{600 nm} reached 0.4-0.5, the cells were induced with 1 mM IPTG for 4 h at 30 °C, 100 rpm (RC-406, Infors AG, Bottmingen, Switzerland).

The *Rhodococcus* strains were cultured at 30 °C, 100 rpm (RC-406, Infors AG, Bottmingen, Switzerland) in LB or minimal medium with (NH₄)₂SO₄ or nitrophenol compounds as nitrogen source. For induction, a 24 h-preculture was subcultured in a larger volume with 1 % inoculum. When OD_{600 nm} reached 0.4-0.5, 0.5 mM nitrophenol was added for 3 h. Plasmids in *Rhodococcus* were selected for on kanamycin. Sensitivity to sucrose was tested on LB agar plate supplemented with 10 % (w/v) sucrose.

2.3.3. Resting cells

The strains were precultured in minimal medium with $(\text{NH}_4)_2\text{SO}_4$ as nitrogen source for 24 h at 30 °C, 100 rpm (RC-406, Infors AG, Bottmingen, Switzerland) then subcultured in a 200 ml of the same medium to $\text{OD}_{600\text{nm}} = 1.2-1.5$. The culture was induced with 0.5 mM inducer for 3 h or without inducer. The cells were harvested by centrifuging at 5000 rpm for 10 min (Sigma 3K-1, Deisenhofen) and washed twice with 50 mM $\text{KH}_2\text{PO}_4/\text{K}_2\text{HPO}_4$ buffer, pH 7.5. The cells were resuspended in the same buffer with an $\text{OD}_{600\text{nm}} = 1.5-2.0$. The cell suspensions were exposed to TNP or DNP at 30 °C and incubated on a shaker, 150 rpm (Model G76, New Brunswick Scientific, Edison, USA). The disappearance of the substrates and the formation of new metabolites were detected by HPLC, by taking samples at relevant time intervals. The samples were centrifuged at 14 000 rpm for 5 min (Eppendorf 5417C, Hamburg). The supernatants were analysed by HPLC.

2.4. Molecular genetic methods

2.4.1. Isolation of genomic DNA

For preparation of genomic DNA from *Rhodococcus*, the strain was cultured in 5 ml LB medium overnight at 30 °C. The cells were then centrifuged at 5000 rpm for 10 min (Sigma 3K-1, Deisenhofen) and washed with 50 mM Tris/HCl pH 8.0. The pellet was resuspended in 3 ml lysis buffer and the suspension was incubated overnight at 37 °C. The cells were harvested by centrifuging. The supernatant was removed. The pellet was resuspended in 5 ml of TE buffer supplemented with 100 µg/ml proteinase K and 300 µl of SDS 10 % (w/v). The suspension was further incubated for 2-4 hours at 37 °C until it became clear. The lysate was extracted twice with 5 ml of phenol, twice with 5 ml phenol/chloroform/isoamylalcohol (25:24:1) and once with 5 ml of chloroform plus isoamylalcohol (24:1). The DNA was then precipitated using 0.7 volume of isopropanol with 0.1 volume of 3 M Na-acetate, pH 5.4. The DNA was collected by centrifuging at 14 000 rpm for 10 min (Eppendorf 5417C, Hamburg). The DNA was washed once in 70 % ethanol (v/v) and 90 % ethanol (v/v). The pellet was air dried, resuspended in TE buffer (10:0.1) and stored at 4 °C.

2.4.2. Isolation of plasmid DNA

Plasmid isolation was accomplished using Micro Plasmid Prep kit (Amersham Biosciences, Buckinghamshire, UK). 1-1.5 ml of an overnight culture was centrifuged in a microcentrifuge (Eppendorf 5417C, Hamburg) at full speed for 1 min to pellet the cells. The supernatant was removed by aspiration. The pellet was resuspended completely in 150 μ l of Solution I with vigorous vortexing. 150 μ l of Solution II was added and mixed by inverting the tube 10-15 times. The bacterial suspension should begin to clear as cell lysis occurs. 300 μ l of Solution III was added and mixed by inverting the tube until the precipitate was evenly dispersed. The sample was centrifuged at full speed for 5 min at room temperature to pellet the cell debris. The supernatant was transferred to a prepared GFX column, incubated for 1 min and centrifuged at full speed for 30 s. The flow-through was discarded. 400 μ l of Wash buffer was added to the column. The tube was then centrifuged at full speed for 60 s to remove the buffer and dry the matrix. The column was transferred to a fresh tube and 50-100 μ l of TE (10:0.1) was added directly on the top of the matrix. The sample was incubated for 1 min then centrifuged at full speed for 1 min to recover the purified plasmid. The DNA was stored at -20 °C.

2.4.3. Isolation of RNA

For isolation of RNA from *Rhodococcus*, the strain was cultured in 10 ml of minimal medium with $(\text{NH}_4)_2\text{SO}_4$ as nitrogen source at 30 °C until the $\text{OD}_{600\text{nm}} = 0.4-0.5$. Then 0.5 mM of nitrophenol compound was added to the culture and induced for 2 h. 20 ml of RNAprotect bacteria reagent (Qiagen, Hilden) was mixed with the culture and incubated at room temperature for 5 min. The cells were then centrifuged at 5000 rpm, 4 °C for 10 min to pellet the cells (Sigma 3K-1, Deisenhofen). The RNA was obtained by using RNeasy Mini Kit (Qiagen, Hilden) with the slightly modified protocol of the supplier. The cells were resuspended in 100 μ l of TE buffer supplemented with 2 mg lysozyme and 15 % (w/v) sucrose and incubated for 10 min. The suspension was vortexed with glass beads (0.25 mm) for 20 min. 350 μ l of RLT buffer was added to the sample and mixed thoroughly by vortexing vigorously. The sample was centrifuged in a microcentrifuge at maximum speed for 2 min (Eppendorf 5417C, Hamburg). Only the supernatant was transferred to a fresh tube. The lysate was mixed thoroughly with 250 μ l of ethanol by pipetting. The sample was applied to a RNeasy mini column placed in 2 ml collection tube. The tube was closed and centrifuged at

10 000 rpm for 15 s. The flow-through was discarded. 350 µl of RW1 buffer was added into the column. Repeat the centrifuging and discarding. The column was further treated with DNase I, 30 Kunitz units in 80 µl of RDD buffer (RNase-Free DNase Set, Qiagen, Hilden) for 15 min at room temperature. Another 350 µl of RW1 buffer was added to the column. The sample was centrifuged again at the same condition. The spin column was placed in a new 2 ml collection tube. 500 µl of RPE buffer was pipetted into the column. The sample was then centrifuged. Repeat washing the column with 500 µl of RPE buffer and centrifuge at full speed for 2 min to dry the silica-gel membrane. The column was transferred to a new 1.5 ml collection tube. The RNA was eluted by adding 30-50 µl of RNase free H₂O directly on the silica-gel membrane and centrifuging at 10 000 rpm for 1 min. The RNA was stored at -70 °C.

2.4.4. Determination of DNA/RNA concentration

The DNA/RNA concentration was determined by spectrophotometrically measuring its absorbance at 260 nm in 1 ml quartz cuvette. Absorbance reading at 260 nm should fall between 0.15 and 1.0 to be accurate. An A_{260} of 1 (with 1 cm detection path) corresponds to 50 µg DNA (double strands) or 40 µg RNA per ml water. Water was used as diluent.

Concentration of DNA/RNA (µg/ml) = 50 or 40 µg/ml $\times A_{260} \times$ dilution factor

The ratio of the reading at 260 nm and 280 nm (A_{260}/A_{280}) provides an estimate of the purity of the DNA/RNA with respect to contaminants that absorb UV, such as protein. However, this ratio is influenced by pH. For accurate values, 10 mM Tris/HCl pH 8.5 was used to dilute DNA/RNA. If the DNA/RNA has the ratio A_{260}/A_{280} of 1.8-2.0, it is considered pure enough.

2.4.5. Electrophoresis of nucleic acids

2.4.5.1. Agarose gel electrophoresis (Sharp et al. 1973)

Agarose gel electrophoresis was used to check the purity, determine the size, separate DNA fragments and recover the target DNA from a restriction digestion or a PCR reaction. The DNA was applied to a 0.7 -1.5 % (w/v) agarose gel. The agarose was melted by boiling in 1 x TAE buffer then cooled down to 55 °C. The melted agarose was supplemented with 0.5 µg/ml ethidiumbromide and cast. 10 x loading buffer was diluted with the DNA solution.

Electrophoresis was carried out in 1 x TAE buffer at 10 V/cm of gel using a Bio-Rad system (Bio-Rad, Hercules California, USA). Following electrophoresis, the DNA was visualised by exposing the gel to an UV transilluminator (302 nm) and documented by a video (IDA system, Raytest, Straubenhardt). λ -DNA digested with *EcoRI* and *HindIII*, GeneRuler 1 kb DNA Ladder, GeneRuler DNA Ladder Mix or GeneRuler 100 bp DNA Ladder (MBI Fermentas, Leon-Rot) were used as standards.

2.4.5.2. Polyacrylamide gel electrophoresis

For gel mobility shift assay, the DNA and DNA-Protein complexes were separated in a native polyacrylamide gel with a vertical electrophoresis system from Bio-Rad (Bio-Rad, Hercules California, USA). The acrylamide concentration ranged from 8-15 % (w/v) with the ratio of acrylamide to bisacrylamide 37.5:1. 10 ml of the gel solution contains 1 x TAE buffer, 8-15 % acrylamide, 0.21-0.4 % bisacrylamide, 0.075 % APS, 12 μ l TEMED. Before electrophoresis, the electrophoresis chamber was filled also with 1 X TAE buffer and the gel was prerun for 15-30 min at 70 V. The samples were loaded without adding the loading buffer. The native loading buffer was loaded separately in one well only to trace the migration distance. The gel was electrophoresed at 20 mA for 1.5-2 h. After electrophoresis, the DNA was visualised and autoradiographed by using a phosphoimager Storm 860, Molecular Dynamics (Amersham Biosciences, Buckinghamshire, UK) with the ImageQuANT 5.2 software.

2.4.5.3. Formaldehyde gel for RNA separation

When working with RNA, all solutions and equipment have to be free of RNase. Buffers and solutions except Tris buffer were treated with 0.1 % (v/v) diethyl pyrocarbonate overnight and autoclaved. The electrophoresis system was cleaned with ethanol and 3 % (v/v) H₂O₂. The gel consisted of 1 % agarose, 1 x MOPS buffer, 2 % formaldehyde. RNA (1-2 μ g) was mixed with 2-3 volume of loading buffer, denatured at 65 °C for 10 min then chilled on ice to eliminate the secondary structure of the RNA. Electrophoresis was performed in 1 x MOPS buffer at 40 V overnight. 4-6 μ g RNA marker from BioLabs was used (Biolabs, Hertfordshire, UK). The gel was stained with ethidiumbromide and visualised with a UV transilluminator (IDA system, Raytest, Straubenhardt).

2.4.5.4. Elution of DNA from agarose gel

DNA was recovered from agarose gel by using Easy Pure Kit (Biozym, Oldendorf), following exactly the instruction of the supplier.

2.4.5.5. Pulse field gel electrophoresis (PFGE)

To prepare genomic DNA for PFGE, bacteria were grown in LB medium overnight ($OD_{600nm} = 10^9$). 20 ml of the culture was harvested. The pellet was washed with 1M NaCl, 10 mM Tris/HCl (pH 7.6) and resuspended in 500 μ l EC buffer. An equal volume of melted 1% (w/v) InCert Agarose, prepared in EC buffer and maintained at 45 °C, was added to the cells and mixed to yield a homogenous suspension but without introducing air bubbles. The suspension was immediately pipetted in the 100 μ l plug moulds and allowed them to cool on ice for 10 min. Solidified plugs were incubated at 37 °C, overnight in 1 ml of EC buffer, which additionally contained 20 μ g/ml RNase and 1 mg/ml lysozyme. Subsequently, the plugs were incubated at 50 °C overnight in ES buffer contained 1 mg/ml proteinase K. Proteinase K was inactivated by treating the plugs twice with 1 ml of 1 mM phenylmethylsulfonyl in TE buffer (10:1) at 37 °C. The plugs were further incubated twice in TE buffer to remove phenylmethylsulfonyl. Prepared plugs could be stored at least for two weeks at 4 °C. 2 mm gel slices were cut out of the plugs and loaded on a comb together with the Bacteriophage λ standard. The comb was then embedded into 14 x 14 cm of 1 % (w/v) agarose gel, which was prepared in 0.5 x TBE buffer. Gels were run in a contour-clamped homogenous electric field apparatus (CHEF Mapper, Biorad Laboratories, Richmond, USA) with pulse times of 45 s for 14 h, and 25 s for 6 h, at 210 V and 130 mA in 0.5 x TBE buffer. The gels were stained with ethidiumbromide for 20 min and visualised as described in section 2.4.5.1.

2.4.6. Phenol extraction of DNA

This technique is useful when protein or solute molecules need to be removed from aqueous solution. An equal volume of phenol/chloroform/isoamylalcohol (25:24:1 v/v/v) mixture was added to the DNA solution. The mixture of DNA and solvent was vortexed vigorously and microcentrifuged for 15 s with maximum speed at room temperature. The top phase containing DNA was carefully transferred to a new tube. The DNA solution was further concentrated with ethanol or isopropanol to remove the residual organic solvent and for reasons of convenience (see 2.4.7).

2.4.7. Precipitation of DNA

The DNA solution can be concentrated with 100 % ethanol or isopropanol. 1/10 volume of Na-acetate (3 M, pH 5.2) was added to the DNA solution. The mixture was vortexed briefly and mixed with 2-2.5 volume (calculated after salt addition) of ice-cold 100 % ethanol. The precipitation step was done in a -70 °C freezer for 15 min or in a -20 °C freezer for at least 30 min. If isopropanol was used, only 0.7 volume of isopropanol was added to the mixture. The DNA was then microcentrifuged for 5 min at maximum speed and removed the supernatant. The DNA pellet was washed with 1 ml of room-temperature ethanol (70 % v/v) and centrifuged as before. The DNA pellet was dried in a Speedvac evaporator, then dissolved in an appropriate volume of water or TE buffer (10:0.1).

2.4.8. Enzymatic manipulations of DNA

2.4.8.1. Restriction enzyme digestion

DNA was digested with restriction endonucleases for restriction enzyme analysis or cloning. The enzymes were used according to the instructions of the suppliers. In general, 0.5-1.0 µg DNA in a volume of 10-20 µl in 1 x reaction buffer was treated with 3 U enzyme and incubated for 2 h at the optimal temperature. For genomic restriction digestion, 10 µg DNA in 100 µl reaction volume in 1 x buffer was treated with 20 U enzyme overnight. The digested products were analysed by electrophoresis.

2.4.8.2. Dephosphorylation of 5' ends of DNA fragments with alkaline phosphatase

To dephosphorylate the 5' phosphate of the vector after enzyme digestion, the DNA was precipitated with isopropanol and resuspended in 17 µl TE (10:0.1) plus 2 µl (10 x) dephosphorylation buffer and 1 µl alkaline phosphatase (10U). The reaction was performed at 37 °C for 1 h. Afterwards, the DNA was purified by phenol or gel extraction.

2.4.8.3. Phosphorylation of DNA termini with T4 polymerase kinase

1-20 pmol of DNA was mixed in a 20 µl volume with 2 µl (10 x) reaction buffer A, 20 pmol ATP and 10 U T4 polymerase kinase. The reaction was incubated at 37 °C for 30 min. The reaction was stopped by phenol extraction.

2.4.8.4. Filling the 3' recessed termini of DNA fragment with Klenow enzyme

For filling the 3' recessed termini of the double strand DNA, 0.5-1µg of restricted DNA was precipitated with isopropanol and resuspended in 15 µl TE (10:0.1) plus 2 µl (10 x) buffer, 0.2 mM dNTP mixed and 1 µl Klenow fragment (2U). The reaction was carried out at 37 °C for 20 min and the enzyme was inactivated by heating at 70 °C for 10 min. The DNA was then purified by phenol or gel extraction.

2.4.8.5. Creating blunt ends with T4 DNA polymerase

The reactions were carried out in a 20 µl reaction volume with 4 µl (5 x) buffer, 100 µM dNTP mixed and 1 U T4 DNA polymerase at 11 °C for 20 min. The reaction mixture was inactivated by heating at 70 °C for 10 min. The DNA was then purified by phenol or gel extraction.

2.4.8.6. Ligation

The ligations were performed in a 20 µl reaction volume with 1 x ligation buffer at 16 °C overnight. The insert DNA was used in an equal or up to 3 fold molar concentration over vector DNA. For ligation of DNA with sticky ends, 1 U ligase was used. For the DNA with blunt ends, the reaction was supplemented with 2 µl 50 % PEG 4000 and 2 U ligase instead of 1 U. The resulting ligation reaction mixture was heated at 65 °C for 10 min to inactivate T4 DNA ligase and used directly for transformation.

2.4.8.7. Labeling DNA with Digoxigenin

For hybridisation of Southern blots, the DNA used as the probe was labeled using Random Primed DNA Labeling Kit (Roche Molecular Biochemicals, Mannheim). In a polymerisation reaction with Klenow-Fragment, the digoxigenin deoxyuridine triphosphate (Dig-dUTP) will be incorporated into the newly synthesised DNA strand. The primer for Klenow enzyme was a mixture of all the possible combination of hexanucleotides. The DNA after PCR or restriction digestion was extracted from an agarose gel and resuspended in 15 µl water or TE buffer 10:0.1. The DNA was denatured by boiling for 10 min and chilled quickly on ice. The reactions were set up in following order:

DNA (0.1-1 µg)	15 µl
Hexanucleotide mixture	2 µl
dNTP mixture	2 µl
Klenow- Fragment	1 µl (2 U)

The labeling reactions were incubated at 37 °C for at least 1 h and stopped by adding 2 µl of 0.2 M EDTA, pH 8.0. The labeled DNA can be used directly for hybridisation or after being precipitated with ethanol and 2.5 µl 3 M LiCl at -70 °C for 30 min.

2.4.8.8. Labeling RNA with Digoxigenin

For Northern hybridisation, the RNA was labeled by *in vitro* transcription using the Dig Northern Starter Kit (Roche Molecular Biochemicals, Mannheim). The anti-sense DNA was cloned into pBluescript II SK (+) and linearised at a restriction site downstream of the cloned insert leaving 5' overhang ends. The linearised DNA was then purified by phenol, chloroform extraction, precipitated and resuspended in 10 µl water. The *in vitro* transcription was performed in 20 µl volume with 1 µg DNA, 4 µl labeling mix (containing Dig-dUTP), 4 µl of 5 x transcription buffer and 2 µl RNA polymerase T7 or T3 at 42 °C for 1 h. The reaction was incubated with 20 U of DNase at 37 °C for 15 min to remove the template DNA. The reaction was stopped by adding 2 µl EDTA (0.2 M, pH 8.0). The RNA probes were stored at -20 °C.

2.4.9. Transfer DNA into *E. coli* or *Rhodococcus*

2.4.9.1. Preparation of *E. coli* competent cells (Inoue et al. 1990)

A single colony of the *E. coli* strain was cultured in 2 ml LB medium at 37 °C overnight. 2 ml overnight culture was subcultured in 200 ml SOB medium at room temperature or 30 °C until the culture reached $OD_{600} = 0.4-0.6$. The cells were then cooled on ice for 10 min and centrifuged at 5000 rpm, 4 °C for 10 min (Sigma 3K-1, Deisenhofen). The pellet was resuspended in 80 ml ice-cold transformation buffer and placed on ice for 10 min. The suspension was centrifuged again under the same condition for 10 min. The buffer was then removed and changed with 20 ml of fresh transformation buffer supplemented with 7 % DMSO. The suspension was cooled on ice for another 10 min and aliquoted 100 or 200 µl in

microcentrifuge tubes. The competent cells were used immediately or frozen in liquid nitrogen and stored at -70 °C.

2.4.9.2. Transformation of *E. coli* (Inoue et al. 1990)

The competent cells were thawed at room temperature and used immediately. 1-5 µl (10 pg-10 ng) of plasmid was added to 100-200 µl competent cells and incubated on ice for 15-30 min. The cells were then heat-pulsed without agitation at 42 °C for 30 s and transferred to ice for 2 min. After 0.9 ml of SOC medium was added, the tube was incubated by shaking vigorously at 37 °C for 1 h. A desired portion of the culture was spread on a selective medium for the transformants.

2.4.9.3. Preparation of *E. coli* competent cells for electroporation (Dower et al. 1988)

A single colony of an *E. coli* strain was cultured overnight in 2 ml LB at 37 °C, 150 rpm (RFI-125, Infors AG, Bottmingen, Switzerland). 2 ml of the grown culture was inoculated into 200 ml LB and cultured under the same condition to an OD₆₀₀ = 0.4-0.6. The cells were then chilled on ice for 10 min and centrifuged at 5000 rpm, 4 °C for 10 min to remove the supernatant. The cells were washed twice in 200 ml ice cold water. For direct use, an equal volume to the cells pellet of water was added to the cells and mixed. The suspension was aliquoted to 100 µl of cells. For storage, 20 ml ice cold 10% (v/v) glycerol was added to the cells and mixed well. The cells were precipitated as before by centrifuging. An equal volume to the cell pellet of ice cold 10 % (v/v) glycerol was used to resuspend the cells. An aliquot of 100 µl cells was placed into a prechilled microcentrifuge tube, frozen on dry ice and stored at -70 °C.

2.4.9.4. Preparation of *Rhodococcus* competent cells for electroporation

Rhodococcus rhodochrous ATCC12674 was cultured in LB medium at 30 °C and the protocol for preparation of electroporation *E. coli* competent cells was followed (Hashimoto et al.1992).

For other *Rhodococcus* strains, the cells were grown in LB medium supplemented with 10 % (w/v) sucrose and 1 % (w/v) glycine at 30 °C on a rotating wheel (Mobiplex 44, Stöber) to OD₆₀₀ = 1-1.2. The cultures were stored at 4 °C without further treatment, in which case

transformation efficiency did not change significantly for two months. Alternatively, the cells were washed three times with the same volume of sterile water and finally resuspended in water (see 2.4.9.3).

2.4.9.5. Transformation by electroporation

0.01-1 µg DNA was added to 100 µl of fresh or thawed competent cells and left on ice for 15 min. The mixture was transferred to a prechilled 1 mm gap cuvette. The volume of the DNA should be kept small. Adding up to one-tenth of the cell volume will decrease the transformation efficiency. The total salt concentration in the cuvette was ≤ 1 mM. Electroporation was performed at 20 kV, 25 µF capacitance, 200 Ω for *E. coli* and 400 Ω for *Rhodococcus*. The cuvette was placed on ice for 10 min, 0.9 ml LB was added and incubated on a shaker at 37 °C for 1 h in the case of *E. coli* and 30 °C for at least 3 h in the case of *Rhodococcus*. The cells were plated on selective medium containing the relevant antibiotic.

2.4.9.6. Conjugation by filter mating

For conjugal transfer of DNA from *E. coli* to *R. opacus* HL PM-1, the recombinant plasmids were transformed into *E. coli* S17.1. The *E. coli* strain was cultured overnight in 5 ml LB medium supplemented with 30 µg/ml kanamycin. *R. opacus* HL PM-1 was cultured in 5 ml LB medium for 24 h. Both cultures were harvested and washed twice with salt solution by centrifuging at 5000 rpm for 10 min. The pellets were then resuspended in 400 µl fresh LB medium each. The two strains were mixed in ratios of 1:2; 1:1; 2:1 in a 200 µl volume. The mixtures were pipetted on filters (25 mm diameter, Sartorius), placed on LB agar plates for 2 days at 30 °C. The membranes were washed with salt solution and the suspensions were spread onto LB medium containing 80 µg/ml kanamycin plus 20 µg/ml nalidixic acid to select for transconjugants.

2.4.10. Gel mobility shift assay (GMSA)

The DNA-binding assay uses nondenaturing polyacrylamide gel electrophoresis for detecting sequence-specific DNA-binding proteins. Protein that binds specifically to an end-labeled DNA fragment retards the mobility of the fragment during electrophoresis, comparing to the free DNA. The DNA was labeled with fluorescent Cy5 by using labeled primers for PCR. The DNA binding reactions were performed in a 10 µl volume consisting of 1 x GMSA buffer,

0.001-10 mM DNP, 1-5 ng of labelled DNA fragment, cell extract containing heterologously expressed NpdR (100-300 ng protein) or His-tag purified NpdR (50-200 ng). The reaction mixtures were subject to electrophoresis and the labeled DNAs were detected with a Phosphoimager (Storm 860, Molecular Dynamics, Amersham Biosciences, Buckinghamshire, UK) and the ImageQuaNT 5.2 software.

2.4.11. Polymerase chain reaction (PCR)

PCR was performed in a T Gradient Thermocycler 96 (Biometra GmbH, Göttingen). Reaction mixtures of 25 µl contained plasmid DNA (10 ng) or genomic DNA (100 ng), 1 x reaction buffer, 25 pmol of each primer, 1.5 mM MgCl₂, 4 % (v/v) DMSO, 0.2 mM of each dNTP and 0.5-1 U Tag polymerase. The reactions performed with Pwo polymerase with proof reading activity were as above, except that 1.5 U of enzyme and 2.0 mM Mg₂SO₄ were used. The PCR was started with 3-4 min at 94 °C to denature the DNA template and continued with 25-30 cycles. Each cycle consisted of 30s at 94 °C denaturation, 30 s at annealing temperature for the primers to hybridise to the target sequence and a extension time for polymerisation at 72 °C. The annealing temperature is 10 °C lower than the calculated melting temperature of the primers (T_m).

$$T_m = [4\text{ °C} \times \sum (G+C)] + [2\text{ °C} \times \sum (A+T)]$$

The extension time is 1 min for 1 kb DNA. The longer the DNA fragment, the longer is the extension time needed. Finally, the PCR was completed with 5-10 min at 72 °C to ensure that all the PCR products were full lengths.

All primers used in this study are listed in Table 4. They were purchased from Eurogentec (Seraing, Belgium) and MWG Biotech (Ebersberg).

Table 4. Oligonucleotides used in this study

Number	Oligo name	Nucleotide sequence 5'→3'	Cloning site	Coding sequence
1	Val- <i>npdR</i> -for	CGACATATGCCCGCCATC TCGCGC	<i>Nde</i> I	<i>npdR</i> gene
2	Bam- <i>npdR</i> -rev	CGCGGATCCTCAGCCGCG CCCGGCGCCGAG	<i>Bam</i> HI	<i>npdR</i> gene

3	GMSA1-for	CY5-TTGCTGCGCGCC CGCCATTTC	No	Labeled IGRI' ^a
4	GMSA1-rev	CY5-CACAAGCTCCGT TCACTA	No	Labeled IGRI'
5	GMSA2-for	CY5-TGACAGCATTCG CACGAC	No	Labeled IGRII' ^b
6	GMSA2-rev	CY5-CAGCTGCTCGCT GGATTG	No	Labeled IGRII
7	GMSA3-for	CY5-CCGAGCCCCGA TTTCA	No	Labeled IGRIII' ^c
8	GMSA3-rev	CY5-GTCTGTCTCCTA CACATTG	No	Labeled IGRIII
9	GMSA4-for	CY5-GCACCGAGAGC GACGGGCCGC	No	Labeled IGRIV' ^d
10	GMSA4-rev	CY5-CGAACTTCTCT CATGATGTTGAAC	No	Labeled IGRIV'
11	EcoRI-P1	CGGAATTCCTTTCGTTTC GCGTTGCTGC	<i>EcoRI</i>	IGRI'
12	BamHI-P1	CGGGATCCCATCACAAGC TCCGTTAC	<i>BamHI</i>	IGRI'
13	EcoRI-P2-for	CCGGAATTCCTGATCACC CCGTCATACGC	<i>EcoRI</i>	IGRIV'
14	KpnI-P2-rev	GGGGTACCGAACTTCTCT TCATGATGTTGAAC	<i>KpnI</i>	IGRIV'
15	EcoRI-KO	GAGAATTCGGCGGAACT CCGTGAACTCG	<i>EcoRI</i>	1102 bp flanking sequence of deleted region of <i>npdR</i>
16	KpnI 1-rev	TGAGGTACCCGTCCGGCA TCGGCTGG	<i>KpnI</i>	1102 bp flanking sequence of deleted region of <i>npdR</i>
17	BamHI-KO	GGGGATCCTGCGGTGCA GGTCCTCG	<i>BamHI</i>	1083 bp flanking sequence of deleted region of <i>npdR</i>
18	KpnI 2-for	ATAGGTACCGGAACTCA ACGTCGTGG	<i>KpnI</i>	1083 bp flanking sequence of deleted region of <i>npdR</i>

19	EcoRI-IGR2	CAGAATTCGCACGACGA AGGTAGG	<i>EcoRI</i>	IGRII
20	KpnI-IGR2	CGGGTACCAGCTGCTCGC TGG	<i>KpnI</i>	IGRII
21	KO-orfA1-for	CGCCTGACCGACCGCTTC ACC	No	994 bp flanking sequence of deleted <i>orfA1</i>
22	ClaI-orfA1-rev	CCATCGATTGCTCGAGCA CGCGG	<i>ClaI</i>	994 bp flanking sequence of deleted <i>orfA1</i>
23	ClaI-orfA1-for	GAATCGATCACCTCCGCT CGCGTTG	<i>ClaI</i>	1139 bp flanking sequence of deleted <i>orfA1</i>
24	KO-orfA1-rev2	CGTCGATCAGAGCCTCGG CAC	No	1139 bp flanking sequence of deleted <i>orfA1</i>
25	OrfA1-for	GCTTTTCCATATGCTCGA GACTCTC	<i>NdeI</i>	<i>orfA1</i> gene
26	OrfA1-rev	AGAGGATCCGAGTAGAT CACCACGG	<i>BamHI</i>	<i>orfA1</i> gene
27	Cy5-DR-for	CY5-GTGGAGTTCCA AATAATGAT	No	Labeled direct repeat sequence from IGRI'
28	OrfA2 probe-for	TGACCGCTGAACCCTGCT GACCCGC	No	456 bp <i>orfA2</i> probe
29	OrfA2 probe-rev	TGATTCGGTTGTTCCCGC TTTAGCCG	No	456 bp <i>orfA2</i> probe
30	KO-orfA2-for	GTGAATTCGGGTGGTCTGA CCGGAGAC	<i>EcoRI</i>	994 bp flanking sequence of deleted region of <i>orfA2</i>
31	ClaI1-orfA2	AGATCGATCACCTCTTGC GTGGTGATCC	<i>ClaI</i>	994 bp flanking sequence of deleted region of <i>orfA2</i>
32	ClaI2-orfA2	ATATCGATCCGGGAGGA ATCCGGGTCG	<i>ClaI</i>	1139 bp flanking sequence of deleted region of <i>orfA2</i>
33	KO-orfA2-rev	GTGGATCCGGAGGTGCTC GGCGGTTG	<i>BamHI</i>	1139 bp flanking sequence of deleted region of <i>orfA2</i>
34	npdc probe- for	ATGAAGGTCGGAATCAG GATCCCG	No	517 bp of <i>npdC</i>

35	npdc probe-rev	GGGTACATCTTGAAGTCG TGGAGC	No	517 bp of <i>npdC</i>
36	DH2-Nde-for	TTTGATCATATGATCAAA GGCATCCAGCTCC	<i>NdeI</i>	<i>npdI</i> gene
37	DH2-Bam-rev	GAGGATCCTCATGCGAGC TCCGGCAG	<i>BamHI</i>	<i>npdI</i> gene
38	OrfA1 probe-for	GCTTTTCCGGATGCTCGA GACTCTC	No	1474 bp contains <i>orfA1</i>
39	OrfA1 probe-rev	TGGCGGGCGATTCGGTCC	No	1474 bp contains <i>orfA1</i>
40	NdeI- <i>npdR</i> -FJ	TGCCCAGCATATGCCCCGC GGTGAGTC	<i>NdeI</i>	<i>npdR</i> from <i>N. simplex</i> FJ2-1A
41	BamHI- <i>npdR</i> -FJ	TGGGATCCGGTCAGCCGA GAGTCGG	<i>BamHI</i>	<i>npdR</i> from <i>N. simplex</i> FJ2-1A

^a: 157 bp, 3' end of the intergenic region between *orfA* and *orfB*; ^b: intergenic region between *npdF* and *npdR*; ^c: intergenic region between *npdR* and *npdG*; ^d: intergenic region between *npdH* and *npdI* plus the 3' end of *npdH*.

2.4.12. Transferring DNA to nylonmembrane

2.4.12.1. Colony lifting

The agar plates with colonies were pre-cooled at 4 °C for 30 min. The membrane disc was carefully placed onto the surface of the plate for 1 min. The orientation of the plate was marked on the membrane in order to be able to identify positive colonies. The membrane disc was removed with tweezers and briefly blotted (colonies up side) on a Whatman 3 MM paper. The membrane up side, was placed for 5 min on a prepared Whatman paper soaked with 10 % (w/v) SDS. The membrane was air-dried on Whatman 3 MM paper briefly. The membrane was then treated with denaturation solution for 15 min, neutralisation solution for 15 min and 2 x SSC for 10 min using the same way, on the prepared soaked Whatman paper. After every single treatment, the membrane was briefly air dried on Whatman 3 MM paper. Subsequently, the membrane was UV cross-linked at 254 nm (Min UVIS, Desaga, Heidelberg) for 3 min or baked at 80 °C for at least 30 min. The membrane was then used for prehybridisation.

2.4.12.2. Southern blotting

After electrophoresis, the DNA was transferred to a positively charged nylon membrane by vacuum blotting at 500-600 mmHg for 2 h. First, the gel was pre-treated with 0.25 M HCl for 15-30 min to partially depurinate the DNA, which in turn leads to the strand cleavage. This step is important to improve the transfer of DNA > 4 kb in length. The time needed for the acid treatment depends on the concentration and thickness of the gel. When the xylene cyanol and bromophenol blue dyes changed to green and yellow respectively, the gel was equilibrated with acid. Adequate depurination took a further 10 min. The acid solution was then replaced with denaturation solution and incubated approximately 20 min until the colour of xylene cyanol and bromophenol reverted back to the original colour. The gel was further neutralised by treating with neutralisation solution for 20 min. This step is to bring the pH down to < 9.0. Finally the gel was blotted with 20 x SSC for 1 h. After blotting, the membrane was air dried and UV cross-linked at 254 nm for 3 min to immobilise the DNA, and washed briefly with 2 x SSC. The membrane can be stored dry between sheets of Whatman paper for several months at room temperature.

2.4.12.3. Northern blotting

After electrophoresis, the gel was rinsed with several changes of sufficient RNase-free water to remove formaldehyde. The gel was then transferred to a positively charged nylon membrane for 4 h with only 20 x SSC under the same condition used for Southern blotting (see 2.4.12.2). HCl and NaOH were not used. The RNA was immobilised also by using UV transilluminator for 3 min, and washed to remove SSC and dried as above.

2.4.12.4. DNA dot blotting

For DNA dot blotting, the DNA (50-300 ng) was denatured at 100 °C for 10 min in 0.4 M NaOH and 10 mM EDTA. After placing the samples on ice, an equal volume of 20 x SSC was added to each sample. The samples were spotted onto the membrane using a pipet and allowed to dry. If the sample volume was > 3 µl, it was applied in successive 3 µl aliquots each spot being allowed to dry before the next aliquot was applied. The membrane was UV cross-linked, washed and dried as in Southern blotting (see 2.4.12.2).

2.4.12.5. RNA dot blotting

Three volumes of denaturing solution (500 μ l formamide, 162 μ l formaldehyde, 100 μ l MOPS buffer) were added to each sample containing 50-500 ng RNA. The samples were incubated at 65 °C for 15 min, then placed on ice. Two volumes of ice cold 20 x SSC were mixed with the sample. The samples were then spotted onto the membrane as for DNA dot blotting. The RNA was immobilised with UV radiation and washed with 2 x SSC.

2.4.12.6. Transferring of DNA under alkaline condition

Gels were depurinated twice in 0.25 M HCl for 10 min, denatured twice in 0.4 M NaOH for 10 min, and transferred onto a positively charged nylon membrane overnight by capillary transfer. The DNA was immobilised with UV radiation and washed with 2 x SSC as described above (see 2.4.12.2).

2.4.13. Hybridisation

2.4.13.1. Southern hybridisation

Southern hybridisation was accomplished by using the Nonradioactive Dig DNA Labeling and Detection Kit (Roche Molecular Biochemicals, Mannheim) and following the instruction of the supplier. The membrane was prehybridised in hybridisation buffer at 68 °C for at least 1 h. The buffer was then replaced with 10 ml (for 100 cm² membrane) of hybridisation buffer containing 10-50 ng/ml of freshly denatured labeled DNA. The labeled DNA was denatured by boiling for 10 min and chilled immediately on ice containing NaCl. The membrane was hybridised with the probe at 60-68 °C for 16 h. This step could be shorted if a higher concentration of DNA was used. The membrane was washed twice with 2 x SSC; 0.1 % (w/v) SDS for 5 min at room temperature and further washed twice with 0.1 x SSC; 0.1 % (w/v) SDS at 68 °C for 15 min. The washed membrane was submerged in buffer H1 for 1 min and incubated for 30 min in 100 ml buffer H2. The membrane was incubated with 20 ml buffer H2 containing 4 μ l of antibody conjugate (1:5000 dilution) for 30 min at room temperature. The unbound antibody conjugate was removed by washing the membrane twice with washing buffer for 15 min. The membrane was equilibrated for 2 min with buffer H3. The detection reaction was started as adding 10 ml buffer H3 containing 45 μ l of NBT and 35 μ l of X-phosphate to the membrane. The reaction was performed in a dark box without shaking for

several hours or overnight. When the desired spots or bands were detected, the reaction was stopped by washing the membrane thoroughly with water. The membrane was dried or kept in water for reprobing.

2.4.13.2. Northern hybridisation

Northern hybridisation was performed using Dig Northern Starter Kit (Roche Molecular Biochemicals, Mannheim) and following the manual. The Northern hybridisation procedure used was similar to Southern hybridisation except that it was performed only at 68 °C in Dig Easy Hyb. buffer with 100 ng/ml Dig-labeled RNA probe. The RNA probe was boiled for 5 min and cooled on ice before applying it to the membrane. For detection, the membrane was incubated with 1:10000 diluted antibody conjugate. After equilibration with detection buffer H3, the membrane was placed (with the RNA side facing up) on a hybridisation bag and approximately 1 ml of CDP-Star solution was applied quickly to the membrane. The membrane was immediately covered with the second sheet of the bag to spread the substrate evenly over the membrane. All edges of the bag were then sealed. The sealed membrane was exposed to X-ray film for 15-25 min at 15-25 °C. Multiple exposures were taken to achieve the desired signal strength.

2.4.13.3. Stripping Southern blots

Only the wet membrane can be stripped. The membrane was incubated in heated dimethylformamide at 50-60 °C until the colour was removed. The membrane was rinsed thoroughly in distilled water and washed twice in 0.2 M NaOH, 0.1 % (w/v) SDS at 37 °C for 20 min to remove the Dig labeled probe. The membrane was then washed thoroughly in 2 x SSC, air dried and directly used for hybridisation.

2.4.14. Sequencing

Sequencing was performed commercially by GATC Biotech AG (Konstanz, Germany) using Run24 Supreme (http://www.gatc.de/home_flash.htmusing).

2.4.15. Computer analysis

Sequence similarity searches were performed with BLASTN, BLASTP, BLASTX from NCBI (National centre for Biotechnology Information). Pairwise and multiple alignments were carried out by using BLAST2 (<http://www.ncbi.nlm.nih.gov/BLAST>) and CLUSTALW (<http://www.ebi.ac.uk/clustalw>). Conserved domain searches were performed with the tool CD-search tool (<http://www.ncbi.nlm.nih.gov>). Helix-turn-helix motif searches were performed using the detection method of helix-turn-helix DNA-binding motifs in protein sequences (Dodd, 1990) (http://npsa-pbil.ibcp.fr/cgi-bin/npsa_automat.pl?page=/NPSA/npsa_hth.html). Sequence analysis was performed using DNA Star (DNASTAR, Inc) (<http://www.dnastar.com>). Promoter regions were identified with the program Promoter Finder (http://www.mgs.bionet.nsc.ru/mgs/programs/bdna/tata_bdna.html).

2.5. Protein analytical methods

2.5.1. Preparation of crude extract

E. coli cells were harvested by centrifuging at 5000 rpm, 4 °C for 10 min, washed and resuspended in appropriate buffer. For a small volumes 1-2 ml suspension, the cells were sonicated 2-3 times for 30 s on ice with 50 % pulse/s, microtip 4.8 mm, level 4 (Sonicator W-385, Heat Systems Ultrasonics, NewYork, USA). For larger volumes and denser suspensions, the cells were lysed using a French press (Amico, Illinois, USA) at 80 MPa twice. The cell debris was removed by centrifuging at 30 000 rpm, 4 °C for 30 min (Ultracentrifuge Beckman optima LE 80K, California, USA).

Rhodococcus cells were cultured in Erlenmeyer flasks without baffles in minimal medium to $OD_{600} = 0.7-0.8$ and harvested by centrifuging at 5000 rpm, 4 °C for 10 min. The pellet was then frozen in liquid nitrogen before being passed through the French press twice. An alternative method used was cultures grown in LB or minimal medium supplemented with 10 % (w/v) sucrose plus 1 % (w/v) glycine and lysed by sonication as above.

2.5.2. Determination of protein concentration (Bradford, 1976)

The samples were diluted in water to a protein concentration of 20-100 µg protein/ml. The BSA standard solutions were prepared in the range from 0-120 µg protein/ml. 100 µl of diluted sample or BSA solution was mixed with 900 µl of 1:5 diluted dye reagent concentrate

(Bio-Rad, Protein assay). After 10-20 min incubation at room temperature, the reaction mixtures were measured at a wavelength of 595 nm using 1 cm path length cuvettes (Varian Carry 50 Bio Spectrophotometer, Victoria, Australia). A calibration curve was created by plotting absorbance versus concentration of the standards (Cary WinUV Biopackage software). The protein concentrations in the samples were then determined from the calibration curve according to the absorbance of the samples.

2.5.3. Determination of nitrite concentration (Montgomery and Dymock, 1961)

Reagent solutions:

Solution 1: 0.1 % N-(1-naphthyl)-ethyldiamin in H₂O

Solution 2: 0.3 % sulfanilamid in H₂O

The reaction solution was prepared freshly by mixing 25 ml solution 1 with 5 ml solution 2 plus 5 ml acetic acid. One volume of the sample was mixed with two volumes of the reaction solution and incubated at room temperature for 15 min. The samples were measured at a wavelength of 540 nm using 1 cm path length cuvettes. The nitrite concentration was calculated by using the calibration curve from 0.01-0.04 mM of standard solution.

2.5.4. High performance liquid chromatography (HPLC)

The metabolites were detected by means of HPLC using the following system:

Pump:	Dionex, P580
Degass system:	Dionex, DG 1210
Detector:	Dionex UV / Vis, UVD 170S/340S
Autosampler:	Dionex, Gina50
Software:	Chromeleon Chromatography Data System 4.3

The samples were resolved on Gromsil 100 Octyl-4 columns (125 x 4 mm, particle size 5 µm, Grom) using 25 mM KH₂PO₄/K₂HPO₄ buffer, pH 8.0 plus 30 or 40 % (v/v) methanol and 5 mM PicA (tetrabutylammonium hydrogensulfate) as mobile phase. The precolumn was a Gromsil 100 Octyl-4 column (20 x 4 mm, particle size 5 µm, Grom).

2.5.5. SDS - Polyacrylamide gel electrophoresis (Laemmli, 1970)

Proteins are separated based on their molecular size as they move through a polyacrylamide gel matrix towards the anode. The polyacrylamide gel was cast as a separating gel and topped

by a stacking gel. The following volumes of gel solution were prepared for 2 gels (0.75 mm × 7 cm × 10 cm, Bio-Rad).

	10 % separating gel	15 % separating gel	4 % stacking gel
Acrylamide:Bisacrylamide (30 % : 0.8 %)	5 ml	7.5 ml	0.65 ml
1.5 M Tris/HCl pH 8.8	3.75 ml	3.75 ml	
0.5 M Tris/HCl pH 6.8			1.25 ml
10 % SDS	0.15 ml	0.15 ml	0.05 ml
H ₂ O	6.04 ml	3.54 ml	3.02 ml
10 % APS	0.05 ml	0.05 ml	0.025 ml
TEMED	0.01 ml	0.01 ml	0.005 ml
Total volume	15 ml	15 ml	5 ml

The separating gel was allowed to polymerise for 1 h. The stacking gel was poured on top of the separating gel and allowed to polymerise for 30 min. After the comb had been removed, the wells were rinsed with 1 x running buffer. The samples were diluted 1:4 with 5 x SDS loading buffer and boiled for 5 min before loading. Electrophoresis was performed at 4 °C, 70 V until the bromphenol blue tracking dye entered the separating gel, increased the voltage to 120-140 V. After the tracking dye had reached the bottom of the separating gel, electrophoresis was terminated. The gel was then stained with staining solution for 30 min and destained in destaining solution. 10 µl of low molecular weight protein mixture (Amersham Biosciences) was used as the standard.

2.5.6. Enzyme assays

All enzyme assays were performed with a Varian Carry 50 Bio spectrophotometer and the Cary WinUV Biopackage software. The specific activity was calculated using the following equation:

$$\text{Specific activity} = \frac{V}{\epsilon d c v} \times \frac{\Delta\epsilon}{\Delta t} \quad \text{Units/mg}$$

V: total volume in assay mixture (ml)	c: protein concentration (mg/ml)
ϵ : extinction coefficient (liter/mol/cm)	v: volume of protein in assay mixture (ml)
d: light path of cuvette (cm)	$\frac{\Delta\epsilon}{\Delta t}$: change in absorbance per minute
	Δt

One unit of the enzyme activity is the amount of enzyme that catalyses the conversion of 1 micromole of substrate to product in 1 minute under the conditions of the assay.

2.5.6.1. Catechol-2,3-dioxygenase (C23DO) assay

The enzyme activity of C23DO was measured in a total volume of 1 ml in 100 mM $\text{KH}_2\text{PO}_4/\text{K}_2\text{HPO}_4$ buffer, pH 7.5, with 0.2 mM catechol plus 8-15 μg protein. The reactions were initiated by addition of cell extracts. The increase in absorbance was monitored at 375 nm for 2 min. Reaction rates were calculated by using an extinction coefficient of 36 000 $\text{M}^{-1}\text{cm}^{-1}$.

2.5.6.2. HTI enzyme assay

The HTI catalyses the conversion of H-TNP to 2H-TNP. The reaction was monitored at 485 nm for 30 s in 1 ml 50 mM $\text{KH}_2\text{PO}_4/\text{K}_2\text{HPO}_4$ buffer, pH 7.5. The following was added to the enzyme assay: 0.1 mM H-TNP, 125 μM NADPH, 13 μM F_{420} and 5 μg purified NpdG. Reaction rates were calculated using an extinction coefficient of 8535 $\text{M}^{-1}\text{cm}^{-1}$. H-TNP was synthesised by Klaus Hofmann (Hofmann, 2003).

2.5.6.3. HTII enzyme assay

The HTII catalyses the conversion of TNP to H-TNP. The reaction was monitored at 485 nm for 30 s in 1 ml 50 mM $\text{KH}_2\text{PO}_4/\text{K}_2\text{HPO}_4$ buffer, pH 7.5. The following was added to the enzyme assay: 0.1 mM TNP, 125 μM NADPH, 13 μM F_{420} and 5 μg purified NpdG. Reaction rates were calculated using an extinction coefficient of 8535 $\text{M}^{-1}\text{cm}^{-1}$.

2.5.7. Purification of proteins

2.5.7.1. NpdR His-tag fusion protein

The His-tag fusion protein of NpdR was purified from induced cultures of *E.coli* BL21 (DE3) (pNGA5) by Ni-NTA metal affinity chromatography by following the instruction of the supplier (Qiagen, Hilden). 100 ml of culture after induction with 1mM IPTG for 4 h at 30 °C, was harvested. The pellet was resuspended in 2 ml of His-tag loading buffer, lysed by French press and centrifuged as described above. The lysate was applied to a Ni-NTA column containing 320 µl Ni-NTA (10 mg His-tag protein/ml Ni-NTA) pre-equilibrated with 2 ml His-tag loading buffer. The column was washed 3 times with 320 µl of the same buffer, 3 times with 320 µl His-tag washing buffer 1 and 3 times with the same volume of washing buffer 2. The His-tag protein was eluted 5 times with 200 µl His-tag elution buffer. The fractions after every step were collected and analysed by SDS-PAGE. The purified fractions were desalted by using pD10 columns (Amersham Pharmacia Biotech) with 50 mM Tris/HCl buffer pH 7.5 and subsequently concentrated by a Vivaspin 2 ml concentrator (Sartorius).

2.5.7.2. NDFR His-tag fusion protein

The NDFR was purified from induced cultures of *E.coli* BL21 (DE3) (pSLK4) by Ni-NTA metal affinity chromatography, desalted and concentrated as described above (see 2.5.7.1).

2.6. Chemicals and biochemicals

All chemicals used in this work were purchased from following companies: Aldrich (Steinheim), Fluka (Buchs, Switzerland), Gerbu (Gaiburg), ICN (Ohio, USA), Merk (Darmstadt), Riedel-de Haen (Seelze), Roth (Karlsruhe) and Sigma (Deisenhofen). Agarose was from Biozym (Oldendorf). Enzymes were from MBI Fermentas (St. Leon-Rot), New England Biolabs (England) and Roche (Mannheim). H-TNP and 2H-TNP were synthesised by Klaus Hofmann (Hofmann, 2003).

3. Results

3.1. Promoter regions in the *npd* gene cluster

3.1.1. Consensus sequences in the *orfA-orfB* and *npdH-npdI* intergenic regions

To identify possible regulatory regions, the *npd* gene cluster was examined for intergenic regions. An intergenic region of 275 bp occurs between *orfA* and *orfB* (IGRI). A putative promoter region was identified in IGRI with a score of 0.92 (Fig.3). Two further IGRs, IGRII between *orfF* and *npdR* (98 bp length) and IGRIII, between *npdR* and *npdG* (131 bp length) exist. No putative promoter regions in these IGRs were identified. Analysis of a fourth intergenic region (IGRIV) between *npdH* and *npdI* (102 bp length) revealed a putative promoter region with a score of 0.62 (Fig.3).

In both putative -35 and -10 boxes of IGRI and IGRIV, 5 out of 6 nucleotides were identical. Direct repeats were detected (see Fig.3).

3.1.2. Expression of *xylE* under the control of IGRI' and IGRIV'

To show that IGRI and IGRIV contain promoters, respective regions were cloned upstream of a promoterless reporter gene *xylE* in pK4. IGRI' (157 bp, 3' end region of IGRI) was amplified using EcoRI-P1 and BamHI-P1 primers (Table 4, number 11, 12) (see Fig.3). The PCR fragment was digested with *EcoRI* and *BamHI* and inserted upstream of the promoterless *xylE* gene in pJOE814.2 to produce pNGA6. IGRI' plus *xylE* were subsequently cut out of pNGA6 as a single *HindIII*-fragment and ligated with the shuttle vector pK4 (cut with *XbaI*) to produce pNGA7. To construct the reporter shuttle vector pNGA8, *xylE* was cut out of pJOE814.2 as *XbaI*-fragment and ligated with pK4 to produce pNGA8. IGRIV' (134 bp region contains IGRIV and the 3' end of *npdH*, see Fig.3) was amplified using EcoRI-P2-for and KpnI-P2-rev primers (Table 4, number 13, 14) and introduced into *EcoRI* and *KpnI* sites of pNGA8 resulting in pNGA9.

The plasmids pNGA8, pNGA7, pNGA9 were transformed into *R. rhodochrous* ATCC 12674. The strain does not grow on TNP or DNP as sole nitrogen source, so it was used in preference to *R. opacus* HL PM-1. Cell extracts were prepared from mid-log phase cultures of *R. rhodochrous* ATCC 12674 containing pNGA7 (*xylE* under control of IGRI'), pNGA9 (*xylE* under control of IGRIV') or pNGA8 (containing promoterless *xylE*). Activity of catechol 2,3-dioxygenase (C23DO) in the cell extract of *R. rhodochrous* ATCC 12674 (pNGA7) or

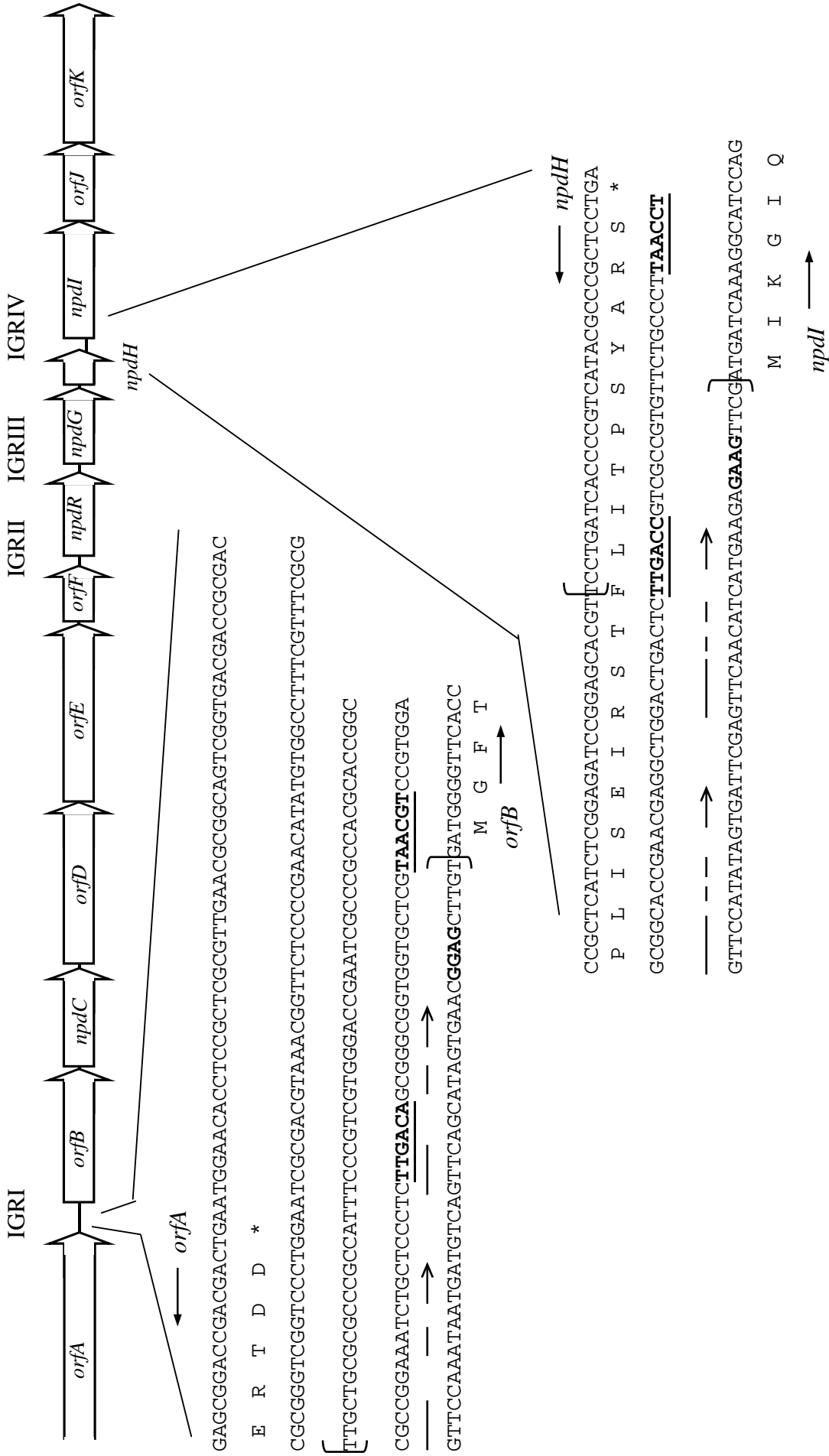

Fig.3. The *npd* gene cluster (Genbank accession number AF323606) showing intergenic regions. IGR I and IGR IV are enlarged. Direct repeats are indicated by arrows; - 35 and - 10 hexamers are indicated by bold type and underling; putative Shine-Dalgarno sequences are indicated by bold type. Brackets demarcate IGR I' and IGR IV', which were used for the experiments.

(pNGA9) was 1030 mU/mg or 1513 mU/mg respectively, while with cell extract of *R. rhodochrous* ATCC 12674 (pNGA8), it was only 20 mU/mg (Fig.4). Hence, the activity of C23DO was 50-fold or 70-fold higher under the control of IGRI' or IGRIV' compared to the promoterless *xylE* gene.

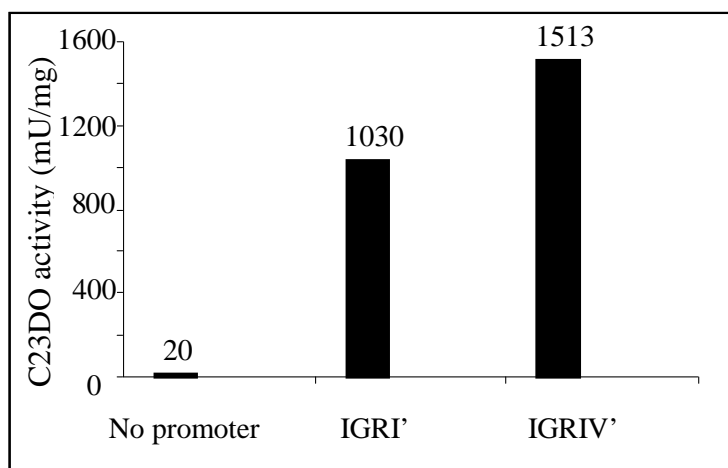

Fig.4. Expression of *xylE* gene under the control of IGRI' or IGRIV'. The cell extracts and enzyme assays were prepared as described in the Materials and Methods section. The values are the average value of three independent experiments.

3.2. Characterisation of *npdR* and the encoded repressor in *R. opacus* HL PM-1

3.2.1. Heterologous expression of *npdR* in *E. coli*

In order to study the function of NpdR, the *npdR* gene was expressed under the control of the T7 promoter in vector pET11a. The gene was amplified by PCR using primer Val-*npdR*-for and Bam-*npdR*-rev (Table 4, number 1, 2). The start codon of NpdR is GTG. In Val-*npdR*-for primer, the GTG start codon was replaced by ATG of the *NdeI* site. Bam-*npdR*-rev was introduced with *BamHI* site. The amplified DNA was digested with *NdeI* and *BamHI* and ligated into pET11a digested with the same restriction enzymes. The resulting plasmid pNGA1 was transformed into *E. coli* BL21 (DE3) (Fig.5A). For expression, *E. coli* BL21 (DE3)(pNGA1) was induced with IPTG for 4 h at 30 °C. SDS-PAGE analysis of cell extracts from *E. coli* BL21 (DE3)(pNGA1) showed the presence of a polypeptide band at about 26.8

kDa, which was absent from the cell extract of *E. coli* BL21 (DE3)(pET11a) (Fig.5B). The size of the protein coincided with the size of the translated sequence of *npdR*, 26867.82 Da.

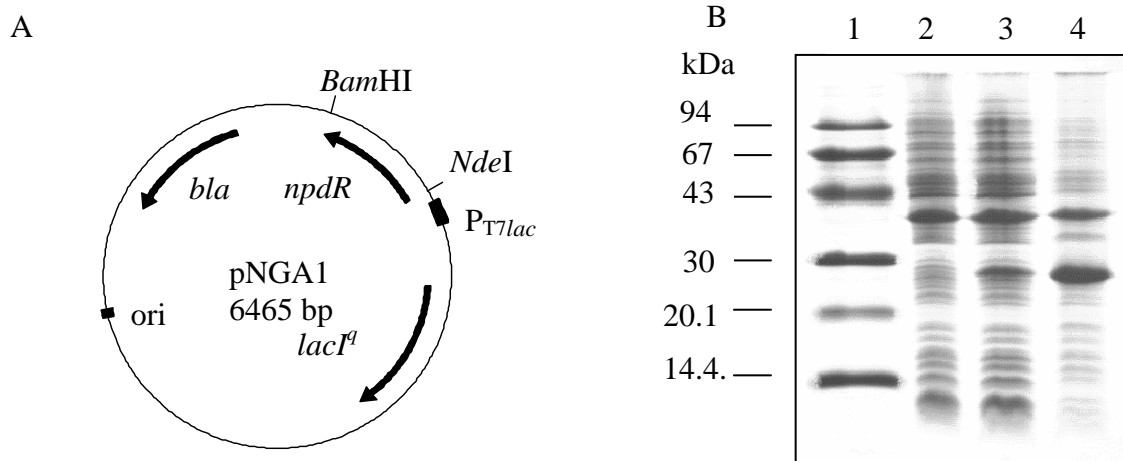

Fig.5A. Expression plasmid pNGA1. *npdR*: *npdR* gene; *bla*: β -lactamase gene; *lacI^q*: *lac* repressor. 5B. SDS-PAGE analysis of crude extract of *E. coli* BL21 (DE3)(pNGA1) or (pET11a). 1. Low molecular weight standard protein; 2. Cell lysate of *E. coli* BL21 (DE3)(pET11a); 3. Cell lysate of *E. coli* BL21 (DE3)(pNGA1); 4. Cell pellet of *E. coli* BL21 (DE3)(pNGA1). The cultures were induced with IPTG and the cells were lysed with the French press as described in Materials and Methods. The obtained crude extracts were ultra-centrifuged. The pellets and the supernatants (cell lysates) were separated on a 15 % (w/v) polyacrylamide gel.

3.2.2. Purification of NpdR from *E. coli*

In order to characterise NpdR, purification of the protein is necessary. Therefore, the *npdR* gene was amplified using the same two primers Val-*npdR*-for and Bam-*npdR*-rev as above (see 3.2.1). The gene was inserted into *Nde*I and *Bam*HI sites of pAC28 such that 6 histidine residues were fused to the amino terminal residue of the resulting protein. The *npdR* gene was expressed in *E. coli* BL21 (DE3)(pNGA5) (Fig.6A) by inducing the cells with IPTG as described above (see 3.2.1). NpdR was purified as a His-Tag fusion protein by Ni-NTA metal affinity chromatography. SDS-PAGE analysis of the purified fractions showed a single polypeptide band. The size of the purified fusion protein was about 28 kDa (Fig.6B).

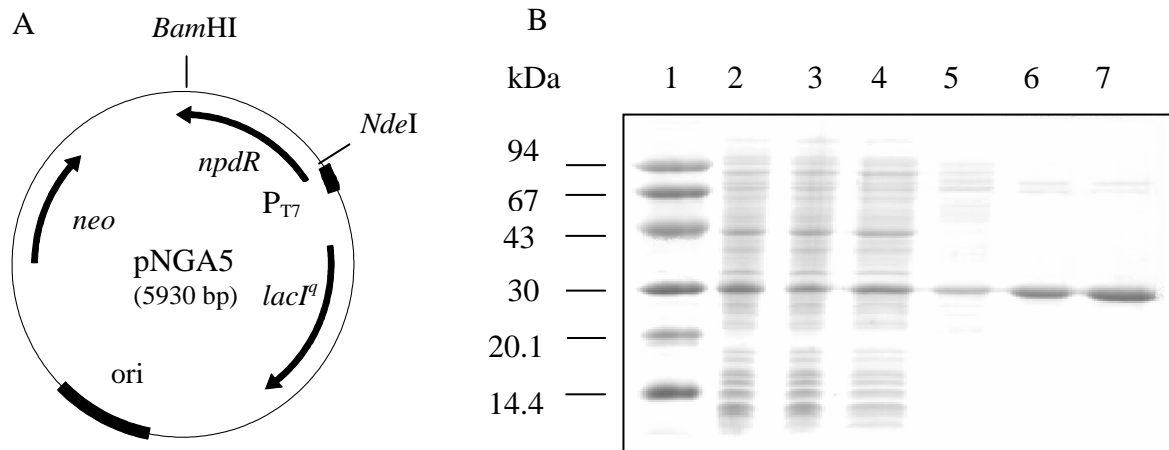

Fig.6A. Plasmid pNGA5. *npdR*: *npdR* gene; *lacI^q*: lac repressor gene; *neo*: kanamycin resistant gene; *P_{T7}*: phage T7 promoter. 6B. SDS-PAGE showing purification of NpdR-His from *E. coli* BL21 (DE3)(pNGA5). 1. Low molecular weight standard protein; 2. Cell lysate; 3. Fraction obtained after loading through the column; 4. Fraction obtained after washing with 5 mM imidazol; 5. Fraction obtained after washing with 25 mM imidazol; 6-7. Eluent obtained with 150 mM imidazol. The protein was purified according to the supplier.

3.2.3. Binding of NpdR to DNA regions within IGRI' and IGRIV'

Within the *npd* gene cluster, there were four intergenic regions IGRI, IGRII, IGRIII and IGRIV, but only in IGRI and IGRIV, putative promoter regions were discovered (see 3.1). To identify the DNA binding ability of NpdR, gel mobility shift assays (GMSAs) were performed for the crude extracts of *E. coli* BL21 (DE3)(pNGA1) containing the non-His tag NpdR and with DNA fragments of all four IGRs. IGRI', II, III or IGRIV' were amplified using primers GMSA1-for and GMSA1-rev (Table 4, number 3, 4), GMSA2-for and GMSA2-rev (Table 4, number 5, 6), GMSA3-for and GMSA3-rev (Table 4, number 7, 8), and GMSA4-for and GMSA4-rev (Table 4, number 9, 10) respectively. All primers were labeled with Cy5 at the 5' terminus. The labeled DNA fragments were incubated with the crude extracts. The GMSAs showed that the binding of NpdR to the DNA retarded mobility of the DNA in the gel forming complex 1 (C1). Hence, the expressed NpdR in the crude extract formed DNA-protein complexes with IGRI' and IGRIV' (Fig. 7, lane 3, 7), but not with IGRII or IGRIII (data not shown). This result coincided with the inability to detect putative promoter region in these DNA segments (see 3.1.1). Adding unlabeled IGRI' in 40-fold excess of the labeled DNA, prevented binding (lane 4). In addition, complex formation was not prevented in the presence of an arbitrary, unlabeled sequence (*npdH*) 40-fold in excess

(lane 5). The same results were observed for IGRIV' (data not shown). No DNA-protein complex formation was observed with cell extracts lacking NpdR from *E. coli* (DE3)(pET11) (lane 2). This indicated that NpdR bound specifically to only IGRI' and IGRIV'.

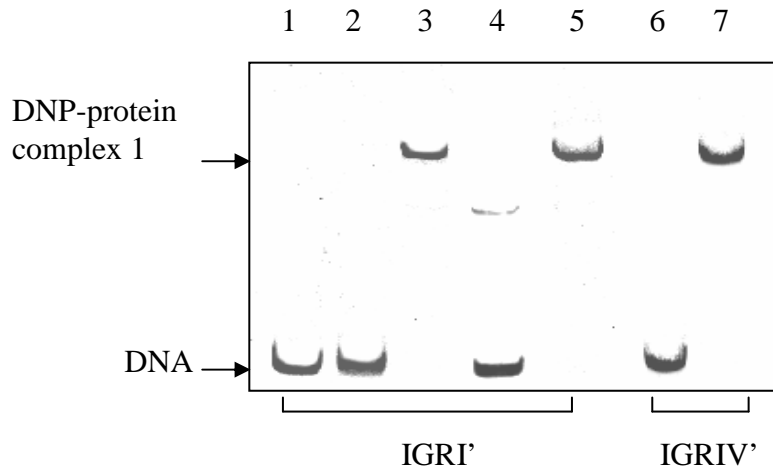

Fig.7. Gel mobility shift assay of crude extract from *E. coli* BL21 (DE3)(pNGA1) with IGRI' and IGRIV'. 1. IGRI'; 2. IGRI' plus crude extract from *E. coli* BL21 (DE3)(pET11a); 3-5. IGRI' plus crude extract from *E. coli* BL21 (DE3)(pNGA1); 4. IGRI' plus crude extract and 120 ng unlabeled IGRI'; 5. IGRI' plus crude extract and 120 ng unlabeled *npdH*; 6. IGRIV'; 7. IGRIV' plus crude extract from *E. coli* BL21 (DE3)(pNGA1). The cultures were induced with IPTG and lysed by sonication. 300 ng protein of the crude extracts were incubated with 3 ng labeled DNA fragments and analysed by native PAGE as described in Materials and Methods.

3.2.4. Binding of the purified His-tag fusion NpdR to IGRI' and IGRIV'

Crude extract containing NpdR lacking the His-tag (NpdR) caused a retardation in mobility of IGRI' and IGRIV' in the polyacrylamide gel (see 3.2.3). To show that the retardation is due to NpdR itself and to investigate precisely the interaction of NpdR with its specific operator region, the purified His-tag fusion NpdR (NpdR-His) was used for further GMSAs. NpdR-His formed complex 1(C1) and complex 2 (C2) with both IGRI' and IGRIV' (Fig.8). Hence, the His-tag fusion at the N terminus of NpdR did not affect the DNA binding ability of NpdR. At lower NpdR concentrations, both complexes were observed (A. lane , 3, 4, 5; B. lane 3). At higher NpdR concentrations (150-200 ng), only C1 was observed (A, B, lane 2). It suggests that NpdR may be a homodimeric protein.

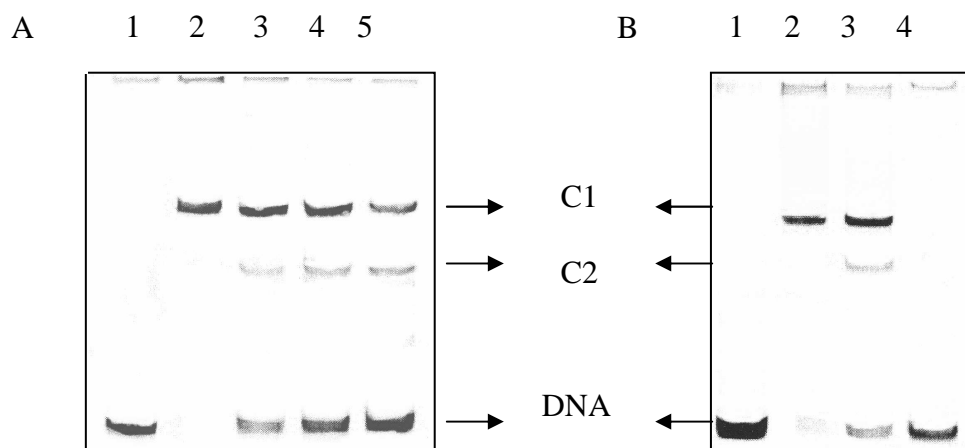

Fig.8. A. Gel mobility shift assay of NpdR-His with IGRI'. 1. IGRI' only; 2-5. IGRI' plus NpdR-His (150, 100, 50, 25 ng). B. Gel mobility shift assay of NpdR-His with IGRIV'. 1. IGRIV' only; 2-4. IGRIV' plus NpdR-His (200, 100, 25 ng). NpdR-His was incubated with 2-3 ng labeled DNA (for all lanes) and analysed by native PAGE as described in Materials and Methods.

3.2.5. Effect of DNP on DNA-NpdR complex formation

Since NpdR bound to IGRI' or IGRIV' containing promoter regions, this suggested that NpdR might control expression of the *npd* genes. DNP was proven before to be an inducer for the *npd* genes (Walters et al., 2001). Hence, DNP may have some effect on the binding of NpdR to the DNA regions. To identify the effect of DNP on NpdR-DNA interaction, DNP was added to the reaction mixtures. C2 was formed with both IGRI' (Fig. 9, lane 3-7) and IGRIV' (data not shown) in the presence of DNP. To show that C2 was specifically caused by DNP, gel retardation assays were performed with varying concentrations of DNP (0.001-10 mM) for both IGRI' and IGRIV'. C2 formation was reduced with decreasing DNP concentration (Fig. 9, data not shown for IGRIV'). At 10 mM DNP, C2 was the predominating complex (lane 3). At 0.001 mM DNP, C1 predominated (lane 7). This indicated that C2 was a true complex formed in the presence of DNP. To check if C2 formation is an effect caused by a specific interaction of DNP with NpdR and not by a chemical effect on any regulatory protein, the GMSA was performed with an unrelated regulatory protein from *Streptomyces*. No effect on the DNA-protein complex formation was observed (data not shown).

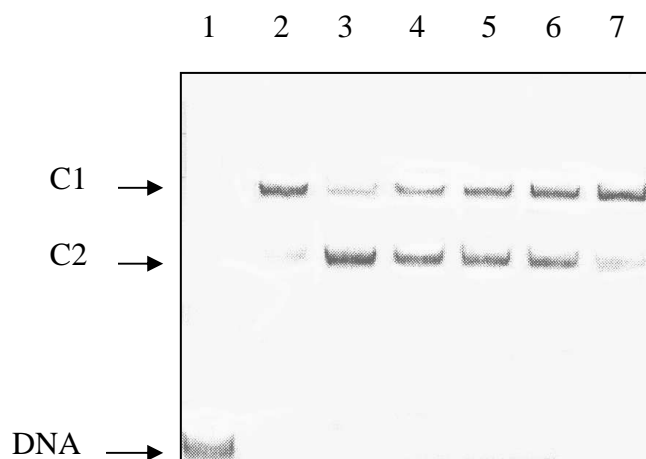

Fig.9. Gel mobility shift assay of IGRI' with NpdR-His in the presence of DNP. 1. DNA only; 2. DNA plus NpdR-His; 3-7. DNA plus NpdR-His and DNP (10, 1, 0.1, 0.01, 0.001 mM). The NpdR-His was purified as described in section 3.2. The GMSA reactions was performed with 200 ng NpdR-His plus 3 ng DNA for all lanes, and analysed by native PAGE as described in Materials and Methods.

3.2.6. Effect of analogous nitrophenol compounds on DNA-NpdR complex formation

Retardation assays were performed with other compounds for both IGRI' (Fig.10) and IGRIV' (data not shown for IGRIV'). C1 and C2 were formed in the presence of TNP (lane 8), 2-chloro-4,6-dinitrophenol (lane 6), 2-methyl-4,6-dinitrophenol (lane 7). 4-Nitrophenol (lane 3), 2,6-dinitrophenol (lane 5) and trinitrotoluene (TNT) (lane 9) did not affect binding of NpdR to either IGRI' or IGRIV'.

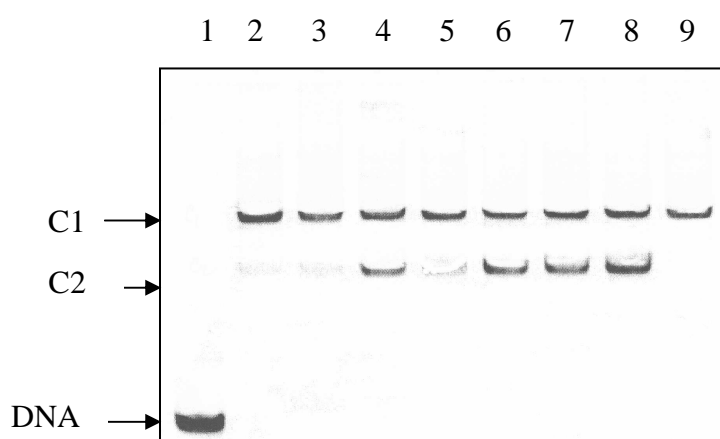

Fig.10. Gel mobility shift assay of IGRI' with NpdR-His in the presence of various effectors. 1. DNA; 2. DNA plus NpdR-His; 3-9. DNA plus NpdR-His and effector (3. 4-Nitrophenol; 4. DNP; 5. 2,6-dinitrophenol; 6. 2-chloro-4,6-dinitrophenol; 7. 2-methyl-4,6-dinitrophenol; 8. TNP; 9. TNT). The

NpdR-His was purified as described in section 3.2.2. The GMSA reactions were performed with 3 ng DNA and 200 ng NpdR-His plus 1 mM of effector for all lanes.

3.2.7. Identification of operator regions within IGRI' and IGRIV'

Sequence comparison of IGRI' and IGRIV' revealed sequences with high sequence similarity (Fig.3). Direct repeats were detected within these regions (Fig.3). This suggests that these regions may be responsible for interaction with NpdR. The region covering the direct repeats within IGRI' (GTGGAGTTCCAAATAATGATGTCAGTTCAGCATAGTGAACGGAGCT TGTG) was amplified by PCR using labeled primers Cy5-DR-for and GMSA1-rev (Table 4, number 27, 4). A gel retardation assay of the 52 bp DNA fragment showed that C1 and C2 were formed with NpdR-His (Fig.11, lane 5, 6). C1 formation decreased as the NpdR concentration was reduced (lane 4-6). By adding DNP, the formation of C1 or C2 was prevented and free DNA was visible. (lane 1-2). The results is complementary to all observations before (see 3.2.4 and 3.2.5), and it shows that binding takes place in the absence of DNP, whereas in the presence of DNP binding affinity of NpdR to the DNA decreases.

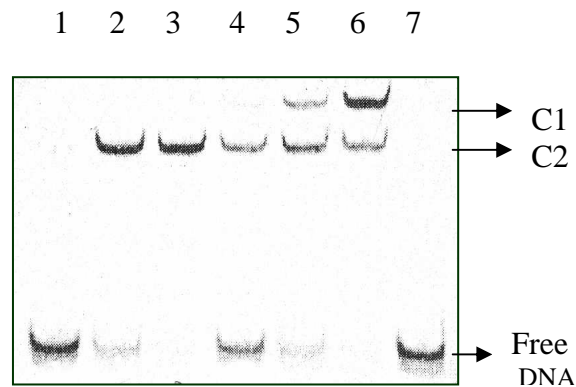

Fig.11. Gel mobility shift assay showing the binding of NpdR-His to 52 bp DNA fragment from IGRI' in the presence of DNP. 1-3. DNA plus NpdR (100, 200, 300 ng) and DNP; 4-6. DNA plus NpdR (100, 200, 300 ng); 7. DNA only. The His-tag NpdR was purified as described in section 3.2. His-tag NpdR was incubated with 0.7 ng DNA in the presence of 1 mM DNP, and analysed by native PAGE as described in Materials and Methods.

3.2.8. Creating an unmarked *npdR* deletion in *R. opacus* HL PM-1

To identify the function of NpdR, a deletion mutant for *npdR* was constructed. *npdR* was deleted at nucleotides 317-526. The 3' end and 5' end flanking regions of the deletion were amplified by PCR using primers: EcoRI-KO, KpnI 1-rev and KpnI 2-for, BamHI-KO respectively (Table 4, number 15-18). The PCR fragments were digested with *KpnI* and ligated, creating 2.2 kb fragment with a deletion of 210 bp in *npdR*. The ligated fragment was restricted with *EcoRI* and *BamHI* and ligated into the *EcoRI* and *BamHI* sites of pK18*mobsacB* to produce pNGA20. *E. coli* S17.1 was transformed with pNGA20 and then conjugated into *R. opacus* HL PM-1 (Fig.12A). Kanamycin was used for selection of the single cross-over event. Gene replacement was achieved by overnight growth of the single cross-strain ND13 under non-selective conditions and subsequently plating on selective medium containing 10 % (w/v) sucrose.

Colony PCR with Val-*npdR*-for and Bam-*npdR*-rev primers (Table 4, number 1, 2) on Suc^r colonies resulted in PCR products with fragment sizes of 546 bp, 210 bp shorter compared to the wild-type *npdR* (data not shown). It suggested that the Suc^r colonies contained deleted *npdR* instead of the wild-type gene. Genotypes of the mutant strains were analysed by Southern hybridisation: chromosomal DNA of *R. opacus* ND1 and *R. opacus* ND13 were digested with *EcoRI* and *BamHI* and hybridised with labeled deleted *npdR* (Fig.12B). The wild-type (lane 2) showed a single hybridisation signal of approximately 2.8 kb. The transconjugant ND13 (lane 4) showed two hybridisation signals of 2.8 kb and 2.2 kb. A single fragment of 2.6 kb was observed with the deletion mutant ND1 (lane 3). The hybridisation results coincided with the molecular organisation of *npdR* in the wild-type and mutant strains respectively (Fig.12A).

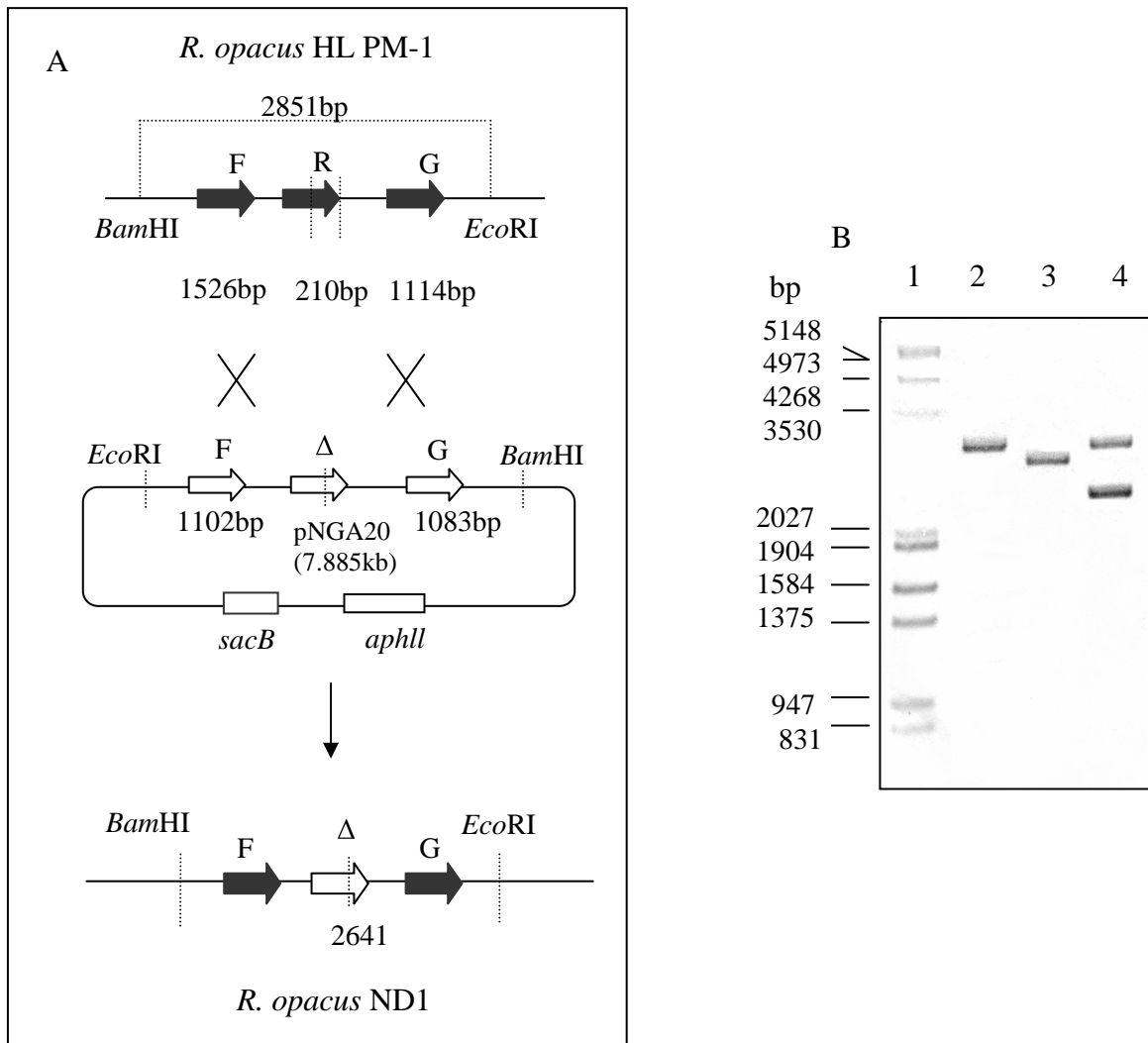

Fig.12A. Schematic overview of the molecular organisation of the region containing *npdR* in wild-type *R. opacus* HL PM-1 and in deletion mutant strain *R. opacus* ND1. **B.** Southern analysis of *R. opacus* chromosomal DNA digested with *Eco*RI and *Bam*HI and hybridised with deleted *npdR* gene. 1. λ -DNA digested with *Eco*RI and *Hind*III marker; 2. Wild-type HL PM-1; 3. Strain ND1; 4. Strain ND13 (single cross-over mutant). Total DNA of *R. opacus* strains was isolated and digested with *Eco*RI and *Hind*III. The digested DNA was separated on a 0.8 % (w/v) agarose gel and then transferred onto a nylon membrane. The membrane was hybridised with the deleted form of the *npdR* gene and detection was following the instructions from Roche.

3.2.9. Characterisation of *npdR* deletion mutant

3.2.9.1. Expression of *npdC* or *npdI* in the mutant *R. opacus* ND1

To determine if *npdR* is an activator or a repressor controlling expression of the *npd* genes, the HTI (NpdC) or HTII (NpdI) activities were measured in the mutant strain *R. opacus* ND1 to see whether a non-functional NpdR affects the expression levels of *npdC* and *npdI* or not. The wild-type *R. opacus* HL PM-1 and the mutant *R. opacus* ND1 were cultured in minimal media and induced with DNP. Cell extracts were prepared and enzyme assays were performed for detecting the HTII (conversion of TNP to H⁻TNP) and the HTI (conversion of H⁻TNP to 2H⁻TNP) (Table 5). Cell extracts from DNP-induced cultures of strain HL PM-1 exhibited approximately 50 to 60-fold greater activities for HTII or for HTI (385 or 78 mU/mg, respectively) compared to non-induced cultures (8.3 or 1.35 mU/mg, respectively). Cell extracts from induced cultures and non-induced cultures of the mutant strain ND1 showed very similar activities for HTII (1136 and 1261 mU/mg, respectively) or for HTI (222 and 223 mU/mg), irrespective of whether they had been induced or not. This shows that expression of *npdI* or *npdC* was constitutive in the deletion mutant. Further, it demonstrates that NpdR represses the expression of *npdI* and *npdC* in *R. opacus* HL PM-1.

Table 5. Specific activities of the HTII and the HTI in *R. opacus* HL PM-1 and *R. opacus* ND1

Bacterium	Specific activity (mU/mg cell extract)	
	TNP	H ⁻ TNP
<i>R. opacus</i> HL PM-1 Not induced	8.3 ± 2.0	1.35 ± 1.7
<i>R. opacus</i> HL PM-1 Induced with 0.5 mM DNP	385 ± 5.6	78 ± 7.0
<i>R. opacus</i> ND1 Not induced	1261 ± 267.2	223 ± 4.2
<i>R. opacus</i> ND1 Induced with 0.5 mM DNP	1136 ± 90.5	222 ± 15.5

The values are the means of two independent experiments, each done in triplicate.

3.2.9.2. Conversion of DNP or TNP by resting cells of *R. opacus* ND1

To confirm that NpdR is a repressor and the deletion mutant strain *R. opacus* ND1 expressed *npdC* and *npdI* as well as other *npd* genes constitutively, resting cells of the mutant ND1 was performed with on DNP or TNP as substrate (Fig.13).

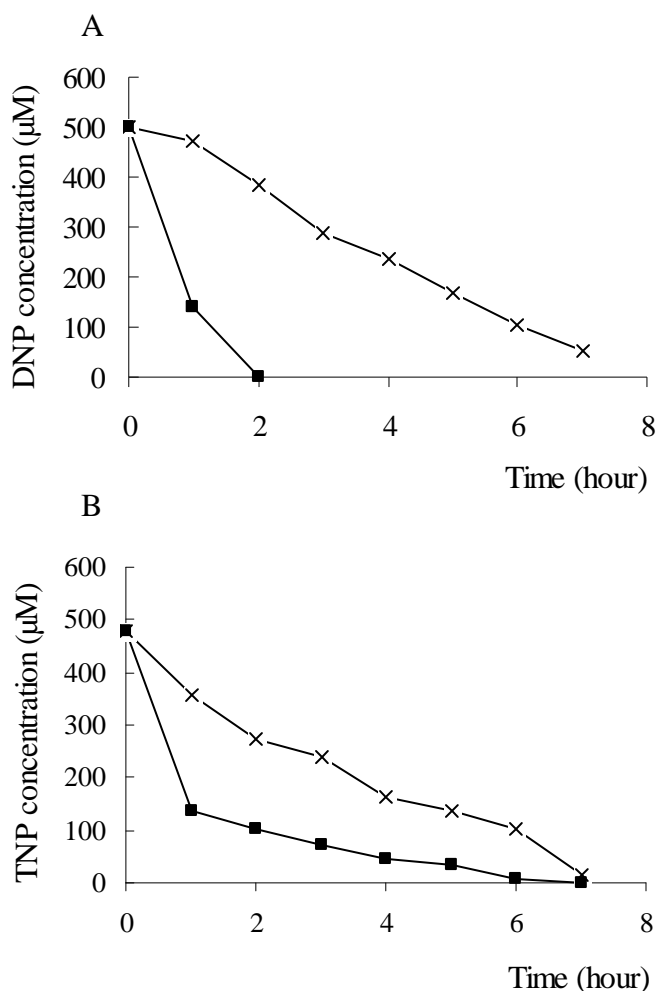

Fig.13. Transformation of DNP (A) or TNP (B) by resting cells of *R. opacus* HL PM-1 (x) and *R. opacus* ND1 (■). The cultures were harvested at the mid-log phase and resuspended in $\text{KH}_2\text{PO}_4/\text{K}_2\text{HPO}_4$ buffer (50 mM, pH 7.5) supplemented with 0.5 mM DNP or TNP. $\text{OD}_{600\text{nm}}$ of the cell suspensions after resuspension was 1.7-1.8. The samples were collected at relevant time intervals and analysed by HPLC as described in Materials and Methods. The values are the average values of two independent experiments.

The strain ND1 transformed DNP or TNP to the H-DNP or H-TNP much faster than the wild-type HL PM-1 (data not shown). The mutant cells converted DNP completely after 2 h,

whereas the wild-type cells converted DNP within 7 h. (Fig.13A). TNP was converted within 6 h by the mutant cells compared to 7 h by the wild-type cells (Fig.13B). Within the first hour, the concentration of DNP and TNP decreased significantly while incubating with resting cells of the mutant strain but remained almost unchanged with the cells of the wild-type strain. These results are due to the existence of fully active enzymes as a result of constitutive expression of the *npd* genes in the mutant strain.

3.2.10. Effect of NpdR on gene expression from IGRI' or IGRIV'

To show directly that NpdR affects expression of the *npd* genes from IGRI' or IGRIV', pNGA7 (expressing *xylE* from IGRI') or pNGA9 (expressing *xylE* from IGRIV') (see 3.1.2) were each transformed into *R. opacus* HL PM-1 or *R. opacus* ND1. Cell extracts from DNP-induced cultures of *R. opacus* HL PM-1 (pNGA7) or *R. opacus* HL PM-1 (pNGA9) possessed catechol 2,3-dioxygenase (C23DO) activities of about 1254 or 1827 mU/mg protein respectively (Table 6). Cell extracts of non-induced cultures of *R. opacus* HL PM-1 (pNGA7) or *R. opacus* HL PM-1 (pNGA9) possessed activities 3-fold lower compared to those of the induced cultures (about 444 or 616 mU/mg respectively). Cell extracts from induced or non-induced cultures of *R. opacus* ND1 (pNGA7) possessed comparable activities 1890 or 2000 mU/mg. Control samples of strain *R. opacus* HL PM-1 (pNGA8) (promoterless *xylE* in pK4) exhibited no difference for C23DO activities, irrespective of whether they had been induced or not (84 and 80 mU/mg). The results showed that *xylE* expression is induced by DNP when under the control of IGRI' or IGRIV' in the wild-type strain, and the expression was constitutive in the deletion mutant for *npdR*. A possible reason for the low level of induction is that not enough NpdR is expressed from strain HL PM-1 to saturate the binding sites in IGRI' and IGRIV' to completely repress *xylE* expression from pNGA7 or pNGA9.

Table 6. C23DO activity in *R. opacus* HL PM-1 and *R. opacus* ND1 containing pNGA7 or pNGA9

Bacterium	C23DO activity (mU/mg cell extract)
<i>R. opacus</i> HL PM-1 (pNGA7) Not induced	444 ± 27
<i>R. opacus</i> HL PM-1 (pNGA7) Induced with 0.5 mM DNP	1254 ± 59
<i>R. opacus</i> ND1 (pNGA7) Not induced	1890 ± 84
<i>R. opacus</i> ND1 (pNGA7) Induced with 0.5 mM DNP	2041 ± 102
<i>R. opacus</i> HL PM-1 (pNGA9) Not induced	616 ± 33
<i>R. opacus</i> HL PM-1 (pNGA9) Induced with 0.5 mM DNP	1827 ± 98

pNGA7 contains *xylE* under the control of IGR1'; pNGA9 contains *xylE* under the control of IGRIV'. The values are the means of two independent experiments, each done in triplicate.

3.3. Determination of a putative promoter region in IGRII

To elucidate whether the upstream sequence of *npdR* contains a promoter region controlling expression of *npdR* or not, the intergenic region between *orfF* and *npdR* (IGRII) was amplified using EcoRI-IGRII and KpnI-IGRII primers (Table 4, number 19, 20) and cloned upstream of *xylE* gene in pK4, resulting in pNGA27. pNGA8 (containing promoterless *xylE*) or pNGA27 (*xylE* under control of IGRII) was transformed into *R. rhodochrous* ATCC 12674. There was no difference between C23DO activities in the cell extracts of *R. rhodochrous* ATCC 12674 (pNGA27) and those of *R. rhodochrous* ATCC 12674 (pNGA8), 83.5mU/mg (Fig.14). This result may be due to the absence of a promoter in IGRII or due to the lack of a regulatory factor necessary for the expression from the putative promoter. To answer the question if there is any other activator in the wild-type strain needed to drive the expression of *xylE* gene from IGRII, pNGA27 or pNGA8 was transformed back into the wild-type *R. opacus* HL PM-1. Cell extracts derived from non-induced cultures of *R. opacus* HL PM-1 (pNGA27) exhibited approximately 6-fold higher C23DO activities (536.5 mU/mg)

than those of *R. opacus* HL PM-1 (pNGA8) (88.5 mU/mg). DNP-induced cell extracts of *R. opacus* HL PM-1 (pNGA27) showed comparable activities to the non-induced ones (Fig.14) The result suggests that IGRII may contain a weak promoter region and an activator may be needed for expression from this promoter. Further, DNP may not induce the expression of *xylE* from IGRII.

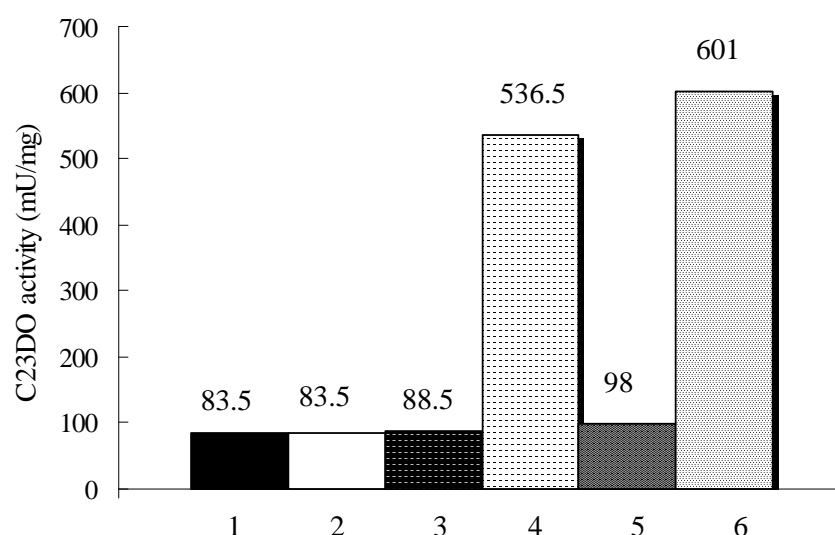

Fig.14. Expression of *xylE* under the control of IGRII in *R. rhodochrous* ATCC 12674 (1-2) or in *R. opacus* HL PM-1 (3-6). 1. Not induced *R. rhodochrous* ATCC 12674 (pNGA8); 2. Not induced *R. rhodochrous* ATCC 12674 (pNGA27); 3. Not induced *R. opacus* HL PM-1 (pNGA8); 4. Not induced *R. opacus* HL PM-1 (pNGA27); 5. Induced *R. opacus* HL PM-1 (pNGA8); 6. Induced *R. opacus* HL PM-1 (pNGA27); The cell extracts and enzyme assays were prepared as described in the Materials and Methods. pNGA8 contains promoterless *xylE*. pNGA27 contains *xylE* under the control of IGRII. The values are the average values of two independent experiments.

3.4. Alternative inducers of TNP degradation

3.4.1. Induction of *npdC* at the transcriptional level

DNP is known to be an inducer that switches on the expression of the TNP genes (*npdC*, *npdG* and *npdI*) in *R. opacus* HL PM-1 (Walters et al., 2001). Gel retardation assays showed that the analogous compounds TNP, 2-chloro-4,6-dinitrophenol and 2-methyl-4,6-dinitrophenol caused changes in the formation of the DNA-NpdR complex (see 3.2.6). It suggested that these compounds may also serve as inducers of TNP degradation. To show that the analogous compounds induce the expression of *npd* genes at the transcriptional level, total RNA of *R. opacus* HL PM-1 was isolated after 2 h of induction and hybridised with a RNA

probe. The probe used corresponded to the full-length transcribed *npdC*. Abundance of the mRNA of *npdC* was much higher in total RNA of cultures induced with DNP, TNP, 2-chlor-4,6-dinitrophenol or 2-methyl-4,6-dinitrophenol compared to the non-induced one (Fig.15). Almost no mRNA of *npdC* was detected in total RNA of culture induced with 4-nitrobenzoate or non-induced culture.

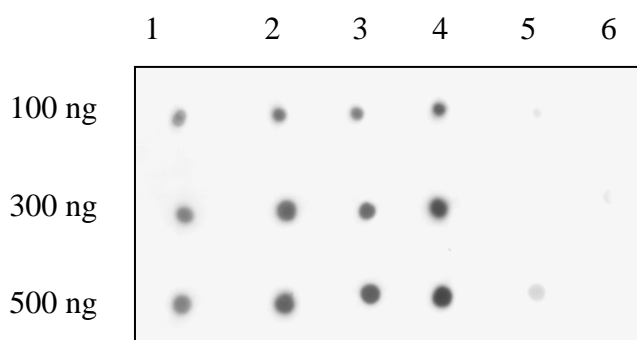

Fig.15. Northern dot blot analysis of total RNA from *R. opacus* HL PM-1 after inducing the cultures with various compounds. 1. DNP; 2. TNP; 3. 2-chlor-4,6-dinitrophenol; 4. 2-methyl-4,6-dinitrophenol; 5. 4-nitrobenzoate (negative control); 6. No induction. The cultures were grown to the mid-log phase and induced with 0.5 mM of each nitrophenol. Total RNAs were isolated and spotted onto a nylon membrane as described in Materials and Methods. The *npdC* gene was labeled by *in vitro* transcription using the Dig Northern Starter Kit to obtain the RNA probe. Hybridisation was performed at 68 ° C following the instructions of the supplier.

3.4.2. Induction of *npdC* or *npdI* in *R. opacus* HL PM-1 at the translational level

To confirm that the above tested compounds indeed induced the expression of the *npd* genes at the translational level, enzyme assays of HTI (encoded by *npdC*) or HTII (encoded by *npdI*) were performed with crude extracts of *R. opacus* HL PM-1 after inducing the cultures with 0.5 mM of the analogous compounds (Table 7). Crude extracts of *R. opacus* HL PM-1 cultures induced with TNP, 2-chloro-4,6-dinitrophenol or 2-methyl-4,6-dinitrophenol, showed 37-43 fold higher HTII activities (571 mU/mg for 2-methyl-4,6-dinitrophenol; 612.5 mU/mg for 2-chloro-4,6-dinitrophenol or 660 mU/mg for TNP) compared to the non-induced cultures (15.5 mU/mg). Crude extracts of induced cultures of *R. opacus* HL PM-1 also possessed 51-76 fold higher HTI activities compared to the non-induced cultures. Induction levels were similar for all three inducers. Neither HTI nor HTII activity increased when the cultures were

induced with 4-Nitrophenol. These results coincide with the above result (see 3.4.1) and with GMSA that TNP, 2-chloro-4,6-dinitrophenol, 2-methyl-4,6-dinitrophenol but not 4-Nitrophenol reduced the affinity of NpdR binding to IGRI' or IGRIV' (see 3.2.6).

Table 7. Specific activity of HTII or HTI in *R. opacus* HL PM-1 after treatment of the cultures with various nitrophenols

Bacterium	Specific activity (mU/mg cell extract)	
	TNP	H-TNP
<i>R. opacus</i> HL PM-1 Not induced	15.5 ± 2.5	1.8 ± 0.8
<i>R. opacus</i> HL PM-1 Induced with 0.5 mM TNP	660 ± 7	138 ± 8
<i>R. opacus</i> HL PM-1 Induced with 0.5 mM 2-chloro-4,6-dinitrophenol	612.5 ± 15.5	92.5 ± 3.5
<i>R. opacus</i> HL PM-1 Induced with 0,5 mM 2-methyl-4,6-dinitrophenol	571 ± 46	93 ± 5
<i>R. opacus</i> HL PM-1 Induced with 0.5 mM 4-Nitrophenol	45 ± 5	4 ± 1

The values are the means of two independent experiments, each done in triplicate.

3.4.3. Conversion of TNP by resting cells of *R. opacus* HL PM-1 after inducing the cultures with various inducers

To compare TNP turnover of induced cultures with non-induced cultures of *R. opacus* HL PM-1, the cultures were induced with DNP, TNP, 2-chlor-4,6-dinitrophenol or 2-methyl-4,6-dinitrophenol as described before, then resting cells were exposed to TNP (Fig.16).

Non-induced cells converted TNP very slowly, which disappeared only after 13 h. Resting cells, induced with DNP, TNP, 2-chlor-4,6-dinitrophenol or 2-methyl-4,6-dinitrophenol converted TNP to H-TNP completely within 1,5-2 h with the same rates (Fig.16A). Formation of H-TNP was slower for the non-induced cells compared to the induced cells. Resting cells of induced cultures formed H-TNP reaching highest concentrations at 2 h. H-TNP disappeared completely after 3-4 h. The H-TNP conversion rate of the four induced

resting cells were also comparable (Fig.16B). This result once more confirmed that DNP, TNP, 2-chlor-4,6-dinitrophenol or 2-methyl-4,6-dinitrophenol induced the expression of the TNP genes.

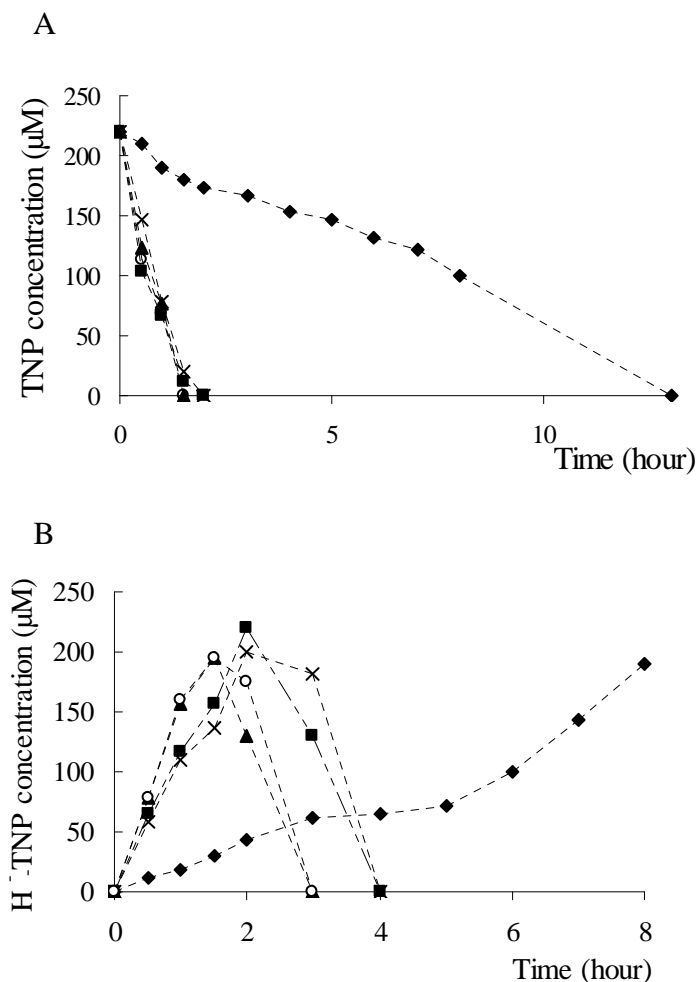

Fig.16. Conversion of TNP by resting cells of *R. opacus* HL PM-1 after inducing the cultures with various inducers. A. Reduction of TNP concentration. B. Formation of H-TNP. (◆) Not induced. (■) Induced with TNP. (▲) Induced with DNP. (×) Induced with 2-chlor-4,6-dinitrophenol. (○) Induced with 2-methyl-4,6-dinitrophenol. The cultures were induced with 0.5 mM of each nitrophenol for 2 h and then harvested. The cells were resuspended in $\text{KH}_2\text{PO}_4/\text{K}_2\text{HPO}_4$ buffer (50 mM, pH 7.5) supplemented with 0.22 mM TNP. $\text{OD}_{600\text{nm}}$ of the cell suspension was 1.5-2.0. The samples were collected at relevant time intervals and analysed by HPLC as described in Materials and Methods. The values are the average values of two independent experiments.

3.4.4. Inducibility of *npd* genes in other DNP degrading strains

As shown in section 3.2, NpdR repressed expression of the *npd* genes by binding to IGRI' or IGRIV'. The affinity of NpdR for IGRI' or IGRIV' was reduced in the presence of DNP, TNP, 2-chlor-4,6-dinitrophenol, and 2-methyl-4,6-dinitrophenol. Those analogous compounds were shown to induce the expression of *npdC* and *npdI* (see 3.4.1-3.4.3). So far, several further DNP-degrading strains have been identified: *N. simplex* FJ2-1A is able to utilise DNP and TNP as sole of nitrogen source (see 1.3); *Rhodococcus* sp. strain DNP 14-5, *Rhodococcus* sp. strain HL 24-1, *Rhodococcus* sp. strain CB 24-1 were shown to be able to grow on DNP as sole nitrogen source (Heiss et al., 2003). Pairwise alignments performed with the *npdG* and *npdI* from these strains and *npdG* and *npdI* from the reference strain *R. opacus* HL PM-1 showed high sequence identities (86 to 99 %). NpdG and NpdI were also demonstrated to have the same function as the homologous proteins in *R. opacus* HL PM-1 (Heiss et al., 2003). For improved understanding of TNP degradation we want to determine the inducibility of DNP/TNP degradation in these DNP-degraders.

Enzyme assays for HTII or HTI activities were performed with *N. simplex* FJ2-1A, *Rhodococcus* sp. strain DNP 14-5, *Rhodococcus* sp. strain HL 24-1 and *Rhodococcus* sp. strain CB 24-1 (Fig.17). Cell extract of *N. simplex* FJ2-1A exhibited similar activities for HTII (140,5 or 157 mU/mg) (Fig.17A) or for HTI (243 or 203 mU/mg) (Fig.17B), irrespective of whether the cultures had been induced or not. The result coincides with the observations before that TNP degradation potential of *N. simplex* FJ2-1A is constitutive (Russ et al. unpublished results). The enzyme activities in all other *R. opacus* strains were similar to those in *R. opacus* HL PM-1. TNP degradation potential was increased after exposure to DNP: cell extracts from induced cultures of DNP 14-5, HL 24-1 or CB 24-1 possessed 16 to 38-fold higher activities for HTII (Fig.17A) and 4.6 to 9.6-fold higher activities for HTI compared to the non-induced cultures (Fig.17B). This result suggests that the transcriptional regulation mechanism of TNP metabolism in these *R. opacus* strains may be similar to the one in *R. opacus* HL PM-1. Hybridisation analysis of total DNA from these *R. opacus* strains showed hybridisation signals with *npdR* from strain HL PM-1 (N. Trachtmann, G. Heiss unpublished data). It means that *R. opacus* DNP14-5, *R. opacus* HL24-1 and *R. opacus* CB24-1 may contain a gene with the sequence similar to the sequence of *npdR* from *R. opacus* HL PM-1.

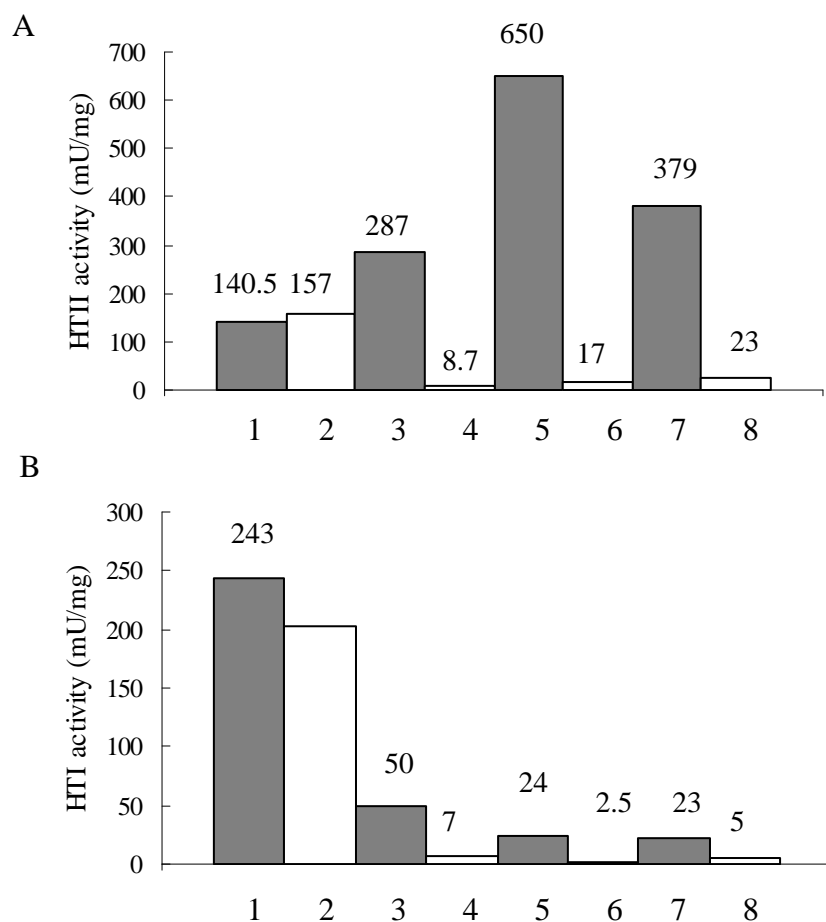

Fig.17. HTII (A) or HTI (B) activities of different DNP-degrading strains after inducing the cultures with DNP. ■ Induced culture. □ Non-induced culture. 1-2. *N. simplex* FJ2-1A. 3-4. *R. opacus* DNP14-5. 5-6. *R. opacus* HL24-1. 7-8. *R. opacus* CB24-1. The cultures were grown to the mid-log phase and induced with 0.5 mM DNP for 2 h. The harvested cells were lysed with the French press. HTI or HTII enzymes assays were performed as described in Materials and Methods.

3.5. Identification of the function of *orfA1* and *orfA2* in TNP metabolism

Comparing *orfA* (Fig.3) to sequences in the database revealed that it comprise two open reading frames: *orfA1* and *orfA2*, which may code for two putative transcriptional regulators of a two-component regulatory system (Fig.18). The product of *orfA1* may contain a helix-turn-helix DNA binding motif. Its sequence showed 48 % sequence similarity to a nitrate/nitrite response regulator of *E. coli* and 43 % sequence similarity to a hypothetical transcriptional regulator of *Mycobacterium bovis* (Genbank, NCBI). *orfA2* seemed to be missing the 5' end sequence of the corresponding gene. The 3' end showed similarities to a

putative serine/threonine protein kinase (Genbank, NCBI). The question to be answered was whether this two-component regulatory system plays a role in TNP metabolism.

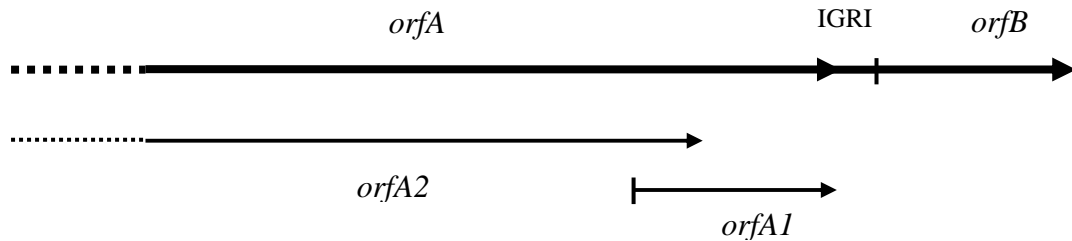

Fig.18. Location of *orfA1* and *orfA2* in the *npd* gene cluster. Arrows represent the open reading frames (not drawn to scale). Dashed line represents the missing sequence. IGRI is the intergenic region I.

3.5.1. Cloning and sequencing the 5' end of *orfA2*

Sequence comparisons of *orfA2* to the sequences in the databases (Genbank, NCBI) indicated that *orfA2* lacked about 500 amino acids at the N terminus of the corresponding protein. To search for the missing part of *orfA2*, 456 bp from the 5' end of the known sequence of *orfA2* was amplified using the OrfA2probe-for and OrfA2probe-rev primers (Table 4, number 28, 29). The PCR product was used as the probe for hybridisation with digested chromosomal DNA of *R. opacus* HL PM-1 (Fig.19A.). The probe hybridised with the chromosomal DNA of *R. opacus* HL PM-1 digested with *EcoRI* and *SacI*, showing a signal at 2.5 kb. The 2.5 kb DNA fragment containing a pool of *EcoRI-SacI* fragments was cut out of the gel and cloned into the *EcoRI* and *SacI* sites of pBluescript II SK(+). Colony hybridisation of *E. coli* DH5 α containing the pool of recombinant plasmids against the *orfA2* probe, was used to screen for the clones with the right plasmid inserts. The recombinant plasmid contains the right insert is named pNGA34 (Fig.19B). The 2.5 kb insert was sequenced from the T3 and T7 primer binding sites on pBluescript II SK(+). The sequence of *orfA2* revealed a complete open reading frame of 2895 bp with 56 % sequence similarity to a serine/threonine protein kinase PknK of *Mycobacterium tuberculosis* (Genbank, NCBI) (see Fig.20).

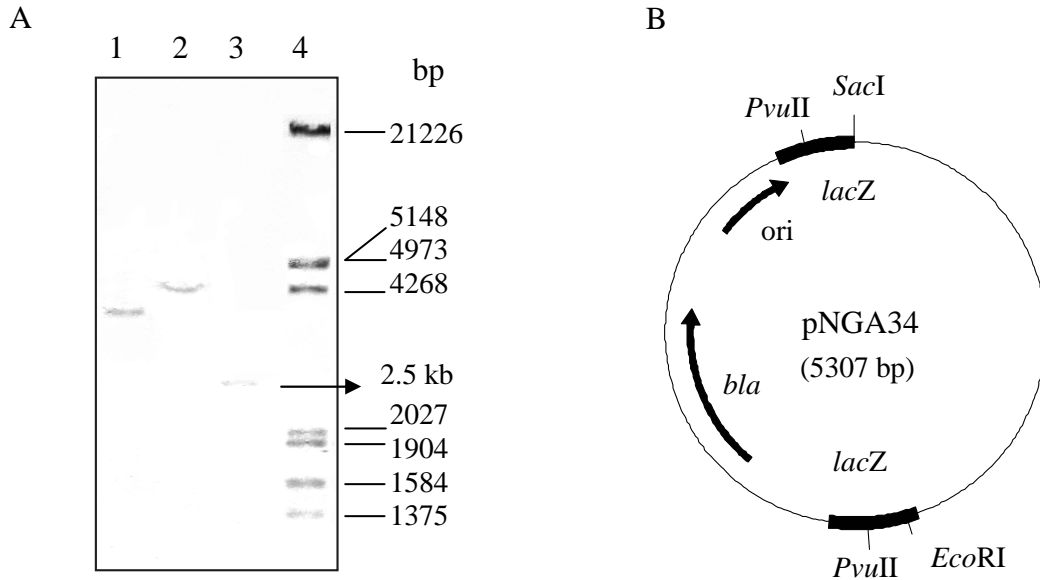

Fig.19. A. Southern hybridisation of digested chromosomal DNA from *R. opacus* HL PM-1 with the *orfA2* probe. 1. DNA digested with *EcoRI-HindIII*; 2. DNA digested with *EcoRI-SalI*; 3. DNA digested with *EcoRI-SacI*; 4. λ -DNA digested *EcoRI-HindIII* marker. Total DNA of *R. opacus* HL PM-1 was isolated and digested with the relevant enzymes. The digested DNA was separated on a 0.8 % (w/v) agarose gel and then transferred to a nylon membrane. The membrane was hybridised with 456 bp, 5' end of the known sequence of *orfA2* and detected following the instructions from Roche.

B. Plasmid pNGA34 contains 2.5 kb of the 5' end of *orfA2* in *EcoRI* and *SacI* sites. *bla*: β -lactamase gene. *lacZ*: β -galactosidase gene.

→ *orfA2* start

...CGGTGTGCGGGGAACCACGAGCCGACGGGGT GAGTAGACCGTCCG**ATGGG**TGAAGATG
ATCCGTGCGATACGCAGCGGTACGTCGTCCCCGACGTGGCTGCGGAGTTGAGCGAAGCTGGT
TTCGACGATGCCAGGAGATCGGGCGCGGCGGTTTCGGCGTGGTCTACCGCTGCACGCAGGC
GGAGCTGGATCGCACGGTGGCGGTGAAGGTA CTACCGT CGAACTCGACGAGGAGAACCGGG
CTCGGTTCTTCCGGGAGCAGCGGGCGATGGGGCGGCTCACCGGGCACCCGAACATCGTGGGC
GTCCTGCAGGTCGGTGCCACCGACAGCGGACTTCCGTACATCGTGATGCCCTACCACTCGCA
GGTTTCGCTCGACGTGCGGATCCGCCGTCGCGGTCCGCTGCCGGTGGAGAAGGCGCTGCGCC
TCGGGGTGAAGATCGCGGGTGCGGTGGAGTCGGCGCACCGGCTCGGCATCCTGCATCGCGAC
GTCAAACCCGCGAACATCCTGCTCACCGATTACGGAGAGCCGGCGTTGACCGATTTTCGGCAT
CGCGCACGTCAGCGGGGGCTTCGAGACCGCCACCGGGACCGTGCAGGGATCGCCGGCGTACA
CCGCGCCGGAGGTGCTCGGAGGTGACTCACCGACCCCGCCCGACGTCTACGGCCTCGGT
GCCACCTTGTTCAGTGCTCTCACCGCCATGCCGCGTTTCGAACGTCGCAGCGGCCGAACAGGT

CGTCGCGCAGTTCCTGCGGATCACCACGCAAGAGGTGCCCGATCTGCGTGACCACGGGATCC
 CGGACGATGTGTCCGAGGCGATCGCGCGGGCGATGTCTCGAACCCCGGATCAGCGACCGGCC
 ACCGCCGCCGACTTCGGGGAGGAACTGCGACGGCTCCAACACGATCATGGCTTTCCGGTTCGA
 CGAGATGGCCCTGCACACCGTCCCTGGGTGGCAAGCGGCGACGCACAACCAGAGTCCGGCC
 GACCTCGATCGGCGGTGTCTCCGCGCTGGGCGCGACGGGGCGTCTTCCCCTGGAAGTACC
 AGTTTCGTGCGCCGCCGACACGAACTCACCGAGGCGAAGAATCTGTTGGCCGGGTCCCGACT
 GGTGACGTTGATCGGGATCGGGGTGTGGGCAAGACGCGGCTGGCGATGCGGGTGGCGGCAA
 GTGTCCAGCGCGACTACGCCGACGGTGTGCGGCTTGTTCGGATTGGGTGAACTGCGCGACGAG
 TCGTCGCTCGTCGACGCAGTGGCCGGCGCACTGGGATTGCGAGACCACTCGGCGAGGCCGTT
 GCGTGAGGTCTGATCGAGTTTCTCGTGCCGCGGAACTGCTGTTGGTCTCGACAAGTGC
 AGCACATGGTGGACGCAGCAGCGGAACTGGCCGAGACCCTGTTACGGGTGTGCCCGGGCCTG
 CGGATTCTGGCCACCAGCCGCGAACCCTGGTCATCGGTGGGGAAGCAGTGTGCGGGTCCC
 CCCGCTGGCTGTCCCGGATCCGGAACGGCGGCCCTCCTTGCGAACGTTGTCCCGATACGATG
 CCGTGTGTTGTTTCGTGCAACGCGGTGCTGCCGCGGTTCCGGGGTTTCGCGCTCACCGAGGAG
 AACGCGGCGGCGGTGGCGGGGATCTGTACCGGCTCGACGGGTTGCCGCTGCCGATCGAATT
 GGCGGCGGCCCGGTTGCGGGCGATGTGCCCCAACAGATCCTGGGGCG**CCT**GACCGACCGCT

Previous known sequence →

TCACCCTGCTGACCCGCGGCAACCAGGGGTGCGCCGACGCGGCAGCAGACCCTGCGGTTGTGT
 ATCGACTGGAGCTTCGAGTTGTGCACCGCCGGTGAGCAACTGGTGTGGGGCGGGTGGCGGT
 CTTTCGCGGGGTGCTTCGAACTCGATGCCGCGGAGCAGGTGTGTGGCGAGGGCCTGGCCTCGG
 GCGAGTTATTGGACACGCTGACCTCCCTGGTGGAGAAGTCGATCCTGATCCGGGAGGAATCC
 GGGTCGGTGGTGTCTTTCCGGATGCTCGAGACTCTCCGTGAGTACGGCTACGAGAAGCTCGA
 GCAGTCCGGCGAGGCATTGGATCTGCGTCGCCGGCACCAGGAAATTGGTACGAGGCGTTGGCGC
 TGGATGCGGAAGCCGAGTGGATCAGCGCGGCCAACTCGACTGGATCACCCGGCTGAAGCGG
 GAACAACCGAATCTGCGGGAGGCCCTCGAATTCGGCGTCGACGACGATCCCGTCGCCGTCT
 GCGCACCGCCGCGCACTGTTCTGTTCTGGGGCTCTCAGGGCCTCTACAACGAGGGGCGGC
 GCTGGCTCGGCCAGCTGCTCGCCCGCAGAGCGGCCACCGACGGTTCGAGTGGGTCAAGGCC
 CTCGAACGCGCCGGCATGATGGCCAATGTGCAGGGTGTGACTGCCGGAGCCGCACTCGT
 GGCGGAGGGGCGAGCGCTCACTGCCACACGAGTGACCCATGATGCGGGCTCTCGTTGCAT
 ACGGCGATGGCATGCTTGCCCTCTACAGCGGTGATCTGGCGCGTGCCTTTCGGACCTCGAA
 ACCGCTCTGACGGAGTTCACCGCGCGCGGTGACCGAACGCTCGAAGTAGCCGCACTGTACCC
 GTTGGGGTTGGCGTACGGACTGCGCGGCTCGACGGACCGGTCGATCGAACGTCTCGAGCGCG
 TTCTCGCGATCACGGAGCAGCACGGCGAGAAAATGTATCGGTGCGCACTCGTTGTGGGCTCTG

GGTATCGCCCTGTGGCGGCACGGGGACGGCGATCGCGCGGTCCGCGTGCTCGAGCAGTCGCT
GGAGGTGACCCGGCAAGTGCACGGCCACGTGTGCGCCGCTCCTGTCTCGAGGCACTGGCCT
→ *orfA1* start
GGATAGCCTGCGA**ATG**CGTGACGAACCGAGGGCTGCGGTTCTGTTGGGAGCCGCAGAAGAGT
TGGCGCGATCAGTGGGCAGTGCCGTGG**TGA**TCTACTCCGATCTTCTTGTCTACCATCAGGAA
orfA2 stop
TGCGAACAGAAGTCTCGACGGGAACTCGGGGACAAAGGATTTCGCGGGCGCCTACCGCAAGGG
TCAGGGACTCGGTTTCGACGCGGCCATCGCCTATGCCCTCCGCGAGCAACCGCCGAGCACCT
CCGGACCCACCGCCGGTGGGTTCGACGCGACTGACCAAGCGGGAACGCCAAGTCGCCGGCCTC
ATCGCCGAAGGTCTACCAACCAGGCCATCGCCGACCGCCTGGTGATCTCTCCACGGACCGC
GCAAGGGCACGTGGAGCACATCCTGGCCAAGCTGGGTTTCACGTCCCGGGCGCAGGTTCGCGG
CCTGGGTTCGTGAGCGGACCGACGACT**TGA**ATGGAACACCTCCGCTCGCGTTGAACGCGGCAG
orfA1 stop
TCGGTGACGACCGCGACCGCGGGTTCGGTCCCTGGAATCGCGACGTAAACGGTTCTCCCCGAA
CATATGTGGCCTTTCGTTTCGCGTTGCTGCGCGCCCGCCATTTCCCGTCGTGGGACCGAATC
GCCCCGCACGCACCGGCCCGCGAAATCTGCTCCCTC**TTGACAG**CGGGCGGTGGTGCTCG**TA**
-35
ACGTCCGTGGAGTTCCAAATAATGATGTCAGTTCAGCATAGT**GAACGG**AGCTTGTG**ATGGG**
-10 *orfB* start →
G . . .

Fig.20. Nucleotide sequence upstream of *orfB* showing *orfA1* and *orfA2*. The start and stop codons are indicated by bold type. - 35 and - 10 hexamers are indicated by bold type and underling; Shine-Dalgarno sequences are underlined.

3.5.2. Construction of deletion mutant strain for *orfA2*

An unmarked deletion mutant strain for *orfA2* was constructed using the mobilisable plasmid pK18*mobsacB* (see 3.2.8.). The *orfA2* was deleted from nucleotides 1071 to 2253 as follows: two 1 kb-DNA fragments flanking region to be deleted, were amplified using two pairs of primers KO-*orfA2*-for, ClaI1-*orfA2* and ClaI2-*orfA2*, KO-*orfA2*-rev (Table 4, number 30-33). The two PCR products were digested with *ClaI* and ligated creating a 2.1 kb-ligated fragment. The fragment was inserted into *SmaI* site of pK18*mobsacB*. The resulting plasmid pNGA37 was transformed into *E. coli* S17.1 and subsequently transferred to the wild type strain *R. opacus* HL PM-1 by conjugation as described in section 3.2.8 (Fig.21A). Genotypes

of the mutant strains were analysed by Southern hybridisation of a 456 bp fragment of *orfA2* (see 3.5.1 for *orfA2* probe) against total DNA of the mutant strains digested with *EcoRI* (Fig.21B). Southern blot analysis of the wild-type strain HL PM-1 showed a hybridisation signal of 4230 bp (lane 6). As expected, the mutant strains had one hybridisation signal at 3048 bp (lane 1, 2, 4, 5). This result coincides with the sequence organisation of the wild-type strain and the mutant strain (Fig.21A). It shows that the mutant strains contained the deleted *orfA2*.

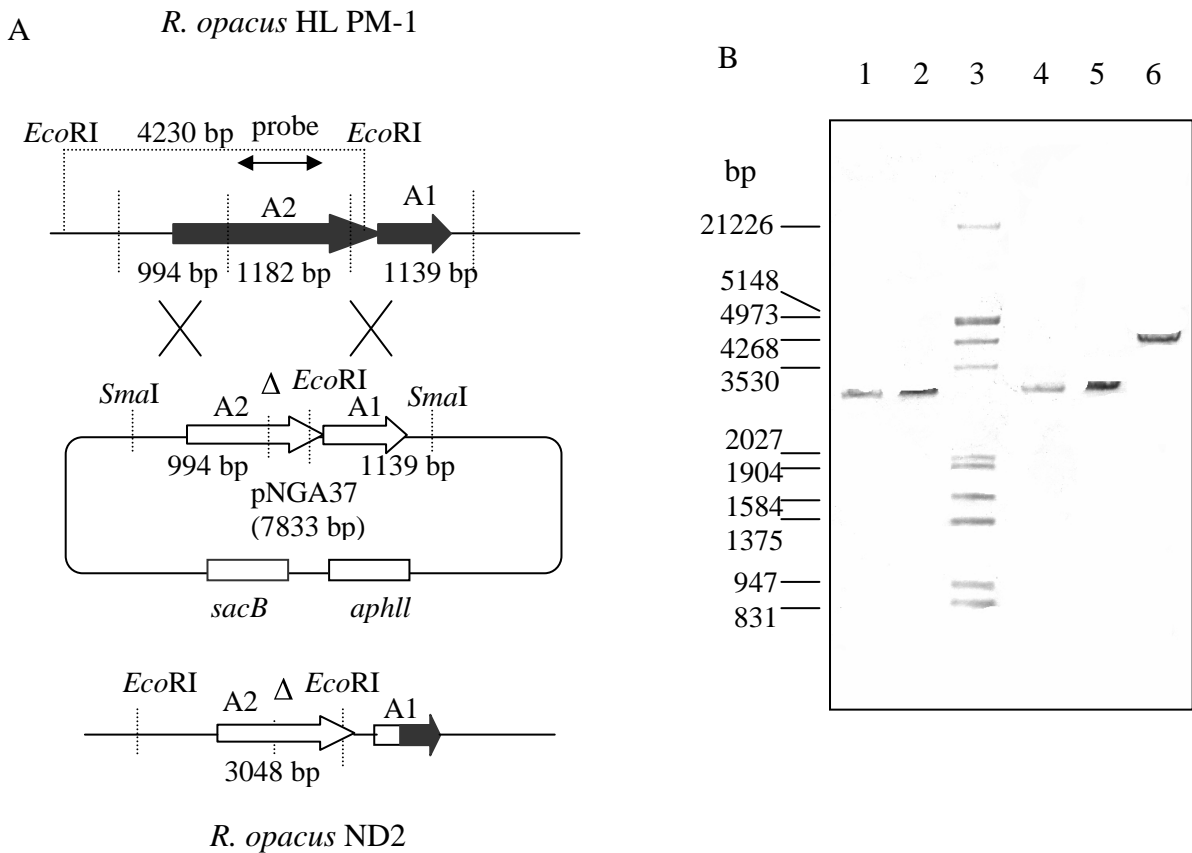

Fig.21. A. Schematic overview of the molecular organisation of the region encoding *orfA2* in wild-type *R. opacus* HL PM-1 and in deletion mutant strain *R. opacus* ND2. B. Southern analysis of chromosomal DNA from *R. opacus* digested with *EcoRI*. 1, 2, 4, 5. DNA from mutant strains with double-cross over; 3. λ -DNA digested with *EcoRI* and *HindIII* marker; 6. DNA from wild-type strain. Total DNA was isolated and digested with *EcoRI*. The digested DNA was separated on a 0.8 % (w/v) agarose gel and then transferred to a nylon membrane. The membrane was hybridised with the 5' end of the known sequence of *orfA2* and detected following the instructions of Roche.

3.5.3. Characterisation of deletion mutant *R. opacus* ND2

3.5.3.1. HTI or HTII activity of *R. opacus* ND2

HTII and HTI were shown to be involved in the initial steps of TNP metabolism (Heiss et al., 2002) and their corresponding genes *npdI* and *npdC* are located immediately downstream of the putative promoters (see 3.1). Therefore, any regulation controlling the expression of *npd* genes from the two promoters would directly affect the activities of HTII and HTI. Further, because *orfA2* and *orfA1* may encode for transcriptional regulators of a two component regulator system, hence inactivation of *orfA2* or *orfA1* may result in a change of HTI or HTII activity. To test the effect of the *orfA2* deletion on HTII and HTI activities, enzyme assays of HTI (NpdC) or HTII (NpdI) were performed with cell extracts of wild-type *R. opacus* HL PM-1 and the mutant *R. opacus* ND2 (Table 8).

Table 8. Specific activity of HTII or HTI in *R. opacus* HL PM-1 or *R. opacus* ND2

Bacterium	Specific activity (mU/mg cell extract)	
	TNP	H-TNP
<i>R. opacus</i> HL PM-1 Not induced	11 ± 2	0.7 ± 0.5
<i>R. opacus</i> HL PM-1 Induced with 0.5 mM DNP	334 ± 20	38 ± 3
<i>R. opacus</i> ND2 Not induced	12 ± 2	0.6 ± 0.5
<i>R. opacus</i> ND2 Induced with 0.5 mM DNP	324 ± 22	43 ± 4

The values are the means of two independent experiments, each done in triplet.

DNP-induced cell extracts of the wild-type strain HL PM-1 possessed 334 mU/mg protein for HTII activities or 38 mU/mg protein for HTI activities. Similar activities for HTII or HTI were observed with induced cell extracts of the mutant ND2, 324 or 43 mU/mg protein respectively. In addition, non-induced cell extracts of the mutant strain possessed equal activities for HTII or HTI (12 or 0.6 mU/mg protein) compared to those of the wild-type (11 or 0.7 mU/mg protein). Hence, there were no changes in HTII or HTI activities between the

wild-type HL PM-1 and the mutant ND2. In other words, non-functional *orfA2* did not alter the expression of *npdC* or *npdI* from the putative promoters in IGRI' or IGRIV'.

3.5.3.2. Conversion of TNP by resting cells of *R. opacus* ND2

To confirm that deleting *orfA2* did not affect expression of *npdI* or *npdC* as well as other genes of TNP metabolism, resting cells of the mutant strain *R. opacus* ND2 were performed with TNP as the substrate (Fig.22).

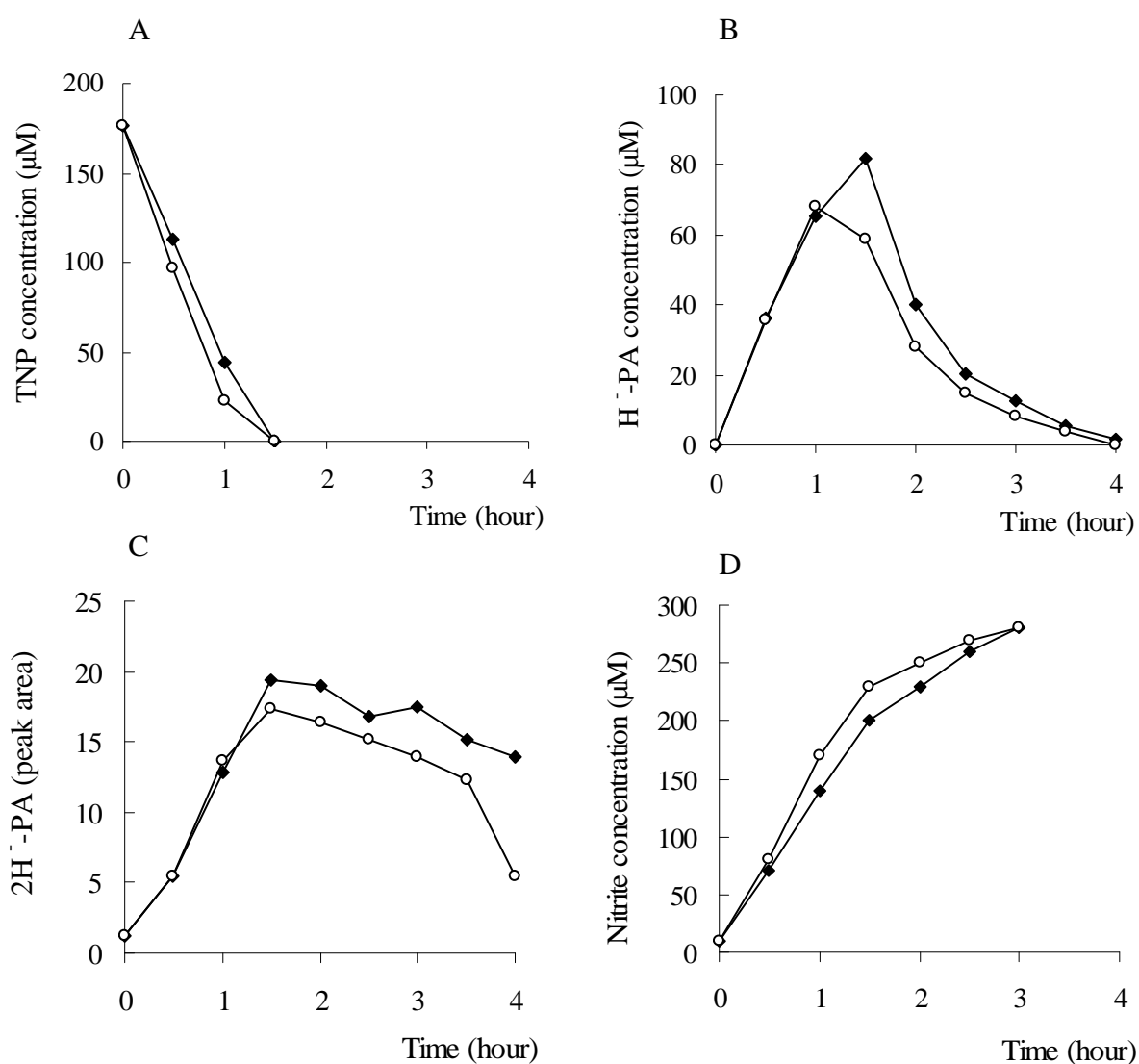

Fig.22. Conversion of TNP by resting cells of *R. opacus* HL PM-1 (◆) or *R. opacus* ND2 (○). A. Reduction of TNP concentration; B. Formation of H⁻-TNP. C. Formation of 2H⁻-TNP. D. Release of NO₂⁻ from TNP. The cultures were induced with 0.5 mM DNP for 2 h and then harvested. The cells were resuspended in KH₂PO₄/K₂HPO₄ buffer (50 mM, pH 7.5) supplemented with TNP. The OD_{600nm} of the cell suspensions was 0.9. The samples were collected at relevant time intervals and analysed by

HPLC as described in Materials and Methods. The values are the average values of two independent experiments.

TNP was converted to H-TNP almost at the same rate by resting cells of the wild-type HL PM-1 and the mutant ND2 (Fig.22A and 22B). Subsequently, H-TNP was converted to 2H-TNP by both strains almost equally (Fig.22B and 22C). In addition, NO_2^- was released during TNP transformation in both strains at similar concentrations (Fig.22D). In conclusion, there was no difference between the wild-type HL PM-1 and the mutant strain ND2 in TNP transformation. Hence, deleting *orfA2* did not change the expression of the *npd* genes from IGRI and IGRIV promoters.

3.5.4. Expression of *orfA1* in *E. coli*

To confirm that *orfA1* codes for a protein and to study the function of the encoded protein, *orfA1* was expressed in *E. coli* and the expressed protein was purified. *orfA1* was amplified using OrfA1-for and OrfA1-rev primers (Table 4, number 25, 26) and inserted into *NdeI* and *BamHI* sites of pAC28 with 6 histidines fused at the N-terminus of the corresponding protein resulting in pNGA38 (Fig.23A). SDS-PAGE analysis of the product of *orfA1* showed a single polypeptide band at about 18 kDa (Fig.23B), coinciding with the size of the translated DNA sequence of *orfA1*, 16004,1 Da. The protein was purified using Ni-NTA affinity chromatography.

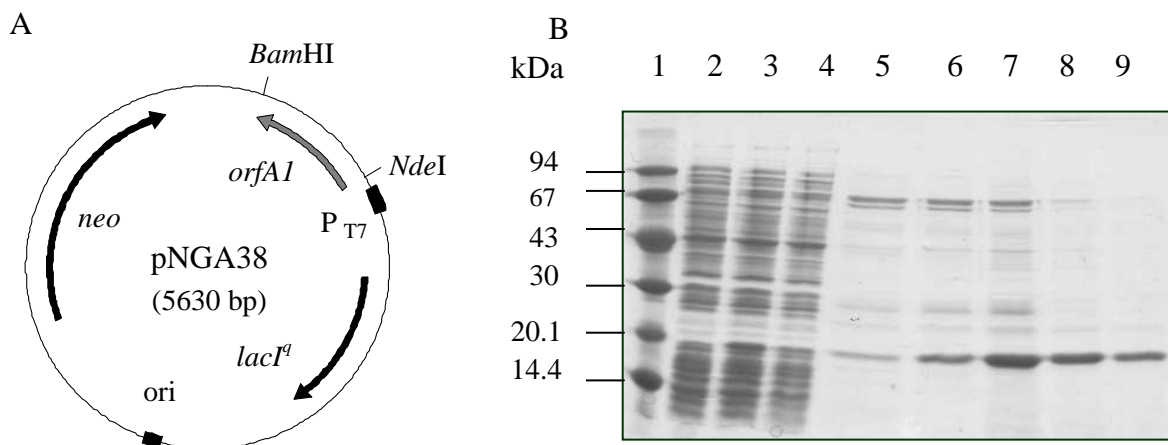

Fig.23. A. Plasmid pNGA38 contains *orfA1*. *lacI^q*: *lac* repressor; *neo*: kanamycin resistant gene; P_{T7} : T7 promoter. B. SDS-PAGE showing the purification of the product of *orfA1* with Ni-NTA affinity chromatography. 1. Low molecular weight standard; 2. Crude extract *E. coli* BL21 (DE3)(pAC28); 3. Crude extract *E. coli* BL21 (DE3)(pNGA38); 4. Fraction obtained after loading through the column; 5.

Washing fraction; 6-9. Elution fractions. The protein was purified according to the instructions of the supplier. Each purification fraction was separated on a 12 % (w/v) polyacrylamde gel.

3.5.5. Construction of mutant minus *orfA1*

Under the conditions tested, the non-functional *orfA2* mutant did not affect the expression of *npd* genes from the two promoters (see 3.5.3). To identify the function of *orfA1*, the complete *orfA1* was deleted *in vivo* using the same method used for constructing the other deletion mutants (see 3.2.8 and 3.5.2). 1 kb-flanking sequences of *orfA1* were ligated and the ligated DNA fragment was cloned into *Sma*I sites of pK18*mobsacB* resulting pNGA29. Further experiments were performed as described in section 3.2.8. Total DNA of the mutants was analysed by PCR and Southern hybridisation. Colony PCR with OrfA1 probe-for and OrfA1 probe-rev primers (Table 4, number 38, 39) on Suc^r/Kan^s colonies resulted in two different types of PCR products: one with a size of 904 bp (Fig.24A, lane 3-4) and the other with a size of the wild type 1473 bp (lane 2 or 6). The 1474 bp PCR fragment containing *orfA1* was used as the probe to hybridise with total DNA of *R. opacus* strains digested with *Eco*RI and *Bam*HI (Fig.24B). As expected, two hybridisation signals were observed in the wild-type strain: one at 2626 bp, the other was about 1450 bp (lane 2). The mutant strain showed a signal at 1450 bp and one at about 2080 bp (lane 3), confirming the absence of *orfA1*.

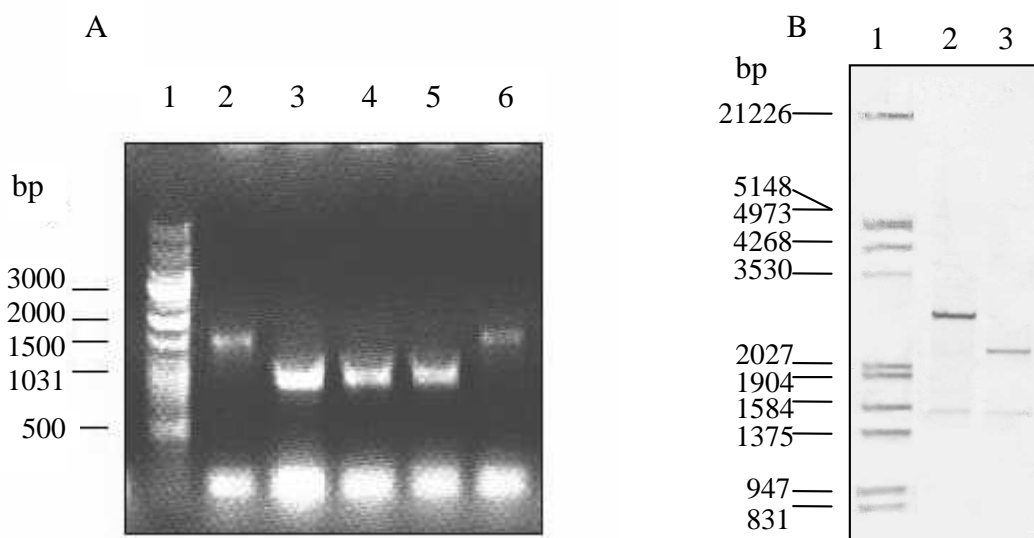

Fig.24. A. PCR of Suc^r/Kan^s colonies to screen for double-cross over mutants. 1. GeneRuler™ DNA Ladder; 2; 6. Mutant with single-cross over; 3-5. Mutant with double-cross over. B. Southern analysis of *R. opacus* chromosomal DNA digested with *Eco*RI and *Bam*HI. 1. λ-DNA digested with *Eco*RI and *Hind*III marker; 2. Wild-type strain; 3. Mutant strain with double-cross over. Total DNA of *R. opacus*

strains were isolated and digested with *EcoRI* and *BamHI*. The digested DNA was separated and then transferred to a nylon membrane as described in section 3.5.2. The membrane was probed with 1474 bp DNA fragment containing *orfA1* and detected following the instructions of Roche.

3.5.6. Characterisation of mutant *R. opacus* ND3

3.5.6.1. HTI or HTII activities in *R. opacus* ND3

As explained in section 3.5.3.1, any transcriptional regulators controlling the expression of the *npd* genes from the two promoters would directly be demonstrated by changes in HTI and HTII activities. To investigate that inactivating *orfA1* has any effect on the expression of the *npd* genes or not, HTII and HTI activities from cell extract of the wild-type strain *R. opacus* HL PM-1 were compared to those of the mutant *R. opacus* ND3 (Table 9). DNP-induced cell extracts of the wild-type exhibited approximately 303 mU/mg for HTII activities or 70 mU/mg for HTI activities. The same activities were observed with the induced cell extracts of the mutant, 334 mU/mg for HTII or 60 mU/mg for HTI. Non-induced samples of both strains also showed comparable activities for HTII and HTI. Hence, deleting *orfA1* did not affect the expression of either *npdC* or *npdI*.

Table 9. Specific activities of HTI or HTII in *R. opacus* HL PM-1 compared to *R. opacus* ND3

Bacterium	Specific activity (mU/mg cell extract)	
	TNP	H-TNP
<i>R. opacus</i> HL PM-1 Not induced	18 ± 2	05. ± 0.5
<i>R. opacus</i> HL PM-1 Induced with 0.5 mM DNP	303 ± 16	70 ± 2
<i>R. opacus</i> ND3 Not induced	17 ± 1	1.2 ± 0.5
<i>R. opacus</i> ND3 Induced with 0.5 mM DNP	334 ± 1	60 ± 1

The values are the means of two independent experiments, each was done in triplet.

3.5.6.2. Conversion of TNP by resting cells of *R. opacus* ND3

To confirm that the non-functional *orfA1* mutant did not exhibit any change in expression of *npdC* or *npdI*, resting cells experiments of the mutant ND3 were performed with TNP as the substrate and compared with the wild-type strain. The metabolites were analysed by HPLC and this showed that TNP was converted with a slightly decreased rate by the mutant cells (Fig.25A). H-TNP was formed and converted faster by the wild-type cells compared to the mutant cells (Fig.25B). However, this difference between the wild-type HL PM-1 and the mutant ND3 was not significant and did not coincide with the activities measured for HTII and HTI (see 3.5.6.1). Additionally, nitrite eliminating activities in the cell extracts of the two strains were also comparable between HL PM-1 (16 mU/mg) and the mutant ND3 (13 mU/mg). Hence, under the investigated conditions, inactivating *orfA1* did not show any significant change in expression of the TNP metabolic genes from IGRI and IGRIV promoters.

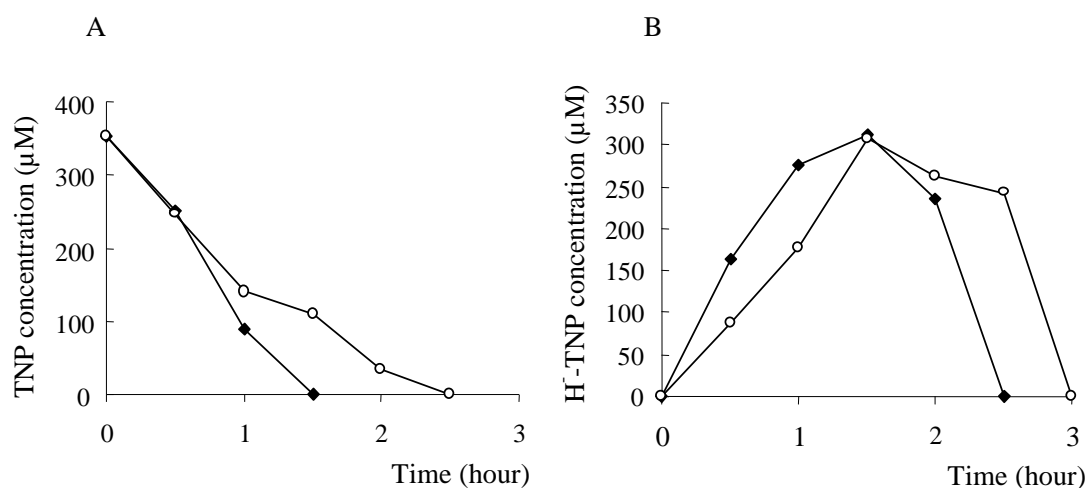

Fig.25. Conversion of TNP by resting cells of *R. opacus* HL PM- 1 (◆) and *R. opacus* ND3 (○). A. Decrease in TNP concentration; B. Formation of H-TNP. The resting cells were prepared as described in section 3.2.9.2. The samples were collected at relevant time intervals and analysed by HPLC as described in Materials and Methods. The values are the average values of two independent experiments.

Since strain HL PM-1 utilises TNP as sole carbon and nitrogen source (Rieger et al., 1999), a change on growth with TNP as nitrogen or carbon source may be expected for the mutant of *orfA1* or *orfA2*. Hence, the mutant strains ND3 and ND2 were cultured on minimal medium supplemented with TNP as a nitrogen or carbon source. The growth rates of both mutant

strains with TNP as a nitrogen source were similar with that of the wild-type HL PM-1 (data not shown). For an unknown reason the strain HL PM-1 and the mutants did not grow on TNP as a carbon source. Therefore, comparing the growth rate of HL PM-1 and the two mutant strains was not possible. These results, together with the previous study on the non-functional *orfA2* suggest that *orfA1* and *orfA2* may not play a role in regulation of TNP utilisation as nitrogen source. Alternatively, they may still function normally due to the presence of another copy in the mutants.

3.6. Localisation of the *npd* genes

3.6.1. Localisation of the *npd* genes in *R. opacus* HL PM-1

Linear and circular plasmid DNA molecules have been detected in many strains of *Rhodococcus* species (Prescott, 1991; Dabrock et al., 1992; Kalkus et al., 1993; Masai et al., 1997). *Rhodococcus* sp. strain CB 24-1 was shown to contain a plasmid and its *npdG*, *npdR*, *npdH*, and *npdI* genes have two copies, one is localised on the chromosomal DNA and the other is localised on the plasmid (S. Weishaupt, N.Trachtmann, G. Heiss unpublished data). As shown in section 3.5, inactivation of *orfA2* or *orfA1* in the chromosomal DNA of *R. opacus* HL PM-1 did not show any effect on expression of the *npd* genes from the two promoters. Hence, it is not surprising if *orfA1* and *orfA2* are present in more than one copy in the strain. This is possible, even though a complete inactivation of NpdR activity in the deletion mutant *R. opacus* ND1 suggests that *npdR* may be present in *R. opacus* HL PM-1 as a single copy (see 3.2.9). To clarify this, total DNA of *R. opacus* HL PM-1 was analysed by PFGE to search for the presence of endogenous plasmids. The PFGE showed that strain HL PM-1 contained two plasmids (Fig.26). The resolved DNA was then hybridised with Dig-labeled probes (Table 10).

Table 10. Dig-labeled probes used for hybridisation with total DNA of *R. opacus* HL PM-1 resolved by PFGE.

Probe	Primer to amplified the DNA	Length of the probe
<i>orfA1</i>	OrfA1-for and OrfA1-rev (Table 4, number 25, 26)	450 bp (complete sequence)
Part of <i>orfA2</i>	OrfA2probe-for and OrfA2probe-rev (Table 4, number 28, 29)	456 bp (nucleotide 33-488)*
Part of <i>npdC</i>	npdC probe-for and npdC probe -rev (Table 4, number 34, 35)	517 bp (nucleotide 3126-3643)*
<i>npdI</i>	DH2 Nde-for and DH2 Bam-rev (Table 4, number 36, 37)	1047 bp (complete sequence)
<i>npdR</i>	Val-npdR-for and Bam-npdR-rev (Table 4, number 1, 2)	756 bp (complete sequence)

* Position from the known sequence of *npd* gene cluster (Accession number AF323606).

The hybridisation analyses demonstrated that *npdC* (Fig.26A), *npdI* (Fig.26B), *npdR* (Fig.26C) *orfA1* (Fig.26D) and *orfA2* (Fig.26E) hybridised to the chromosomal DNA of strain HL PM-1 but did not hybridise to the chromosomal DNA of strain SQ1 (negative control, unable to grow on DNP or TNP). Previously, Southern hybridisation of digested total DNA from the strain with labeled *npdR* (Fig.12B), *orfA1* (Fig.21B), or *orfA2* (Fig.24B) as probe showed that those genes exist as a single copy on the chromosomal DNA. Therefore, deleting *orfA1* or *orfA2* did not have effect on expression of the *npd* genes from IGRI and IGRIV promoters or on the growth with TNP as nitrogen source due to the fact that *orfA1* and *orfA2* may be not involved in utilisation of TNP as nitrogen source.

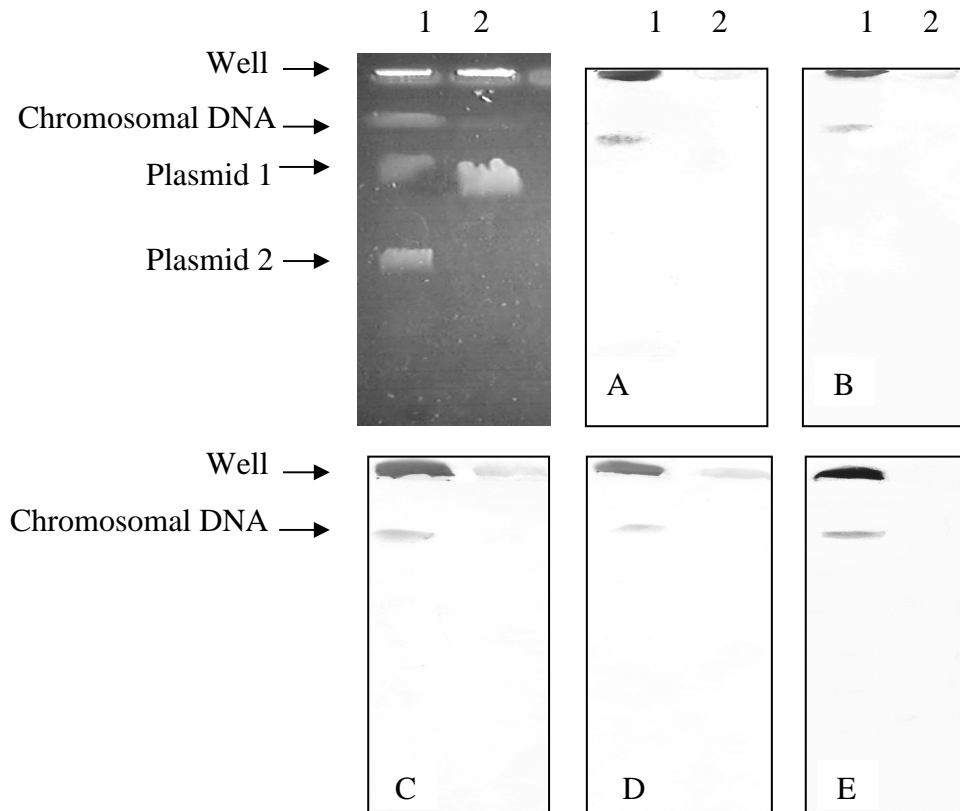

Fig.26. Southern analysis of total DNA from *R. opacus* HL PM-1 resolved by PFGE with *npdC* probe (A), *npdI* probe (B), *npdR* probe (C), *orfA1* probe (D), and *orfA2* probe (E). 1. Total DNA of *R. opacus* HL PM-1. 2. Total DNA of *R. opacus* SQ1 (negative control, the strain does not grow on DNP or TNP). After PFGE the DNA was transferred to a nylon membrane under alkaline conditions. The temperature for hybridisation and washing was 60 °C.

3.6.2. Localisation of the *npd* genes in *N. simplex* FJ2-1A

TNP metabolic potential was shown to be inducible in *R. opacus* HL PM-1 but constitutive in *N. simplex* FJ2-1A (see 3.4.4). Further, it was demonstrated that *npdC*, *npdF* *npdG*, *npdH* and *npdI* genes from *N. simplex* FJ2-1A have the same functions as the corresponding *npd* genes in *R. opacus* HL PM-1 (Hofmann, 2003). In order to better understand the TNP metabolism in *N. simplex* FJ2-1A and be able to compare the two strains, the location of the *npd* genes in *N. simplex* FJ2-1A was determined. PFGE of total DNA from *N. simplex* FJ2-1A revealed an endogenous plasmid corresponding to the 97 kb fragment of the DNA marker. For preparing the probes, *npdR* was amplified from the total DNA of *N. simplex* FJ2-1A using primers NdeI-*npdR*-FJ and BamHI-*npdR*-FJ (Table 4, number 40, 41), *npdC* and *npdI* were amplified from the total DNA of *R. opacus* HL PM-1 (see Table 10). Southern analyses of PFGE

against *npdR*, *npdC* or *npdI* probes showed that *npdR*, *npdC* and *npdI* genes are localised on the plasmid (Fig.27). This differs from the location of the *npd* genes in strain HL PM-1, which possesses the genes on the chromosome.

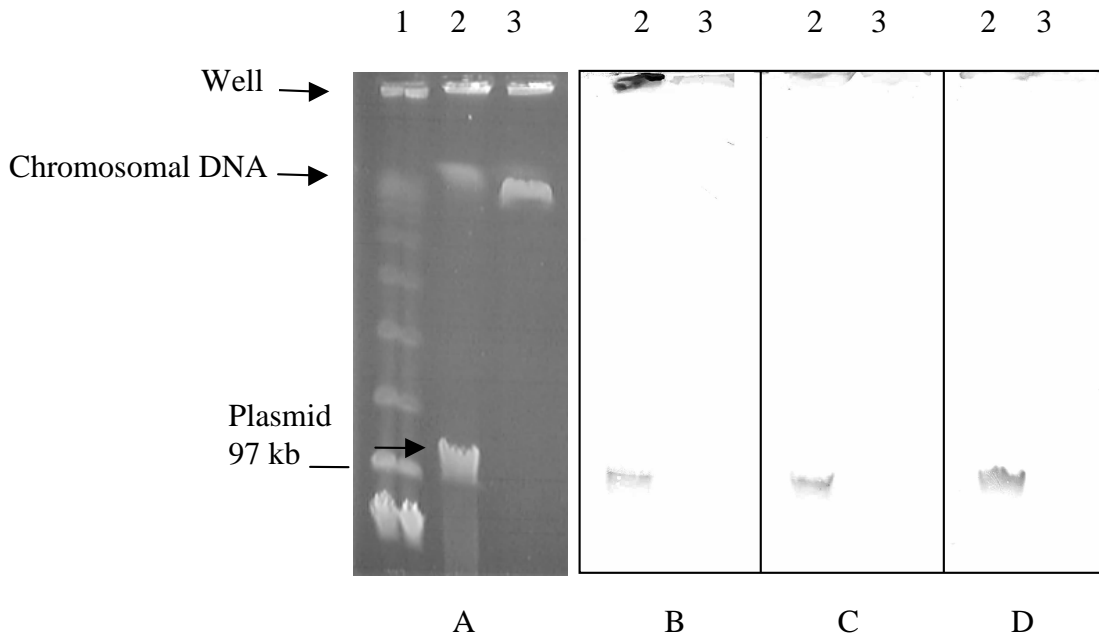

Fig.27. Southern hybridisation of *npdC* (B), *npdI* (C), *npdR* (D) probes against genomic DNA of *N. simplex* FJ2-1A. (lane 2) and *R. opacus* SQ1 (negative control, lane 3) resolved by PFGE. PFGE marker is in lane 1. The DNA was transferred to a nylon membrane and probed with Dig-labeled DNA as described in section 3.6.1.

4. Discussion

4.1. *Rhodococcus* promoters in nitroarene degradation

Two promoter regions are present in the *npd* gene cluster. One locates upstream of *orfB* and the other locates between *npdH* and *npdI*, suggesting that the *npd* gene cluster may consist of at least two operons. The putative -10 and -35 hexamers of the promoters are similar to those recognised by *E. coli* RNA polymerases containing sigma 70-like subunits. *E. coli* promoters recognised by sigma 70 have a typical -35 hexamer TTGACA, and spacers between the -10 and -35 hexamer of 16-18 nucleotides (Strohl et al., 1992). *E. coli* sigma 70-like promoters have also been found in the hydrogenase gene cluster of *R. opacus* MR11 and the nitrile-degrading operon of *Rhodococcus* sp. ACV2. Sequence alignment of these two promoters regions with the two-*npd* promoter regions revealed a high similarity in the conserved -35 and -10 hexamers of the promoters (Fig.28). It is not surprising since *E. coli* like-promoter sequences were found to be rather common in *Rhodococcus* (Grzeszik et al., 1997; Barnes et al., 1997; Bigey et al., 1999). This finding is in agreement with *E. coli* like-promoters of *Streptomyces* (Strohl et al., 1992).

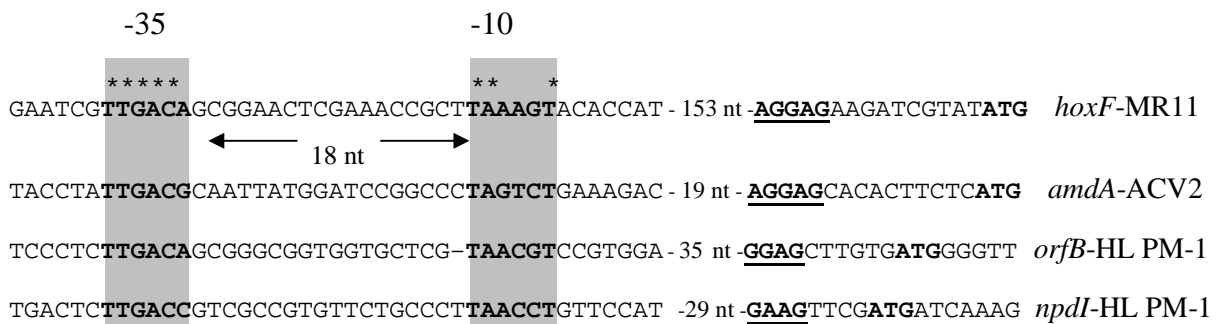

Fig.28. Sequence comparison of the promoter regions from *npd* operons showing the -35 and -10 hexamers. Top: promoter sequence of the hydrogenase gene cluster from *R. opacus* MR11 (*hoxF* gene encoding the alpha subunit of the hydrogenase, Genbank U70364). Second from top: upstream sequence of the *amdA-nthAB* genes from *Rhodococcus* sp. ACV2 (*amdA* gene encoding the amidase protein Z48769). Third from top: upstream sequence of the *orfB* gene from *R. opacus* HL PM-1. Bottom: upstream sequence of the *npdI* gene from *R. opacus* HL PM-1 (Genbank AF323606). Boxes indicate conserved -35 and -10 regions; putative Shine-Dalgarno sequences are indicated by bold type and underlining; translation start codons are indicated by bold type.

Rhodococcus promoter regions involved in nitroarene degradation have not been identified before. To date, the only known promoters involved in nitroaromatics degradation are from Gram-negative bacteria, which utilise nitroarene dioxygenases to initiate aerobic growth with nitroaromatic compounds (Parales, 2000). Among them, transcriptional start sites have been identified only for *nbz* (nitrobenzene degradation) and *ntd* (nitrotoluene degradation) operons from *Comamonas* sp. strain JS765 and *Acidovorax* sp. strain JS42 (Lessner et al., 2003), respectively. For *dnt* (dinitrotoluene degradation) operons, transcriptional start sites or promoter activities still remain to be determined in order to conclude whether the putative promoter regions contain promoters or not (Lessner et al., 2003). In this study, we show that the two identified promoter regions of *npd* genes indeed contain promoters, since the expression of the reporter gene (*xylE*) increases 50-70-fold under the control of the two promoter regions (Fig.4). Unfortunately, the primer extensions to determine the transcriptional start sites of the two transcripts, did not give clean single signals.

4.2. IclR-type and LysR-type repressors in nitroarene degradation

Database comparisons with the sequence of NpdR showed 40 to 42 % sequence similarities to transcriptional regulators of the IclR family in *Bacillus halodurans*, *Salmonella enterica*, *Yersinia pestis* and *E. coli*. (expect values: $2e^{-11}$ to $1e^{-0.9}$). Sequence similarities of 40 to 42 % to KdgR (LacI family) transcription regulators of *S. enterica*, *Pectobacterium carotovorum* and *E. coli* were also identified (expect values: $9e^{-10}$ to $6e^{-10}$). An IclR helix-turn-helix (HTH) motif was detected at the N-terminal end of NpdR as well as in IclR from *E. coli* (Sunnarborg et al., 1990), PcaR and CatR from *R. opacus* (Eulberg et al., 1998) and PcaU and PcbR from *Acinetobacter* (Gerischer et al., 1998). The HTH motif was identified at amino acid positions 21 to 42 of NpdR with 90 % probability (Dodd et al., 1990, Network. Protein Sequence Analysis). The helix-turn-helix motif has been found in a variety of prokaryotic and eukaryotic DNA-binding proteins and has been shown, in some cases, to constitute an essential part of the DNA-binding domain (Sauer et al., 1982; Yudkin, 1988). The location of this sequence very near the amino terminus of NpdR is reminiscent of most of these DNA-binding proteins.

In this work, *in vivo* inactivation of *npdR* showed that NpdR is a repressor, which represses expression of the TNP metabolic genes. A weak promoter activity was seen for the region upstream of *npdR* (Fig.14), suggesting the presence of a weak promoter for *npdR* itself. It is

rather common in bacteria that regulatory proteins are expressed at a low level from their own promoters and their expression is autoregulated (Gui et al., 1996a). However, in this case, if there is any regulation controlling NpdR expression, it is probably not autoregulation, since NpdR did not bind to its own upstream sequence (see 3.2.3). Regulation of the expression of a regulator by another regulator has been reported for FadR; it activates expression of the IclR repressor (Gui et al., 1996b). A similar situation may be speculated for NpdR. On the other hand, DNP did not affect *xylE* expression from this putative promoter, suggesting that this weak promoter may work constitutively. The promoters for weakly expressed constitutive genes have also been reported for *lacI* (lactose repressor gene) and for *bphS* (regulator of two-component regulatory system for biphenyl degradation in *Rhodococcus* sp. RHA1) (Calos, 1978; Takeda et al., 2004). However, the presence of a promoter upstream from *npdR* still needs to be confirmed by determining the start site of transcription. Further, questions remain, such as: Is there any regulator controlling the expression of NpdR or not? If yes, then the mechanism remains to be addressed.

IclR-type regulators have been described mostly for *E. coli* (Sunnarborg et al., 1990; Gui et al., 1996a, 1996b; Shin et al., 1997) and *Salmonella typhimurium* (Galini er et al., 1990, 1991; Negre et al., 1991), in which case the IclR regulator is a repressor of the glyoxylate bypass operon during growth on acetate or fatty acids. Hence, it is not unexpected that NpdR was found to be a repressor. Members of the PobR subfamily of the IclR family of regulators (PcaU, PobR, CatR, and PcaR) are involved in the regulation of protocatechuate or catechol degradation in *Acinetobacter*, *Rhodococcus* and *Pseudomonas* (Gerischer et al., 1998; Eulberg et al., 1998; Gou et al., 1999).

IclR-type regulators involved in regulation of nitroarene degradation have not been described yet. In all nitroarene catabolic gene clusters analysed thus far, the respective genes are mainly under the control of LysR-type regulators: the putative regulator DntR of 2,4-dinitrotoluene degradation (Parales, 2000); PnbR, the putative regulator of the *pnb* genes encoding for 4-nitrobenzoate catabolism (Hughes et al., 2001); NbzR and NtdR, transcriptional activators for the *nbz* (nitrobenzene degradation) and *ntd* (nitrotoluene degradation) genes (Lessner et al., 2003); the two activators PnpR and PnpS of *p*-nitrophenol degradation (Zylstra et al., 2000). It seems likely that LysR-type proteins will appear more predominantly in future studies of the regulation of nitroaromatic catabolism. However, it is not surprising that NpdR belongs to a different type of regulator, since the mentioned nitroarene compounds are degraded by an

oxidative attack mechanism in contrast to the reduction mechanism of TNP and DNP. Thus, the difference in the degradation mechanism may require different regulation.

4.3. Binding of IclR-type repressors to DNA-binding regions

Gel retardation assays with purified His-tag fusion NpdR demonstrated that NpdR-His formed two complexes, C1 and C2 with both IGRI' and IGRIV' in the absence of inducer (Fig.8). This suggests that NpdR might be a homodimeric protein that binds to two sites on the IGRs. When NpdR binds to the two sites in the IGRs, C1 is detected. At lower NpdR concentrations, the two binding sites may not be saturated, hence forming a second complex C2. The formation of C2 in the presence of a decreasing protein concentration suggests a lack of coordinate binding of NpdR to the two DNA-binding sites (NpdR molecules bind to the sites independently). Adding DNP to the GMSA reaction mixtures causes decrease in the DNA-binding affinity of NpdR, formation of C1 or even C2 was prevented and free DNA was visible (Fig.11).

Two direct repeat regions (DR) with very high sequence similarity to each other, were found immediately downstream of the two promoter regions of the *npd* gene cluster (Fig.3). Gel retardation assays with the DR of IGRI' (see 3.2.7), confirmed that it is the binding site for NpdR. Because the sequence of the DR in IGRI' is 82 % identical to that of the DR in IGRIV' (Fig.3), it is presumed that the DR of IGRIV' is also the binding site for NpdR. This is logical, since NpdI and NpdG are required for the first hydrogenation reaction, NpdC and NpdG are required for the second hydrogenation reaction (see Fig.1 and 2). Hence, the two operons need to be co-ordinately regulated. These findings strengthen the above hypothesis.

A similar result has been reported for PcaR, an activator for protocatechuate degradation in *P. putida* (Gou et al., 1999). Two imperfect direct repeat sequences overlapping the -35 and -10 region of the *pcaI*, *J* promoter (*pca* gene encodes for enzymes of protocatechuate utilisation) are found. PcaR interacts with one of the direct repeat resulting in one PcaR-DNA complex. As PcaR binds to the two direct repeats, a bigger complex is formed. Several DNA-protein complexes have been also found as PcaU (activator of genes for protocatechuate utilisation in *Acinetobacter*) binds to a DNA sequence directly downstream from *pcaU* (Gerischer et al., 1998). Hence, the way NpdR binds to the DNA does not seem to be a rare phenomenon in IclR-type regulators. However, in order to clarify the binding mechanism of NpdR to DNA, DNase I-footprinting still needs to be performed.

Sequences of both direct repeats (from IGRI' and IGRIV') are rather different from those of potential binding sites for the PnpR and PnpS regulators (only 35-47 % identity) (Fig.29). PnpR and PnpS are the only known regulators of nitrophenols degradation so far, which positively regulate the *p*-nitrophenol degradation operon in *Pseudomonas* sp ENV2030 (Zylstra et al., 2000). Further, they are also different from the consensus sequence that are governed by PobR and PcaR (35 % identity) (Fig.29). PobR and PcaR are transcriptional activators, controlling expression of the genes for protocatechuate utilisation in *Acinetobacter calcoaceticus* and *P. putida*, respectively (Gerischer et al., 1998). It is no wonder why the sequence identities are low, since NpdR, PnpR and PnpS, PcaU and PobR are completely different kinds of regulators. NpdR is a repressor belonging to the IclR regulator family. PnpR and PnpS are LysR-type activators. PcaU and PobR are also IclR-type regulators, but have been showed to be transcriptional activators.

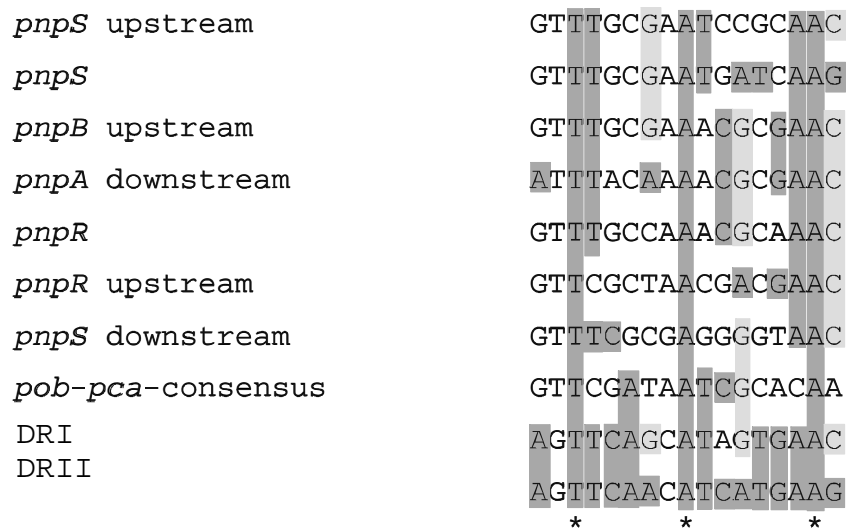

Fig.29. Alignment of direct repeat sequences in the DNA-binding regions of NpdR with potential regulatory motifs of the *pnp* operon (encodes for *p*-nitrophenol degradation in *Pseudomonas* sp. strain ENV2030) and the *pob-pca* consensus sequence (consensus sequence of the operators controlled by PobR and PcaR, activator of genes for protocatechuate utilisation in *Acinetobacter*). DRI: half of the direct repeat region of the intergenic region between *orfA-orfB*. DRII: half of the direct repeat region of the intergenic region between *npdH-npdI* (see Fig.3).

4.4. Induction of nitroaromatic compounds degradation

Here, we showed that besides DNP, TNP, 2-chloro-4,6-dinitrophenol, and 2-methyl-4,6-dinitrophenol induce expression of the *npd* genes (see 3.4) by reducing the binding affinities of NpdR to IGRI' and IGRIV' (Fig.10). Strain *R. opacus* HL PM-1 has the ability to utilise TNP and 2-chloro-4,6-dinitrophenol as sole nitrogen source (Lenke et al., 1996). Hence, it was not unexpected that NpdR responded to these analogous compounds. Strain HL PM-1 converts 2-methyl-4,6-dinitrophenol to dead-end products (Lenke et al., 1996). It is possible that NpdR binds to this compound due to its analogous structure, leading to the induction of enzymes, although the strain may not degrade it completely. 4-Nitrophenol, 2,6-dinitrophenol and TNT did not affect the binding of NpdR to either IGRI' or IGRIV'. Strain HL PM-1 did not grow on any of these compounds, a fact which may explain why these compounds did not prevent binding of NpdR (Lenke, 1990). In the case of TNT, cells induced with TNP of the strain convert TNT only to the hydride and the dihydride Meisenheimer complex of TNT, but no further transformation takes place (Vorbeck et al., 1994; Vorbeck et al., 1998). Similarity in the structures of TNP and TNT indicates that the OH⁻ group of the effector may be necessary for altering the conformation of NpdR for DNA binding, whereas the less acidic CH₃⁻ group on TNT may not have an effect.

A broad range of inducers has also been reported for NbzR in *Comamonas* sp. strain JS765 and NtdR in *Acidovorax* sp. strain JS42 (Lessner et al., 2003). NtdR is required for induction by nitrobenzene, 2-, 3-, and 4-nitrotoluene, 2,4- and 2,6-dinitrotoluene and aminodinitrotoluenes, as well as salicylate and anthranilate. The bacteria that are able to grow on nitroaromatic compounds have been isolated from sites contaminated with one or more of these compounds. Thus, due to selective pressure, bacteria appear to evolve the necessary enzymes and pathways required for degradation of these compounds. It may be an explanation for the wide effector specificity in nitroarene-degrading genes.

Up to now, the importance of systematic studies on induction and inducibility of nitroarene degrading genes has not been recognised. Often, only poor details on the inducers have been shown, for example: oxidation of *p*-nitrophenol in *Moraxella* sp. has been noted to be enhanced by pre-exposure to *p*-nitrophenol (Zylstra et al., 2000); the only inducer for *dnt* genes in *Burkholderia* sp. DNT identified so far is salicylate (Parales, 2000). There is no molecular or biochemical investigation revealing insight into the regulatory mechanisms of induction or specificity of inducers. In this work, with molecular and biochemical studies we

identified the specific inducing compounds and initiated the first studies on the regulatory mechanisms of TNP induction.

4.5. Two-component regulators in *Rhodococcus opacus* HL PM-1

Database searches for protein similarity of the protein products from *orfA1* and *orfA2* revealed that these two open reading frames might encode two components of signal transduction proteins. So far, there are not so many two-component regulatory systems that have been reported in the genus *Rhodococcus*. BpdS and BpdT potentially regulate biphenyl/polychlorobiphenyl degradation in *Rhodococcus* sp. M5 and represent the first example of a two-component system in *Rhodococcus* (Labbe' et al., 1997). Comparison of the deduced amino acid sequence encoded by *orfA2* to the sequences in the database showed 56 % sequence similarity to a serine/threonine protein kinase PknK of *Mycobacterium tuberculosis*. Normally, the main phosphorylation sites in prokaryotes are on histidine and aspartic acid residues, whereas in eukaryotes they are on serine, threonine and/or tyrosine. Interestingly, genes of this type have been detected in only few species of prokaryotes: *Streptomyces*, *Mycobacterium*, *Synechocystis* and *Myxococcus* (Ogawara et al., 1999). Hence, besides having sigma 70-like promoters, *Rhodococcus* has many features in common with *Streptomyces*.

Under the investigated conditions, the *in vivo* inactivated mutants for *orfA2* or *orfA1* did not make a difference in the expression of the *npdC* or *npdI* genes (see 3.5.3.1 and 3.5.6.1). Furthermore, resting cells of the *orfA2* or *orfA1* mutant strains exhibited no significant change in the TNP conversion rate as well as in the transformation of further intermediates in the upper pathway (see 3.5.3.2 and 3.5.6.2). Growth rates of both mutants on TNP as nitrogen source were similar to that of the wild type strain. These results suggest that *orfA1* and *orfA2* may not be involved in conversion of TNP as nitrogen source. Alternatively, there may be another copy of *orfA1* and *orfA2* genes in *R. opacus* HL PM-1.

PFGE analysis of total DNA from *R. opacus* HL PM-1 (Fig.26) demonstrates that HL PM-1 contains two endogenous plasmids, but that *orfA1* and *orfA2* were localised only on the chromosomal DNA of the strain. Furthermore, hybridisation analysis of digested DNA from HL PM-1 with an *orfA2* (Fig.21B) or *orfA1* probe (Fig.24B) showed that *orfA1* and *orfA2* are present as single copy in *R. opacus* HL PM-1. In conclusion, *orfA1* and *orfA2* do not seem to be involved in the regulation of TNP utilisation as nitrogen source.

4.6. TNP-degradation genes on plasmid DNA

Linear plasmids have been discovered in many *Rhodococcus* strains and found to encode a variety of functions such as hydrogen autotrophy in *R. opacus* (Kalkus et al., 1993), isopropyl benzene metabolism in *R. erythropolis* (Dabrock et al., 1992), biphenyl metabolism in *Rhodococcus* strain RHA1 (Masai et al., 1997), and the plant virulence/fasciation genes (*fas*) in *R. fascians* (Crespi et al., 1992). Circular plasmids are also commonly found in *Rhodococcus* species. The most well characterised plasmids are either associated with pathogenesis determinants of *R. equi* (Prescott, 1991) or involved in the degradation of chlorinated hydrocarbons in various strains (Kulakova et al., 1997).

It was shown for *R. opacus* CB24-1 that some of the TNP metabolic genes (*npdG*, *npdR*, *npdH* and *npdI*) exist as two copies in the strain (S. Weishaupt, N.Trachtmann, and G. Heiss unpublished data). One copy is localised on the chromosomal DNA and the other is localised on a plasmid. In this work, PFGE of DNA from *R. opacus* HL PM-1 also revealed the presence of two endogenous plasmids (Fig.26). However, *npdC*, *npdI*, *npdR*, *orfA1* or *orfA2* genes were shown to be localised on the chromosomal DNA of the strain only. The result is different from strain *N. simplex* FJ2-1A, where *npdC*, *npdI*, and *npdR* genes are localised on a plasmid (Fig.27).

Locations of the genes encoding degradation of nitroaromatic compounds have been investigated only recently. The *dnt* genes for 2,4-dinitrotoluene degradation are located on plasmid pJS1 (180 kb) in *Burkholderia* sp. strain DNT or on plasmid pJS311 (216 kb) in strain *B. cepacia* R34 (Parales, 2000). The genes encoding for the initial steps of *p*-nitrophenol degradation have been shown to be located on a plasmid in *Arthrobacter aureescens* TW17 (Zylstra et al., 2000). A similar finding has been reported for *P. cepacia* RKJ200, which harbours a 50 kb plasmid carrying the genes for *p*-nitrophenol degradation (Zylstra et al., 2000). Hence, it was not unexpected that the *npd* genes are located on a plasmid in *N. simplex* FJ2-1A. This finding suggests that *npd* genes may be transferred by conjugation to derivatives of the parent strain or to closely related strains and genomic rearrangement between plasmid and chromosomal DNA is also possible (Kulakov et al., 2002).

4.7. Future work

Here, we show that two sigma 70-like promoters are present in the *npd* gene cluster of *R. opacus* HL PM-1. The IclR-type repressor NpdR controls the expression of the *npd* genes by binding to specific regulatory regions within the promoter regions. NpdR has a broad effector specificity including TNP, DNP, 2-chloro-4,6-dinitrophenol, and 2-methyl-4,6-dinitrophenol. These inducers function by reducing the binding affinity of NpdR to the regulatory regions. However, the mechanism by which NpdR interacts with the DNA still needs to be elucidated. Further, questions concerning regulation of *npdR* expression still remain to be answered. Not all the genes encoding for TNP degradation are present in the known *npd* gene cluster. The gene encoding the nitrite-eliminating enzyme is still unidentified in the strain (Hofmann, 2003) hence, looking for new sequences encoding for *npd* genes may reveal the presence of other regulatory genes.

Since nitroarene compounds have been present in the environment for a relatively short time, it is likely that genes have been recruited from other pathways and these newly composed pathways are not optimised. It is probable that efficient regulatory systems have not yet evolved, especially in the more complex pathways. Moreover, another problem that may be encountered during attempts to degrade mixtures of nitroaromatic compounds is forming toxic dead-end metabolites, since most isolates are only capable of degrading a single compound. Hence, understanding the regulation of TNP degradation particularly, or nitroarenes degradation generally may help to overcome the above problems by designing a more efficient pathway. On the other hand, using genetic engineering, it is possible to combine different degradation pathways and introduce an appropriate regulatory system into a single organism to increase the substrate specificity.

5. References

1. **Barnes, M. R., W. A. Duetz, and P. A. Williams.** 1997. A 3-(3-hydroxyphenyl) propionic acid catabolic pathway in *Rhodococcus globerulus* PWD1: cloning and characterisation of the *hpp* operon. *J. Bacteriol.* **179**:6145-6153.
2. **Barton, B. M., G. P. Harding, and A. J. Zuccarelli.** 1995. A general method for detecting and sizing large plasmids. *Anal. Biochem.* **226**:235-240.
3. **Behrend, C., and K. Heesche-Wagner.** 1999. Formation of hydride-Meisenheimer complexes of picric acid (2,4,6-trinitrophenol) and 2,4-dinitrophenol during mineralisation of picric acid by *Nocardioides* sp. strain CB 22-2. *Appl. Environ. Microbiol.* **65**:1372-1377.
4. **Bigey, F., H. Chebrou, D. Fournand, and A. Arnaud.** 1999. Transcriptional analysis of nitrile-degrading operon from *Rhodococcus* sp. ACV2 and high level production of recombinant amidase with an *Escherichia coli*-T7 expression system. *J. Appl. Microbiol.* **86**:752-760.
5. **Blasco, R., and F. Castillo.** 1992. Light-dependent degradation of nitrophenols by the phototrophic bacterium *Rhodobacter capsulatus* E1F1. *Appl. Environ. Microbiol.* **58**:690-695.
6. **Blasco, R., E. Moore, V. Wray, D. Pieper, K. Timmis, and F. Castillo.** 1999. 3-Nitroadipate, a metabolic intermediate for mineralisation of 2,4-Dinitrophenol by a new strain of a *Rhodococcus* species. *J. Bacteriol.* **181**:149-152.
7. **Bradford, M. M.** 1976. A rapid and sensitive method for quantification of microgram quantities of protein, utilising the principle of protein-dye binding. *Anal. Biochem.* **72**:248-254.
8. **Calos, M. P.** 1978. DNA sequence for a low-level promoter of the *lac* repressor gene and an 'up' promoter mutation. *Nature.* **274**:762-765.

9. **Crepsi, M., E. Messens, A. B. Caplan, M. Vanmontagu, and J. Desomer.** 1992. Fasciation induction by the phytopathogen *Rhodococcus fascians* depends upon a linear plasmid encoding a cytokinin synthase gene. *EMBO Journal*. **11**: 795-804.
10. **Dabbs, E. R., and G. J. Sole.** 1988. Plasmid-borne resistance to arsenate, arsenite, cadmium, and chloramphenicol in a *Rhodococcus* species. *Molec. Gen. Genet.* **211**:148-154.
11. **Dabrock, B., J. Riedel, J. Bertram, and G. Gottschalk.** 1992. Isopropylbenzene (cumene)-a new substrate for the isolation trichloroethene-degrading bacteria. *Arch. Microbiol.* **158**: 9-13
12. **Dang, P. N., J. Altenbuchner and G. S. Heiss.** 2004. NpdR, a repressor involved in 2,4,6-trinitrophenol degradation in *Rhodococcus opacus* HL PM-1. *J. Bacteriol.* **186**: 98-103.
13. **Dodd, I. B., and J. B. Egan.** 1990. Improved detection of helix-turn-helix DNA-binding motifs in protein sequences. *Nucl. Acids Res.* **18**:5019-5026.
14. **Dorn, E., M. Hellwig, W. Reineke and H.-J. Knackmuss.** 1974. Isolation and characterisation of a 3-chlorobenzoate-degrading *Pseudomonas*. *Arch. Microbiol.* **99**:61-70.
15. **Dower, W. J., J. F. Miller, and C. W. Ragsdale.** 1988. High efficiency transformation of *E. coli* by high voltage electroporation. *Nucleic Acids Res.* **16**: 6127-6145.
16. **Ebert, S., P.-G. Rieger, and H.-J. Knackmuss.** 1999. Function of coenzyme F₄₂₀ in aerobic catabolism of 2,4,6-trinitrophenol and 2,4-dinitrophenol by *Nocardioides simplex* FJ2-1A. *J. Bacteriol.* **181**:2669-2674.

17. **Ebert, S., P. Fischer, and H.-J. Knackmuss.** 2001a. Converging catabolism of 2,4,6-trinitrophenol (picric acid) and 2,4-dinitrophenol by *Nocardioides simplex* FJ2-1A. *Biodegradation*. **12**:367-376.
18. **Ebert, S.** 2001b. Enzyme, Gene und Mechanismen des oberen Abbauweges von Pikrinsäure und 2,4-dinitrophenol durch *Nocardioides simplex* FJ2-1A. Ph.D. thesis. University of Stuttgart, Stuttgart, Germany.
19. **Elvers, B., S. Hawkins, and G. Schulz.** 1991. Ullmann's Encyclopedia of Industrial Chemistry. Verlag Chemie, Weinheim.
20. **Eulberg, D., and M. Schlomann.** 1998. The putative regulator of catechol catabolism in *Rhodococcus opacus* 1CP - an IclR-type, not a LysR-type transcriptional regulator. *Antonie Van Leeuwenhoek*. **74**:71-82.
21. **Falbe, J. and M. Regitz.** 1999. Römpp Lexikon Chemie. Georg Thieme Verlag, Stuttgart, New York.
22. **Galinier, A., D. Negre, J. C. Cortay, S. Marcandier, S. R. Maloy, and A. J. Cozzone.** 1990. Sequence analysis of the *iclR* gene encoding the repressor of the acetate operon in *Salmonella typhimurium*. *Nucl. Acids Res.* **18**:3656.
23. **Galinier, A., F. Bleicher, D. Negre, G. Perriere, B. Duclos, A. J. Cozzone, and J. C. Cortay.** 1991. Primary structure of the intergenic region between *aceK* and *iclR* in the *Escherichia coli* chromosome. *Gene*. **97**:149-150.
24. **Gerischer, U., A. Segura, and L. N. Ornston.** 1998. PcaU, a transcriptional activator of genes for protocatechuate utilisation in *Acinetobacter*. *J. Bacteriol.* **180**:1512-1524.
25. **Gibson, D. T., and R. E. Parales.** 2000. Aromatic hydrocarbon dioxygenases in environmental biotechnology. *Curr. Opin. Biotechnol.* **11**:236-243.

26. **Gou, Z., and J. E. Houghton.** 1999. PcaR-mediated activation and repression of *pca* genes from *Pseudomonas putida* are propagated by its binding to both the -35 and the -10 promoter elements. *Molec. Microbiol.* **32**:253-263.
27. **Grzeszik, C., M. Lübbers, M. Reh, and H. G. Schlegel.** 1997. Genes encoding the NAD-reducing hydrogenase of *Rhodococcus opacus* MR11. *J. Microbiol.* **143**:1271-1286.
28. **Gui, L., A. Sunnarborg, B. Pan, and D. C. LaPorte.** 1996a. Autoregulation of *iclR*, the gene encoding the repressor of the glyoxylate bypass operon. *J Bacteriol.* **178**:321-324.
29. **Gui, L., A. Sunnarborg, and D. C. LaPorte.** 1996b. Regulated expression of a repressor protein: FadR activates *iclR*. *J. Bacteriol.* **178**:4704-4709.
30. **Hashimoto, Y., M. Nishiyama, F. Yu, I. Watanabe, S. Horinouchi, and T. Beppu.** 1992. Development of a host-vector system in a *Rhodococcus* strain and its use for expression of the cloned nitrile hydratase gene cluster. *J. Gen. Microbiol.* **138**:1003-1010.
31. **Heiss, G., K. W. Hofmann, N. Trachtmann, D. M. Walters, P. Rouvière, and H.-J. Knackmuss.** 2002: *npd* gene functions of *Rhodococcus (opacus) erythropolis* HL PM-1 in the initial steps of 2,4,6-trinitrophenol degradation. *Microbiology* **148**: 799-806.
32. **Heiss, G., N. Trachtmann, Y. Abe, M. Takeo, and H.-J. Knackmuss.** 2003. Homologous *npdGI* genes in 2,4-Dinitrophenol- and 4-nitrophenol-degrading *Rhodococcus* spp. *Appl. Environ. Microbiol.* **69**:2748-2754.
33. **Hofmann, K. W.** 2003. Enzymes and metabolites in picric acid (2,4,6-trinitrophenol) and 2,4-dinitrophenol biodegradation. Ph.D. thesis. University of Stuttgart, Stuttgart, Germany.

34. **Hughes, M. A. and P. A. Williams.** 2001. Cloning and characterisation of the *pnb* genes, encoding enzymes for 4-nitrobenzoate catabolism in *Pseudomonas putida* TW3. *J. Bacteriol.* **183**: 1225-1232.
35. **Inoue, H., H. Nojima, and H. Okayama.** 1990. High efficiency transformation of *Escherichia coli* with plasmids. *Gene.* **96**: 23-28.
36. **Jones, R. M., B. B. Compton, and P. A. Williams.** 2003. The naphthalene catabolic (*nag*) genes of *Ralstonia* sp. strain U2 are an operon that is regulated by NagR, a LysR-type transcriptional regulator. *J. Bacteriol.* **185**: 5847-5853.
37. **Kalkus, J., C. Dorrie, D. Fischer, M. Reh, and H. G. Schlegel.** 1993. The giant linear plasmid pHG207 from *Rhodococcus* sp. encoding hydrogen autotrophy-characterisation of the plasmid and its termini. *J. Gen. Microbiol.* **139**: 2055-2065.
38. **Kholod, N., and T. Mustelin.** 2001. Novel vectors for co-expression of two proteins in *E. coli*. *Biotechniques.* **31**:1-4.
39. **Kulakov, L. A., and M. J. Larkin.** 2002. Genetic organisation of *Rhodococcus*. In Antoine- danchin (ed.), *Genomics of GC-Rich Gram-Positive Bacteria*. Caister Academic Press.
40. **Kulakova, L. A., G. J. Poelarends, D. B. Janssen, and M. J. Larkin.** 1997. The plasmid-located haloalkane dehydrogenase gene from *Rhodococcus rhodochrous* NCIMB13064. *Microbiol.* **143**:109-115.
41. **Labbe', D., J. Garnon, and P. C. K. Lau.** 1997. Characterisation of the genes encoding a receptor-like histidine kinase and a cognate response regulator from a biphenyl/polychlorobiphenyl-degrading bacterium, *Rhodococcus* sp. strain M5. *J. Bacteriol.* **179**:2772-2776.
42. **Laemmli, U. K.** 1970. Cleavage of structure proteins during the assembly of the head of bacteriophage T4. *Nature.* **227**: 680-685.

43. **Larkin, M. J., R. D. Mot, L. A. Kulakov, and I. Nagy.** 1998. Applied aspects of *Rhodococcus* genetics. *Antonie van Leeuwenhoek* **74**: 133-153.
44. **Lenke, H.** 1990. Mikrobieller Abbau von Nitrophenolen: 2,4-dinitrophenole und 2,4,6-trinitrophenole. Ph.D. thesis. University of Stuttgart, Stuttgart, Germany.
45. **Lenke, H., D. H. Pieper, C. Bruhn, and H.-J. Knackmuss.** 1992a. Degradation of 2,4-dinitrophenol by two *Rhodococcus erythropolis* strains, HL 24-1 and HL 24-2. *Appl. Environ. Microbiol.* **58**:2928-2932.
46. **Lenke, H. and H.-J. Knackmuss.** 1992b. Initial hydrogenation during catabolism of picric acid by *Rhodococcus erythropolis* HL 24-2. *Appl. Environ. Microbiol.* **62**:784-790.
47. **Lenke, H., and H.-J. Knackmuss.** 1996. Initial hydrogenation and extensive reduction of substituted 2,4-dinitrophenols. *Appl. Environ. Microbiol.* **62**:784-790.
48. **Lessner, D. J., R. E. Parales, S. Narayan, and D. T. Gibson.** 2003. Expression of the nitroarene dioxygenase genes in *Comamonas* sp. strain JS765 and *Acidovorax* sp. strain JS42 is induced by multiple aromatic compounds. *J. Bacteriol.* **185**: 3895-3904.
49. **Luria, S. E., Adams, J. N. and R. C. Ting.** 1960. Transduction of lactose utilising ability among strains of *E. coli* and *S. dysenteriae* and the properties of the transducing phage particle. *Virology.* **12**: 348-390.
50. **Masai, E., K. Sugiyama, N. Iwashita, S. Shimizu, J. E. Hauschild, T. Hatta, K. Kimbara, K. Yano, and M. Fukuda.** 1997. The *bphDEF* meta-cleavage pathway genes involved in biphenyl/polychlorinated biphenyl degradation are located on a linear plasmid and separated from the initial *bphABC* genes in *Rhodococcus* sp. strain RHA1. *Gene.* **187**:141-149.
51. **Montgomery, H. A. C., and J. F. Dymock.** 1961. The determination of nitrite in water. *Analyst.* **86**: 414-416.

52. **Negre, D., J. C. Cortay, I. G. Old, A. Gelinier, C. Richaud, I. S. Girons, and A. J. Cozzone.** 1991. Overproduction and characterisation of the *iclR* gene product of *Escherichia coli* K-12 and comparison with that of *Salmonella typhimurium* LT2. *Gene*. **97**:29-37.
53. **Ogawara H., N. Aoyagi, M. Watanabe and H. Urabe.** 1999. Sequences and evolutionary analyses of eukaryotic-type protein kinases from *Streptomyces coelicolor* A3 (2). *J. Microbiol.* **145**: 3343-3352.
54. **Parales, J. V., A. Kumar, R. E. Parales, and D. T. Gibson.** 1996. Cloning and sequencing of the gene encoding 2-nitrotoluene dioxygenase from *Pseudomonas* sp. JS42. *Gene*. **181**: 57-61.
55. **Parales, R. E.** 2000. Molecular biology of nitroarene degradation, p 63-89. *In* J. C. Spain, J. B. Hughes, and H.-J. Knackmuss (ed.), *Biodegradation of Nitroaromatic Compounds and Explosives*. Lewis Publishers, Boca Raton.
56. **Park, H. S. and H. S. Kim.** 2001. Genetic and structural organisation of the aminophenol catabolic operon and its implication for evolutionary process. *J. Bacteriol.* **183**: 5074-5081.
57. **Pfennig, M., und K. D. Lippert.** 1966. Über das Vitamin B12-Bedürfnis phototropher Schwefelbakterien. *Archiv für Mikrobiologie.* **55**: 245-256.
58. **Prescott, J., and S. O. Tkachuk.** 1991. *Rhodococcus equi* plasmids: isolation and partial characterisation. *J. Clin. Microbiol.* **29**: 2696-2700.
59. **Prousek, J., and M. Slosarikova.** 1996. Fotokataliticka degradace 2,4,6-trinitrofenolu (kyselina pikrova) za pouziti vodnych polovodicovych disperznich smesi. *Chem. Listy.* **90**:829-832.
60. **Rajan, J., K. Valli, R. E. Perkins, F. S. Sariaslani, S. M. Barns, A. L. Reysenbach, S. Rehm, M. Ehringer, and N. R. Pace.** 1996. Mineralisation of 2,4,6-trinitrophenol

- (picric acid): characterisation and phylogenetic identification of microbial strains. *J. Ind. Microbiol.* **16**:319-324.
61. **Rieger, P. G., V. Sinnwell, A. Preuss, W. Francke, and H. J. Knackmuss.** 1999. Hydride-Meisenheimer complex formation and protonation as key reactions of 2,4,6-trinitrophenol biodegradation by *Rhodococcus erythropolis*. *J. Bacteriol.* **181**:1189-1195.
62. **Russ, R., D. M. Walter, H.-J. Knackmuss, and P. E. Rouvière.** 2000. Identification of genes involved in picric acid and 2,4-dinitrophenol degradation by mRNA differential display, p. 127-143. *In* J. C. Spain, J. B. Hughes, and H.-J. Knackmuss (ed.), *Biodegradation of Nitroaromatic Compounds and Explosives*. Lewis Publishers, Boca Raton.
63. **Sambrook, J., E. F. Fritsch, and T. Maniatis.** 1989. *Molecular cloning: a Laboratory Manual*, 2nd edn. Cold Spring Harbor, NY: Cold Spring Harbor Laboratory.
64. **Sauer, R. T., R. R. Yocum, R. F. Doolittle, M. Lewis, and C. O. Pabo.** 1982. Homology among DNA-binding proteins suggests use of a conserved super-secondary structure. *Nature (London)*. **298**:447-451.
65. **Schäfer, A., A. Tauch, W. Jäger, J. Kalinowski, G. Thierbach, and A. Pühler.** 1994. Small mobilisable multi-purpose cloning vectors derived from the *Escherichia coli* plasmids pK18 and pK19: selection of defined deletions in the chromosome of *Corynebacterium glutamicum*. *Gene*. **145**:69-73.
66. **Sharp, P. A., Sudgen, B. and J. Sambrook.** 1973. Detection of two restriction endonuclease activities in *Haemophilus parainfluenzae* using analytical agarose ethidium bromide electrophoresis. *Biochemistry*. **12**:3055-3063.

67. **Shin S., S. G. Song, D. S. Lee, J. G. Pan, and C. Park.** 1997. Involvement of *iclR* and *rpoS* in the induction of *acs*, the genes for acetyl coenzyme A synthetase of *Escherichia coli* K-12. FEMS Microbiol. Letter. **146**:103-108.
68. **Simon, R., U. Priefer, and A. Pühler.** 1983. A broad host range mobilisation system for *in vivo* genetic engineering: transposon mutagenesis in Gram negative bacteria. Bio/technology **1**:784-791.
69. **Spain, J. C., J. B. Hughes, and H. J. Knackmuss.** 2000. Biodegradation of nitroaromatic compounds and explosives. Lewis Publisher, Boca Raton, Fla.
70. **Strohl, W. R.** 1992. Compilation and analysis of DNA sequences associated with apparent streptomycete promoters. Nucleic. Acids. Research. **20**:961-974.
71. **Suen, W. C., and J. C. Spain.** 1993. Cloning and characterisation of *Pseudomonas* sp. strain DNT genes for 2,4-dinitrotoluene degradation. J. Bacteriol. **175**: 1831-1837.
72. **Sunnarborg, A., D. Klumpp, T. Chung, and D. C. Laporte.** 1990. Regulation of the glyoxylate bypass operon: cloning and characterisation of *iclR*. J. Bacteriol. **172**:2642-2649.
73. **Takeda, H., A. Yamada., K. Miyauchi, E. Masai, and M. Fukuda.** 2004. Characterisation of transcriptional regulatory genes for biphenyl degradation in *Rhodococcus* sp. strain RHA1. J. Bacteriol. **186**:2134-2146.
74. **Tatusova, T. A., and T. L. Madden.** 1999. BLAST 2 Sequences, a new tool for comparing protein and nucleotide sequences. FEMS Microbiol. Lett. **174**:247-250.
75. **Thompson, J. D., D. G. Higgins, and T. J. Gibson.** 1994. CLUSTAL W: improving the sensitivity of progressive multiple sequence alignment through sequence weighting, position-specific gap penalties and weight matrix choice. Nucl. Acids Res. **22**:4673-4680.

76. **Trautwein, G., and U. Gerischer.** 2001. Effects exerted by transcriptional regulator PcaU from *Acinetobacter* sp. strain ADP1. *J. Bacteriol.* **183**:873-881.
77. **van der Geize, R., G. I. Hessels, R. van Gerwen, P. van der Meijden, and L. Dijkhuizen.** 2001. Unmarked gene deletion mutagenesis of *kstD*, encoding 3-ketosteroid α -dehydrogenase, in *Rhodococcus erythropolis* SQ1 using *sacB* as counter-selectable marker. *FEMS Microbiol. Lett.* **205**:197-202.
78. **Vorbeck, C., H. Lenke, P. Fischer, and H.-J. Knackmuss.** 1994. Identification of a hydride-Meisenheimer complex as a metabolite of 2,4,6-trinitrotoluene by a *Mycobacterium* strain. *J. Bacteriol.* **176**:932-934.
79. **Vorbeck, C., H. Lenke, P. Fischer, J. C. Spain, and H.-J. Knackmuss.** 1998. Initial reductive reactions in anaerobic microbial metabolism of 2,4,6-trinitrotoluene (TNT). *Appl. Environ. Microbiol.* **64**:246-252.
80. **Walters, D. M., R. Russ, H.-J. Knackmuss, and P. E. Rouvière.** 2001. High-density sampling of a bacterial operon using mRNA differential display. *Gene* **273**:305-315.
81. **Witte, C.-P., R. Blasco, and F. Castillo.** 1998. Microbial photodegradation of aminoarenes. Metabolism of 2-amino-4-nitrophenol by *Rhodobacter capsulatus*. *Appl. Biochem. Biotechnol.* **69**:191-202.
82. **Wyman, J. F., M. P. Serve, D. W. Hobson, L. H. Lee, and D. E. Uddin.** 1992. Acute toxicity, distribution, and metabolism of 2,4,6-trinitrophenol (picric acid) in Fischer 344 rats. *J. Toxicol. Environ. Health.* **37**:313-327.
83. **Yudkin, M. D.,** 1988. The prediction of helix-turn-helix DNA-binding regions in proteins. *Protein Eng.* **1**:371-372.
84. **Zhou, N. Y., S. L. Fuenmayor, and P. A. Williams.** 2001. *nag* genes of *Ralstonia* (formerly *Pseudomonas*) sp. strain U2 encoding enzymes for gentisate catabolism. *J. Bacteriol.* **183**: 700-708.

85. **Zylstra, G. J., S. W. Bang, L. M. Newman, and L. L. Perry.** 2000. Microbial degradation of mononitrophenols and mononitrobenzoates. p 145-160. *In* J. C. Spain, J. B. Hughes, and H.-J. Knackmuss (ed.), *Biodegradation of Nitroaromatic Compounds and Explosives*. Lewis Publishers, Boca Raton.

Acknowledgement

I would like to sincerely thank Prof. Dr. Hans-Joachim Knackmuss for supporting me and for evaluating this work.

I am very grateful to Dr. Gesche Heiss for giving me the opportunity to do this work in Germany, for supervising me and for very helpful discussions.

I would like to sincerely thank Prof. Dr. Georg Sprenger for his suggestions and evaluating this work.

I extend my appreciation to Dr. Josef Altenbuchner for the gift of bacterial strains and plasmids and for contributing his knowledge in this work.

I would like to thank my co-workers in the lab, Klaus Hofmann, Natali Trachtmann, Ana Rebic for encouraging me during difficult time and for helping in the lab.

I would like to express my appreciation to Iris Fisher for showing me techniques and giving me helpful advices from her own experiences.

I sincerely thank all my colleagues in Institute for Microbiology for a nice working atmosphere and for helping me along in three years.

Especially, I would like to thank my husband, who always supports me and take cares of me with all his love.

Curriculum Vitae

Dang Phuong Nga

Born on 18th May, 1973, in Hanoi, Vietnam

- 1990-1994 Studied Biology, at Vietnam National University
- 7/1993 Began experimental research with Dr. Lai Thuy Hien at Department of Petroleum Microbiology, Institute for Biotechnology, National Centre for Natural Sciences and Technologies
- 9/1994 Received B.Sc. degree
Subject: Characterisation of some sulphate-reducing bacteria isolated from Vungtau oil wells
- 4/1995-4/1996 Worked as researcher at Lab. of Microbiology, Institute for Genetics and General Microbiology. Salzburg, Austria
- 5/1996 Worked as researcher at Department of Petroleum Microbiology, Institute for Biotechnology, National centre for Natural Sciences and Technologies
- 7/2000 Received Master degree
Subject: Characterisation of some acquainted bacteria in JetA1 aircraft fuel and their effects on quality of petroleum products
- 9/2000 Began PhD research with Prof. H.-J. Knackmuss at Institute for Microbiology, University Stuttgart