

Investigation on the potential of individual blade control for lifetime extension

Vasilis Pettas, Mohammad Salari, David Schlipf and Po Wen Cheng

Stuttgart Wind Energy at University of Stuttgart, Allmandring 5B, 70569 Stuttgart, Germany

E-mail: pettas@ifb.uni-stuttgart.de

Abstract. In recent years the focus of wind energy industry is on reducing levelized cost of energy by rotor upscaling. Moreover, a current topic of interest to both industry and academia is the extension of lifetime to existing wind turbines approaching the end of initial design span. Thus, the need for load alleviation technologies integrated in the design process or for retrofit purposes is becoming more relevant. One of these is individual blade pitch control, a recurring topic in research, with known advantages and weaknesses namely the pitch actuator and bearing wear. The present work suggests such a system incorporating three independent controllers with input the root bending moments on the rotating frame. The linear system used for controller design is based on black box identification of non-linear simulations and filters are used both for the input and output. Different setups of the independent blade control scheme are applied on a 10 MW reference turbine, with a large and highly flexible rotor representative of the current industrial status, under wind conditions as defined by relevant certification standards. The investigation aims on evaluating the system's performance based on the fatigue load alleviation potential for different components as well as identifying the tradeoff for each design choice. Finally, based on basic assumptions the reductions are translated to possible life time extension for each component based on a combined operation where the new controllers are applied for a percentage of the initial 20 year lifetime.

1. Introduction

The ongoing rapid growth in wind turbine rotor size leads to higher loads requiring more advanced load alleviation techniques. Active and passive technologies could be major enablers in order to keep up this growth rate. Active control technologies [1] like individual pitch control (IPC) and smart rotors are more attractive since they offer more design freedom to load alleviation for different components. Furthermore, the life time extension possibilities for existing turbines is of high interest as installed capacity is increased and more projects are coming close to the end of design life [2], while new standards are being published for certification purposes [3] and major manufacturers already offer such service packages. Lifetime extension can be more profitable, especially in the short term, compared to other options like re-powering. Using IPC as a retrofit in older turbines can be an attractive option in this direction. Most turbines already include individual pitch actuators, while sensors like strain gauges or fiber-optical gratings for the blade root loads are becoming cheaper and more reliable. Depending on the estimated remaining fatigue reserve of the different components the load alleviation from an updated controller with IPC, including possibly de-rating of the turbine, is a potential enabler for prolonging life time.



IPC methods with a variety of approaches have been extensively researched in wind energy. An overview of the different concepts for individual pitch along with their fundamental differences and similarities can be found in [4]. The most common approach is using the Coleman transformation of the rotating frame moments to the inertial frame producing cyclic pitch targeting loads up to 1P (1 per revolution) bandwidth [5], while further investigations for higher harmonic control have been carried out [6]. Other more advanced approaches using feedback-feedforward control with multivariable LQG control [7] and feedforward with DAC [8] have been also investigated. Moreover, active control methods like trailing edge flaps have been combined and compared to IPC showing the differences and combined potential [9], [10]. The evaluation of these methods in terms of actuator damage and other performance tradeoffs, as in [11], has been less thoroughly investigated, although a critical point for industrial implementation. The potential of using the individual blade moment as a single input single output (SISO) controller resulting in three parallel and independent, individual blade controllers (IBC) is another concept with advantages and shortcomings that has been less investigated so far. IBC using inflow measurements [12] and blade root measurements [13] have been also presented showing the effect on fatigue and extreme loads.

The scope of the present work is to propose an IBC approach using measured flapwise bending moments while investigating the trade-offs between load reduction and pitch system actuation and other metrics on a full design basis, giving an insight on the potential and limitations for application on large utility scale turbines. The black-box identification of a linear blade model having as inputs the blade pitch and a reference blade effective wind speed is explained. The implementation of the controller is then shown along with different setups and design parameters. Results of simulations with the DTU 10 MW reference turbine [14] including DLC1.2 class IA conditions as indicated by IEC standard 61-400 ed. 3 [15] using the high fidelity aeroelastic code FAST [16] are presented. The load reductions and metrics are assessed for the whole lifetime as well as a combined lifetime, where the turbine is operating for some years with the baseline collective pitch controller (CPC) and for the rest with the suggested IBC controllers. The resulting damage reductions per component are interpreted, based on some assumptions, to possible years of lifetime extension and relevant shortcomings are discussed.

2. Methodology

The IBC approach compared to the traditional Coleman transformation [17], commonly used in IPC, allows more freedom to controller design both in terms of inputs and outputs. Transforming the moments from the rotating to the inertial frame inherently rejects the higher frequencies than 1P, giving a low frequency measure of the rotor unbalance in the form of yaw and tilt collective rotor moments along with a 0P component. The output of such an implementation is then a cyclic, azimuth dependent, pitch command canceling out the rotor imbalance. The main benefit of this transformation is the removal of the periodical component making the derivation and tuning of the controller based on an linear time invariant (LTI) system easier. The drawback is the limitation in targeting frequencies and it can be seen as loss of information about the blade state. The rotating frame input provides all the frequencies affecting the blade response and allows to act instantaneously and independently on the different conditions that each blade experiences with the cost of higher pitch actuation. The control system can target different frequencies, which in turn can focus on load alleviation of different components. The main challenges in this approach is the identification of such a system with periodical characteristics and the limitation of pitch actuation to the meaningful, for load alleviation of different components, bandwidth.

2.1. Linear model identification

The rotor's properties, weight, coning, tilting and overhang, produce a deterministic loading while the temporal and spatial discretization of turbulent wind, including shear effects, produce stochastic loading. Their coupling depends on the non-linear structural response of the turbine and the operating point. In bibliography, different simplified modeling concepts for controller design have been suggested based on physical second order mass spring damper systems like e.g. in [10] or gray models introducing fictitious forces [13]. In the present work, the blade model is completely decoupled from the rest of the turbine. The flapwise bending moment was selected as the reference signal instead of out of plane or other combination of flapwise and edgewise moments as it is considered more sensitive to fatigue load due to the blades shape, nevertheless the same method can be applied with any input. Using black box identification methods, more precisely the n4sid algorithm for subspace state space system identification [18] using the Canonical Variable Algorithm (CVA) [19], a LTI state-space model is obtained. This approach with a non-physical model was preferred in an attempt to capture higher harmonics with the identified model.

The transfer function from inputs, pitch and blade effective wind speed, to output flapwise bending moment is identified based on closed loop, full flexible model and rotor geometry, non-linear simulations with low intensity turbulent fields. The required turbulence intensity (TI) was identified by a sensitivity analysis, since it had to be high enough to excite the relevant frequencies and low enough to stay as close as possible to the required operating point. This approach has the benefit of capturing the non-linear structural behavior of the blade including also the actuator and baseline PI pitch controller implicitly, as their effects are included in the identification dataset. The calculation of blade effective wind speed, modeling the rotational sampling of turbulence by the blades, uses azimuth discretized and spanwise averaged wind speeds, taking into account instantaneous blade azimuth and tower top structural motion. The number of points and the weighting average along the blade were obtained by parametric tests with the metric being the agreement with the non-linear model in terms of input-to-output comparisons. The whole procedure was executed iteratively where a 1 hour windfield with 5% TI was used for identification and another one, with same TI but different seed, used for validation. The models for every wind speed were assessed based on time and frequency domain convergence. In this manner, a linear model around each operating point presenting excitation to the relevant blade frequencies as well as capturing the coupling of wind and pitch to moment, is obtained. The resulting fifth order LTI systems fit the FAST simulations up to 3P (0.48 Hz) as shown in figure 1. The resulting Variance Accounted For (VAF) was calculated in a level of 65% for all speeds.

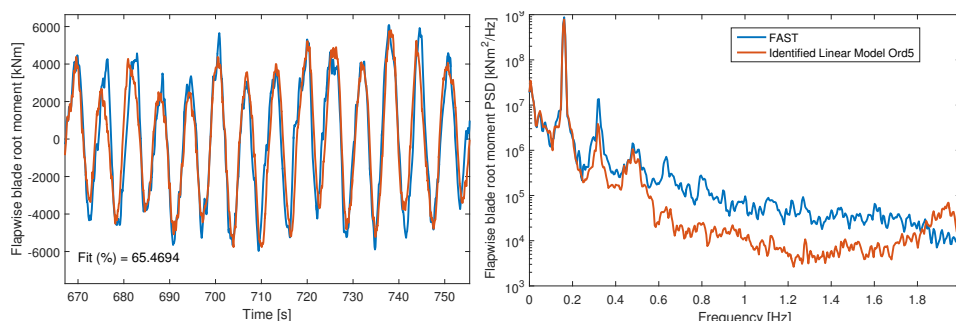

Figure 1. Identified linear model and FAST simulation response around 16 m/s with 5% turbulence intensity

2.2. Controller structure

The IBC controller will be used as an add-on to the existing baseline PI CPC controller without retuning, since in the present study the effectiveness of IBC is examined. It is intended to compensate the disturbances in blade root moments but not to regulate the operating point. Therefore, the $\Delta\theta$ contribution in pitch demand of each SISO IBC is summed with that of the baseline CPC controller which regulates the generator speed. In order to avoid changing the power performance, IBC is active only in above-rated conditions. The switching between regions is done based on the generator power signal where the IBC outputs are scaled with a factor varying linearly between 0 and 1 for power between 90% and 100% of rated. This strategy ensures smooth transitioning while minimizing power losses and enhancing load alleviation as seen in the results section. Moreover, the gains of the controller, similarly to the traditional CPC controllers, are scheduled based on the collective pitch values in order to compensate for the non-linear dynamics and different effect of pitch in different wind speeds. The control scheme itself is a traditional linear feedback structure due to the simplicity, robustness and effectiveness. A simple, although maybe not optimal, control design is more likely to be adopted by the industry while making it easier to apply online adaptive techniques for periodical re-tuning. Another important part of the controller design is the combination of the filters used for the input blade root bending moment and for the output pitch regulating the effective bandwidth of the controller. Hence, the parameters defining the controller's behavior are the frequencies of the high pass (HP) and band stop (BS) filters as well as the tuning of the controller itself. The schematic diagram of the control system is presented in figure 2.

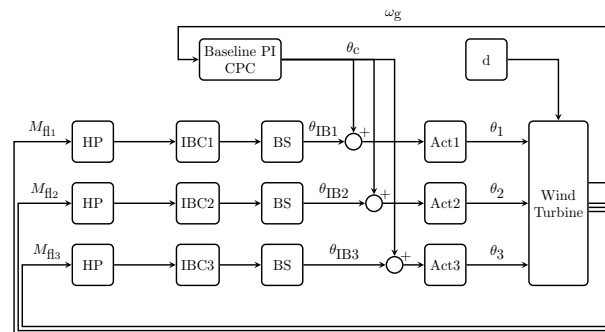

Figure 2. Schematic diagram of the individual blade controller system

2.3. Filter design

The input to the controller is high pass (HP) filtered flapwise moment, in order to avoid the compensation of frequencies close to 0P and part of the deterministic loading. A first order HP filter is used and the corner frequency was tested together with the gains, since they are coupled. The value used was 0.05 Hz. The output of the controller is BS filtered limiting the targeting frequencies. Since the effect of different control bandwidths to load alleviation and pitch actuation is investigated, the purpose of the filters is to exclude specific frequency ranges with the minimum effect on the rest of the bandwidth. Several setups were tested with implementation of different order low pass and Butterworth notch filters but the inherent delays and ripple showed to be detrimental for load reduction. In order to avoid these effects, 3 degree of freedom (DOF) notch filters were implemented in series. This way specific frequencies can be targeted while regulating the phase response close to these frequencies. Notch filters with parameters Q_{width} , Q_{depth} and ω_n regulating the width, depth and natural frequency respectively

were implemented with the transfer function shown in equation 1.

$$Notch_{3DOF} = \frac{s^2 + sQ_{width}Q_{depth} + \omega_n^2}{s^2 + sQ_{width} + \omega_n^2} \quad (1)$$

These 3DOF notch filters were designed separately from the controller according to the targeted frequencies. The goal was to be able to exclude the region of 2P and 3P, which was observed to be dominant in the blade and pitch spectra. Moreover, the attenuation of higher frequencies was considered which, at least for the blade root moments, did not contribute significantly to load alleviation but increased highly the pitch actuation. Multiple in series filters were chosen over one combining-all, due to the aforementioned delays. The parameters of the filters were manually tuned for each case with targeted frequencies 0.32Hz (2P), 0.48Hz (3P), 0.9Hz and 1.5Hz. Bandwidth higher than 2Hz is out of the system's operational envelope and was not considered. The bode plots of the implemented filters are shown in figure 3.

2.4. Controller tuning

The feedback control for this system has some specific characteristics. The input values are zero mean (due to the HP) and the set point is always zero, i.e. the measured process variable is always the error. Moreover, the possible contribution of the IBC should be small, a few degrees, since we do not want to change the operating point and interfere with the baseline CPC controller while the bandwidth is bounded by the systems relevant frequencies, which in the present case are below 2Hz. Thus, an integral part is not useful as it creates an offset and counteracts the HP filtering. The derivative part is partially substituted by the HP but also commonly avoided on measurement signals with noise in order to avoid amplification. Hence, the tuning problem is reduced to identifying an optimal proportional gain for each operating point. This is done with open loop shaping, where the identified linear state space model from pitch to blade moment is used. The gain is pushed until the phase and gain margins reach a certain threshold (5 dB and 40 deg), which is a measure of the robustness of the linear controller. The open loop system presented non-minimum phase behavior, having a zero in the right half plane, which restricts the possible effective bandwidth and gain increase. Starting with these as initial values, further gain increase was investigated manually with non-linear simulations in order to obtain the optimal gain per operating point. Finally, it is noted that the filter parameters were kept constant for all operating points since no added benefit was found by scheduling both gains and filter parameters.

The only control input is the flapwise bending root moment, which means that the other loads can only be implicitly affected by the complex dynamic structural coupling of the wind turbine system. By identifying an effective, or even optimal, control setup for blade load reduction, acting only on the spectrum excited by the blades, the only tunable parameter correlated to the other components is the control bandwidth limitation. Therefore, three different controllers were created with different setup in the output filters. The first, denoted as 'IBC 1P' in the following sections, includes all the filters combined in series focusing the IBC bandwidth up to 1P, the second 'IBC 1P+2P+3P' uses the two higher frequency notch filters targeting frequencies up to 3P and the third 'IBC all' where no frequency is suppressed.

3. Results

The three controllers are evaluated in turbulent, non-linear simulations using FAST v8 code [16] where the fully flexible DTU 10MW turbine model is used. The baseline CPC is a traditional controller for variable speed pitch regulated turbines with PI feedback for pitch and gain scheduling over pitch angle without any additional tower or drivetrain damping loops. The structural solver ElastoDyn, based on modal dynamics, is used along with AeroDyn v14 for

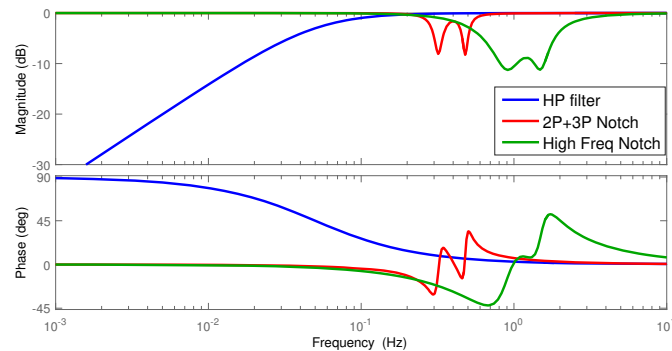

Figure 3. Filter Design for IPC

unsteady aerodynamics with the dynamic stall model activated. The pitch actuator is modeled as a second order filter with natural frequency of 1.6 Hz and damping factor 0.8, including a saturation limit for pitch rate of 8 deg/s. The simulations are performed according to class IA, DLC 1.2 [15] conditions. In total 11 speed bins (4:24 m/s) are considered, with 3 cases of yaw misalignment -10, 0 and 10 deg and different turbulence seed for each 1 hour simulation. The Damage Equivalent Loads (DEL) presented are calculated based on the Palmgren-Miner's rule [20] using the rainflow algorithm for counting the load cycles. The Wohler coefficient is set to 4 for all components except the blades where, for composites, 10 is used. The reference number of load cycles is set to 10^7 and the baseline design lifetime is considered 20 years. The lifetime calculations are done including the weighting dictated by the wind speed distribution of class Ia and the yaw misalignment cases. Finally, all the relative quantities presented in this section are calculated with equation 2.

$$Q_{rel} = 100 \frac{Q_{new} - Q_{base}}{Q_{base}} [\%] \quad (2)$$

The correlation between the controller bandwidth and fatigue loads of different components as well as the influence on pitch system and turbine performance is investigated. In order to have an overview of the whole system's response, the following loads are considered: blade root flapwise and edgewise moments and torsion (BldFW, BldEW, BldTor), tower base fore-aft and side to side moments and torsion (TwrFA, TwrBSS, TwrBTOR), tower top/yaw bearing non-rotating pitch, yaw and roll moments (TTpitch, TTYaw, TTroll) and low speed shaft torsion (LSSTor). The metrics defined for the pitch actuator include: standard deviation of pitch rate and acceleration ($\dot{\theta}, \ddot{\theta}$), and total pitch travel (θ). The metrics relevant to the turbine's performance are: produced energy (E), standard deviation of generator speed (ω_g), generator torque (Gen Trq) and power, and finally the minimum blade tip clearance from the tower (TipClr). Initially, the results are discussed per wind speed and cumulatively for the total lifetime investigating the performance of the controller. In the next section the possible contribution to lifetime extension as retrofit implementation is discussed.

3.1. Controller performance

In figure 4 the power spectral density (PSD) of $\dot{\theta}$ and blade root moment from a simulation at 16 m/s are plotted showing the different behavior of the three controllers. Linear plot is used for $\dot{\theta}$, since the area in this type of plot is the variance of the quantity. It is shown that the higher the control bandwidth the higher the pitch actuation. Especially when the higher frequencies are not attenuated the increase is substantial as seen from the 'IBC all' case. The

filters effectively reduce this but on the other hand more energy is present in the blade root spectra when these frequencies are suppressed. Moreover, the blade root spectra show that the higher energy is concentrated around 1P, 2P and 3P peaks, which contribute the most to blade loading. It is also observed that IBC increases slightly the energy in higher frequencies. The latter is attributed to the non-ideal filters affecting more frequencies and to the increased blade structural excitation.

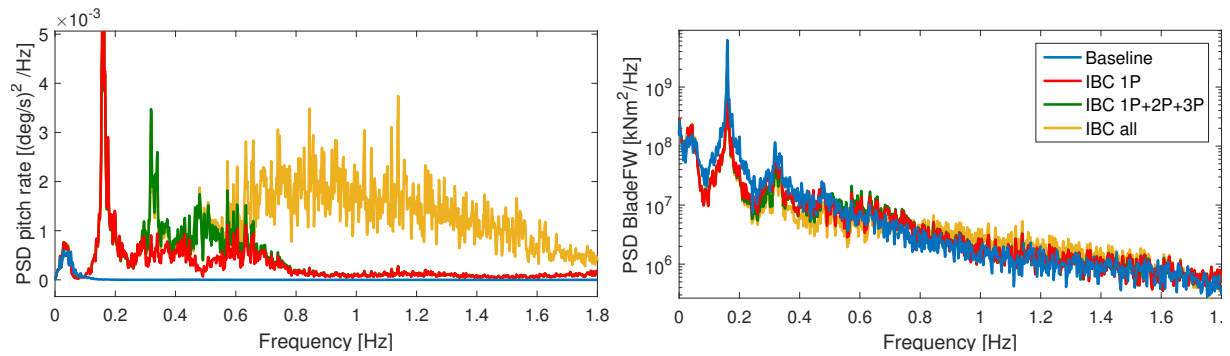

Figure 4. Blade root flapwise moment and pitch rate PSD at 16 m/s

The comparison of DEL and pitch metrics per wind speed bin is presented in figure 5. The trend of DEL magnitude per bin combined with the speed probability distribution of the turbine class shows the potential of IBC or similar methods. Channels with higher loads in higher speeds favor load reduction with techniques focusing on above rated region as seen in e.g. BladeFW and TwrSS channels. It should also be noted that class I conditions are the most favorable for load reduction, since the probability of wind speeds above rated is higher. Regarding the effectiveness of the suggested controllers, the significantly affected channels BladeFW, TwrBFAM, TwrBTOR, TTpitch and TTyaw follow the same trend where the load reduction increases with wind speeds but also with control bandwidth. The least affected channels don't change pattern over wind speeds, with all controllers showing similar results apart from BladeEW. There, the higher control bandwidth actually increases the loads at speeds over 16 m/s, which is attributed to the excitation of the first edgewise structural mode of the blade at 0.96 Hz. Pitch metrics show clearly how the higher frequencies contribute the most to pitch actuator usage, while the difference between only 1P and up to 3P bandwidth is low and constant over wind speeds.

From a system's engineering point of view the lifetime design DELs and metrics are more relevant and presented in tables 1 and 2 respectively. As expected, the maximum load reduction is found at BldFW, where all the controllers present similar results with a reduction up to 16.8% verifying that frequencies up to 1P are the dominant loading contributors. Nacelle TTpitch, TTyaw and tower TwrTOR loads present significant reduction from 6 to 11%, increasing substantially with control bandwidth. This appears to be the most important benefit of higher-than-3P control bandwidth for IBC. The tower channels TwrSS and TwrFA are also reduced up to 6.9% and 3.9% respectively, with the increasing control bandwidth having a smaller contribution. These two loads are driven by the excitation of the first tower eigen-frequency, which is not targeted by the IBC since it is not present in the input blade signal, bounding load mitigation. Tower torsion load on the other hand, dominated by the related 3P frequency, can be more effectively targeted. The blade edgewise load is influenced mainly by the aerodynamic torque and gravity, while presenting low aerodynamic damping. Thus it is not suitable as IBC objective. Tower top roll load is highly influenced by the tower response and to a smaller extend

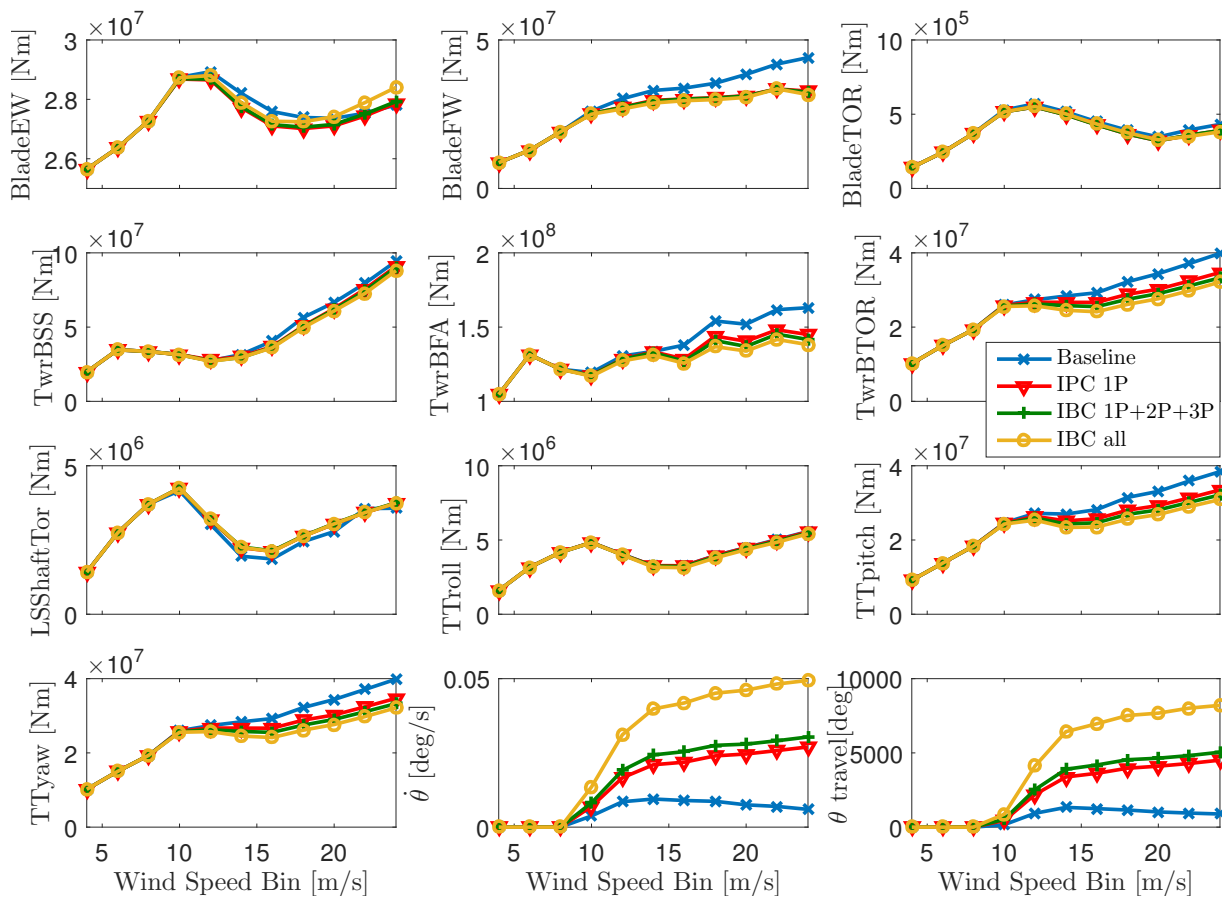

Figure 5. Absolute DEL and metrics per speed bin comparison

by the 3P region, explaining why the reduction magnitude is in general very low but with large relative difference between the cases. The low speed shaft loading, as well as generator speed and torque, depend mainly on the aerodynamic torque variations which combined with the rotor's inertia are in the low frequency spectrum, regulated by the CPC. Therefore, due to the small interference of IBC, LssTor load inevitably increases by 2% as well as generator torque and speed standard deviations, irrespectively of the control bandwidth.

Table 1. Lifetime DEL relative difference (%) compared to baseline for DLC 1.2 class IA

Controller	BldEW	BldFW	BldTOR	TwrBSS	TwrBFA	TwrBTOR	LSSTor	TTroll	TTPitch	TTYaw
IBC 1P	-0.7	-15.1	-3.3	-4.7	-2.5	-6.0	2.0	-0.05	-6.3	-6.0
IBC 1-3P	-0.6	-15.5	-3.4	-5.6	-3.1	-8.4	2.2	-0.48	-8.5	-8.3
IBC all	-0.3	-16.8	-2.9	-6.9	-3.9	-11.0	2.2	-0.98	-10.9	-10.9

The pitch actuation and turbine performance metrics for the total lifetime are presented in table 2. The pitch actuator metrics along with table 1 show the trade off between loads and actuator usage as well as the correlation between actuator usage and control bandwidth. The 'IBC 1P' and 'IBC 1-3P' cases present similar behavior with pitch travel and rate std showing

an increase up to 230% and 160%, while the acceleration std exhibits the highest increase up to 770%. For 'IBC all' the increase is doubled for all metrics compared to the other cases making the higher load reduction in limited components very expensive. Additionally, it is noted that the pitch rate saturation limit was not reached in any case. Finally, the blade root load reductions discussed earlier are beneficial for the blade bearings as they indicate decreased loading on the rotating elements.

The impact on energy production is minimal in all cases with the maximum reduction being 0.05%. Similarly, the standard deviation of power, a measure of the produced energy quality, is increased less than 0.3% for all cases, verifying the decoupling of IBC to baseline CPC. It is worth mentioning that the CPC operates in constant power mode which favors power quality over loads. Regarding the metrics relevant to the generator, an increase up to 2% and 4% is observed at the standard deviation of torque and speed as explained. These metrics can be influenced further by the region switching strategy where a more aggressive approach benefits load reduction. Minimum tip clearance is also a common design driver for modern large rotor blades. It is shown that IBC marginally increases it by 2%, although other DLCs like gust or fault cases need to be checked. In general, the performance metrics are practically unaffected by IBC and its bandwidth. Moreover, in the present study, perfect measurements of the blade moments are assumed which is not valid for a real system. The measurement noise, usually high frequency, is expected to affect both load reduction and turbine metrics with the effect increasing with the controller's bandwidth.

Table 2. Lifetime metrics relative difference (%) compared to baseline for DLC 1.2 class IA

Controller	Pitch Travel	Pitch rate std	Pitch acc std	Energy	Power std	Gen Trq std	Gen Sp std	TipClr
IBC 1P	187.6	131.1	739.7	-0.04	0.23	1.93	4.00	2.15
IBC 1-3P	230.1	166.5	776.9	-0.04	0.25	1.98	4.14	2.41
IBC all	444.5	337.0	1674.8	-0.05	0.26	2.08	4.39	2.52

Results can be compared to similar investigations in literature. In [10] a 7.5 MW reference turbine with an H_∞ IBC targeting 1P loads is simulated for class Ia conditions. The trend and magnitude of lifetime DEL reduction is similar for the blade channels while tower and tower top loads are only negatively affected. Moreover, in [13] different linear feedback IBC, with dynamic variation of the input combination of blade moments, designs with 1P and 2P bandwidth are investigated on a 5MW exemplar turbine, while the wind conditions are not stated. The load reduction envelope agrees except for the TwrFA case which is unaffected. Although the turbine model and control setup are different the results converge on which loads are benefited by the increased control bandwidth. In [11] a feedback IBC controller is designed for a 5 MW turbine, targeting 1P frequencies and is simulated at 18 m/s with class B turbulence (lower). The load reductions for tower top and blade are very close, with a divergence observed in TwrFA moment where the reduction reaches 30%, while present results suggest 10%. Furthermore, the presented pitch metrics show the same order of increase apart from std of $\ddot{\theta}$ which is in the level of 500% compared to 700% here which could be a result of the different actuator modeling and TI. The metrics are also compared with a traditional cyclic IPC, showing that the blade DEL reduction is higher with the cyclic approach but the tower loads are not influenced, while less reduction is seen in hub and tower top loads. The pitch metrics showed that cyclic pitch produces 10% less increase in travel and rate std, while the increase in acceleration std is less than half. This comparison demonstrates the similarities and differences of different IPC implementations but also highlights that performance is highly dependent to the specific turbine design and wind

conditions.

3.2. Lifetime extension considerations

The load reduction potential and drawbacks of individual pitch have been explored thoroughly. Nevertheless, manufacturers have been reluctant to implement in commercial turbine designs despite the steep increase in rotor sizes, showing that so far the cost of improved actuators and bearings outweighs the load reduction benefits in the LCOE calculation. The idea of lifetime extension enhancement using IBC as a retrofit, introduced here can be a new field of application. In this context, an operating turbine is considered where after a percentage of its design life, the new method is implemented as a software change along with the required pitch system refurbishment. The upgraded pitch system operating for a smaller period compared to the whole lifetime could translate to cost reduction. Additional financial benefits can be considered, although the present study focuses on the technical feasibility of the suggested business case. Thus, an example case is examined where the turbine operates for 75% of design lifetime with the baseline CPC.

The damage for the different components is calculated based on DELs for the design lifetime of 20 years for the baseline CPC and for the combined operation with 5 years of IPC. The difference between the two cases, the damage margin, is used for estimating the possible lifetime extension in years. Since some information is missing, some basic assumptions are needed for these calculations. Only fatigue loads are considered as drivers assuming that extreme loads are not changed with IBC. Then, the main assumption is on the calculation of reference baseline damage. Components have different design drivers that are not known. Thus, we assume that all are critically designed and purely fatigue driven. Furthermore, no additional fatigue reserve or deficit is considered due to mismatch between design loads and actual measured loads. Hence, present calculations is a very conservative 'worst case' scenario, considering the damage for all lifetime DELs calculated with the baseline CPC equal to 1. Based on Miner's linear damage hypothesis [20] the damage after 20 years with the combined control can be calculated with equation 3. Where $DEL_{life,IBC}$, $DEL_{life,base}$ and m are the 20 year DELs with IBC only, CPC only and the Wohler coefficient respectively.

$$D_{comb} = \frac{T_{base}}{T_{lifetime}} + \frac{T_{IBC}}{T_{lifetime}} \left(\frac{DEL_{life,IBC}}{DEL_{life,base}} \right)^m \quad (3)$$

The accumulated damage for each load after 20 years is shown in figure 6. Despite the rough assumptions and the more detailed calculations required to extract useful information on component design level the presented damage reductions are indicative of the IBC potential. The pitch actuator and performance metrics are shown in figure 7. Regarding the pitch metrics, the huge difference with the values from table 2 is apparent. Although, these are only indicators and the lack of a damage metric does not allow to quantify whether this amount of increase is acceptable. The limited literature on the topic suggests that a combination of these metrics with the blade root moments and forces is needed but also details on the technical specifications of the components are required [21]. The total energy production is less than 0.01% decreased for all cases, showing no impact to the initially expected revenue. The generator metrics are also only marginally increased.

The possible period of extension per load can be calculated based on the damage margin, assuming that damage contribution is equally distributed over years, using equation 4.

$$\frac{D_{margin}}{D_{life,IBC}} = \frac{T_{ext}}{T_{lifetime}} \Rightarrow T_{ext} = D_{margin} T_{lifetime} \left(\frac{DEL_{life,IBC}}{DEL_{life,base}} \right)^{-m} \quad (4)$$

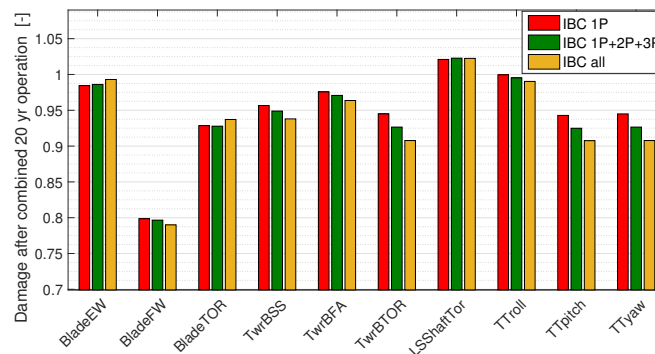

Figure 6. Accumulated damage after 20 years combined operation with 5 years IBC

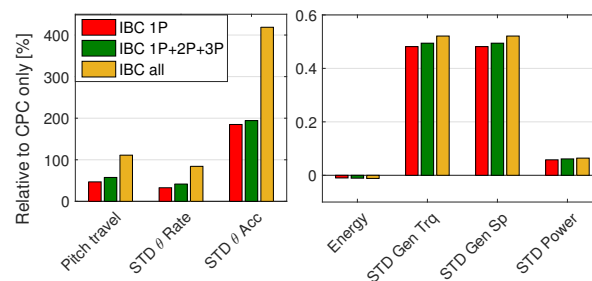

Figure 7. Metrics after 20 years combined operation with 5 years IBC

The extension in years per load is shown in figure 8. The extreme values calculated for the blade flapwise load shows the effect of the material where for a very steep S-N curve, a smaller DEL reduction translates to large lifetime extension. These values is a rough attempt to quantify the contribution of IBC in lifetime extension showing that there is some potential while more specific system’s engineering evaluation framework is needed.

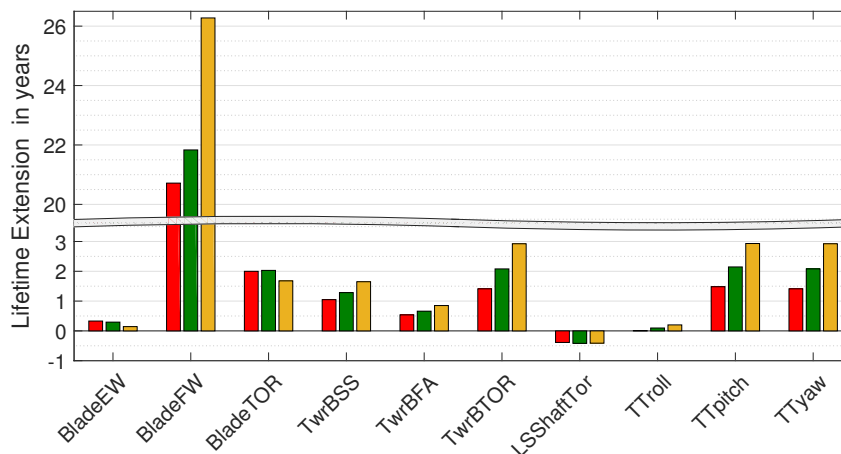

Figure 8. Lifetime extension in years after 20 years combined operation with 5 years IBC

4. Conclusions and future work

IPC is a technology that although known and researched for many years has not been applied commercially mainly due to its high impact on the pitch actuation system. In the context of life time extension, IPC as a retrofit technology could be an enabler since no new sensors or actuators are required. The present work introduces a new IPC design and investigates the load alleviation potential and drawbacks in a full design load basis. Moreover a retrofit business case for lifetime extension is suggested and evaluated.

Three independent SISO controllers are implemented using the measured flapwise blade root moment as input in an IBC structure. Decoupling from the main controller is done using high pass filters and black-box identified models are used for tuning the simple feedback structure. The effective control bandwidth is defined by a combination of filters. Three filter configurations are investigated with increasing bandwidth, identifying the trade-off between load alleviation and pitch actuation on a 10 MW turbine.

The results show that higher reduction is achieved on flapwise blade root moments, tower bottom torsion and side-to-side moments, and tower top pitch and yaw non-rotating loads. Higher than 3P control bandwidth benefits only the tower top and to a smaller extent the tower channels but comes with a very high price on pitch actuation. Low speed shaft torque, tower top roll, blade torsion and edgewise moments cannot be effectively targeted with this method since they are excited in frequencies not captured by the controlled signal. The difference between 1P and up to 3P control bandwidth is small both in load reduction and pitch actuation. Other metrics show that IBC does not have any negative effect on energy production, power fluctuation, generator speed and torque and tip-tower clearance. The main drawback is the increase in pitch actuation and especially the standard deviation of acceleration. The performance agrees with other control designs found in literature with the main benefit of IBC compared to cyclic pitch being the wider range of targeted loads and design flexibility due to more information in the control signal which, in turn, inherently introduces higher pitch demands. Moreover, the magnitude of reduction and the possible targeted loads depend highly on the aero-servo-elastic design of the turbine and the considered wind conditions.

The business case results show how the accumulated damage and metrics change after the nominal 20 years of operation where for the last 5 the IBC is introduced. The increase in pitch metrics is much smaller but the lack of a damage metric for the system does not allow quantification while the other metrics are unaffected. Estimation of time extension based on fatigue margin is given where it is shown that even small damage reductions can be beneficial. The main issue with these calculations is the lack of information on the system engineering aspect of the turbines. Knowing the design drivers and fatigue margins of the components could significantly boost such investigations and introduce optimization objectives. Moreover, the economical feasibility of such an implementation is a major consideration since the cost of upgrading or servicing the pitch system has to be evaluated in comparison with the expected income from the prolonged energy production. Further work includes comparing and combining other suitable concepts, like de-rating and lidar assisted control, with IPC for lifetime extension purposes.

Acknowledgments

This study was funded by the German Federal Ministry for Economic Affairs and Energy (BMWi) in the framework of the German joint research project ANWIND.

References

- [1] Barlas T K and van Kuik G A M 2010 Review of state of the art in smart rotor control research for wind turbines *Progress in Aerospace Sciences* **46** 1–27 ISSN 03760421

- [2] Ziegler L, Gonzalez E, Rubert T, Smolka U and Melero J J 2018 Lifetime extension of onshore wind turbines: A review covering Germany, Spain, Denmark, and the UK *Renewable and Sustainable Energy Reviews* **82** 1261–1271 ISSN 1364-0321
- [3] Det Norske Veritas Germanischer Lloyd (DNVGL) 2016 Lifetime extension of wind turbines DNVGL-ST-0262 Tech. rep. Det Norske Veritas Germanischer Lloyd (DNVGL)
- [4] Lio W H, Jones B L, Lu Q and Rossiter J 2017 Fundamental performance similarities between individual pitch control strategies for wind turbines *International Journal of Control* **90** 37–52
- [5] Bossanyi E A 2003 Wind turbine control for load reduction *Wind Energy* **6** 229–244 ISSN 10954244
- [6] van Engelen T 2006 Design model and load reduction assessment for multi-rotational mode individual pitch control (higher harmonics control) Tech. Rep. March
- [7] Selvam K, Kanev S, van Wingerden J W, van Engelen T and Verhaegen M 2009 Feedback-feedforward individual pitch control for wind turbine load reduction *International Journal of Robust and Nonlinear Control* **19** 72–91 ISSN 10498923 (Preprint arXiv:1505.02595v1)
- [8] Wang N, Wright A D and Johnson K E 2016 Independent blade pitch controller design for a three-bladed turbine using disturbance accommodating control *Proceedings of the American Control Conference* **2016-July** 2301–2306 ISSN 07431619
- [9] Barlas T K, Bergami L, Hansen M H, Pedersen M M, Thomsen K and Madsen H A Load alleviation potential of active flaps and individual pitch control in a full design load basis 2015 *EWEA Annual Conference and Exhibition 2015 Dlc* (European Wind Energy Association (EWEA))
- [10] Ungurán R and Kühn M Combined individual pitch and trailing edge flap control for structural load alleviation of wind turbines 2016 *2016 American Control Conference (ACC)* (IEEE) pp 1–9 ISBN 978-1-4673-8682-1 URL <http://ieeexplore.ieee.org/document/7524879/>
- [11] Plumley C, Leithead W, Jamieson P, Bossanyi E and Graham M 2014 Comparison of individual pitch and smart rotor control strategies for load reduction *Journal of Physics: Conference Series* **524** ISSN 17426596
- [12] Larsen T J, Madsen H A and Thomsen K 2005 Active load reduction using individual pitch, based on local blade flow measurements *Wind Energy* **8** 67–80 ISSN 10954244
- [13] Han Y and Leithead W E 2014 Combined wind turbine fatigue and ultimate load reduction by individual blade control *Journal of Physics: Conference Series* **524** ISSN 17426596
- [14] Bak C, Zahle F, Bitsche R, Yde A, Henriksen L C, Nata A and Hansen M H 2013 Description of the DTU 10 MW Reference Wind Turbine Tech. Rep. July DTU Roskilde
- [15] International Electrotechnical Commission (IEC) 2005 Wind turbines Part 1: Design requirements 61400-1 , 3rd edition Tech. rep. International Electrotechnical Commission (IEC) Switzerland
- [16] Jonkman J and Marshall B 2005 FAST User’s Guide Tech. Rep. 6 (Preprint ArXiv ID) URL <http://www.ncbi.nlm.nih.gov/pubmed/21564034>
- [17] Bir G Multi-Blade Coordinate Transformation and its Application to Wind Turbine Analysis 2008 *46th AIAA Aerospace Sciences Meeting and Exhibit* (Reston, Virginia: American Institute of Aeronautics and Astronautics) ISBN 978-1-62410-128-1 URL <http://arc.aiaa.org/doi/10.2514/6.2008-1300>
- [18] Ljung L 1999 *System identification (2nd ed.): theory for the user* (Prentice Hall PTR) ISBN 0-13-656695-2
- [19] Larimore W Canonical variate analysis in identification, filtering and adaptive control. 1990 *Proceedings of the 29th IEEE Conference on Decision and Control* (IEEE)
- [20] Miner M 1945 Cumulative Damage in Fatigue *Journal of Applied Mechanics* **3** 159–164
- [21] Lekou D, Muzakis F and Savenije F J 2005 Deliverable D4: Template for the specification of loads necessary for designing pitch systems, EU project PROTEST Tech. rep.