

**Photic and non-photic inputs
to the suprachiasmatic nucleus of the rat:
role of the serotonergic system**

Von der Fakultät Geo- und Biowissenschaften der Universität Stuttgart zur Erlangung der Würde eines Doktors der Naturwissenschaften (Dr. rer. nat) und von der Fakultät Lebenswissenschaft der Université Louis Pasteur Strasbourg zur Erlangung der Würde eines Doktors der Lebenswissenschaft genehmigte Abhandlung

**Vorgelegt von
Caroline Graff aus Strasbourg**

Hauptberichter:	Prof. Dr. Franziska Wollnik, Universität Stuttgart
Mitberichter:	Prof. Dr. Paul Pévet, Université de Strasbourg
Mitberichter:	Prof. Dr. Marie-José Freund-Mercier, Université de Strasbourg
Mitberichter:	Prof. Dr. Stephan Reuss, Universität Mainz
Mitberichter:	Dr. Olivier Bosler, Université de Marseille
Mitberichter:	Dr. Etienne Challet, Université de Strasbourg

Tag der mündlichen Prüfung: 21. November 2005

Abteilung Tierphysiologie, Biologisches Institut der Universität Stuttgart
und „Laboratoire de Neurobiologie des Rythmes, UMR 7518“ der CNRS und der Universität
Louis Pasteur von Strasbourg

2005

**Photic and non-photic inputs
to the suprachiasmatic nucleus of the rat:
role of the serotonergic system**

Von der Fakultät Geo- und Biowissenschaften der Universität Stuttgart zur Erlangung der Würde eines Doktors der Naturwissenschaften (Dr. rer. nat) und von der Fakultät Lebenswissenschaft der Université Louis Pasteur Strasbourg zur Erlangung der Würde eines Doktors der Lebenswissenschaft genehmigte Abhandlung

**Vorgelegt von
Caroline Graff aus Strasbourg**

Hauptberichter:	Prof. Dr. Franziska Wollnik, Universität Stuttgart
Mitberichter:	Prof. Dr. Paul Pévet, Université de Strasbourg
Mitberichter:	Prof. Dr. Marie-José Freund-Mercier, Université de Strasbourg
Mitberichter:	Prof. Dr. Stephan Reuss, Universität Mainz
Mitberichter:	Dr. Olivier Bosler, Université de Marseille
Mitberichter:	Dr. Etienne Challet, Université de Strasbourg

Tag der mündlichen Prüfung: 21. November 2005

Abteilung Tierphysiologie, Biologisches Institut der Universität Stuttgart

und „Laboratoire de Neurobiologie des Rythmes, UMR 7518“ der CNRS und der Universität
Louis Pasteur von Strasbourg

2005

Die vorliegende Arbeit wurde von mir selbstständig verfasst. Ich habe keine anderen als die angegebenen Quellen und Hilfsmittel benutzt. Die Koautoren der zur Veröffentlichung eingereichten Manuskripte sind jeweils genannt.

Strasbourg, den 13. Oktober 2005

Caroline Graff

Zusammenfassung

Circadiane Rhythmen werden bei allen Säugetieren durch einen endogenen Schrittmacher im Nucleus suprachiasmaticus (SCN) erzeugt und durch Umweltreize, sogenannte Zeitgeber, auf den 24 h-Rhythmus der Umwelt synchronisiert. Der wichtigste natürliche Zeitgeber ist der Licht-Dunkelwechsel, der bei allen Säugetieren über die Augen wahrgenommen wird. Nach neuesten Erkenntnissen wird die für das circadiane System relevante Lichtinformation nicht über die klassischen Photorezeptoren (Zapfen und Stäbchen) wahrgenommen, sondern über spezialisierte Ganglienzellen. Die Weiterleitung der Lichtinformation von der Retina an den SCN erfolgt über drei neuronale Afferenzen: den retinohypothalamischen Trakt (RHT), den geniculohypothalamischen Trakt (GHT) sowie über serotonerge Bahnen vom Nucleus raphe. Nach dem heutigen Wissensstand bewirken photische Stimuli während der Nacht die Freisetzung des Neurotransmitters Glutamat aus den Endigungen des RHT. Dies führt zur Aktivierung von induzierbaren Transkriptionsfaktoren, wie beispielsweise c-Fos, was wiederum die Expression diverser Uhrengene im SCN verändert und so zu einer Phasenverschiebung des circadianen Rhythmus führt. Je nach Richtung der Phasenverschiebung spricht man von Phasenbeschleunigung oder -verzögerung. Während des Tages führen nicht-photische Stimuli über die Freisetzung von Serotonin (5-HT) aus den Endigungen der serotonergen Bahn in der Regel zu Phasenbeschleunigungen, wobei sich photische und nicht-photische Stimuli auch gegenseitig beeinflussen können. Ziel der vorliegenden Arbeit war es daher, die Mechanismen der gegenseitigen Beeinflussung von photischen und nicht-photischen Stimuli genauer zu untersuchen.

Im ersten Teil der Arbeit wurde die Interaktion zwischen photischen und nicht-photischen Stimuli an Mäusen untersucht, bei denen ein 24 h Licht-Dunkelwechsel mit einer auf die Lichtphase beschränkten Fütterung einer energiearmen Diät (hypocalorie-fed mice) kombiniert wurde. Als Messgrößen für den circadianen Rhythmus wurden der Aktivitätsrhythmus, die nächtliche Melatoninausschüttung und die Expression des Neurotransmitters Vasopressin im SCN untersucht. Außerdem wurden die Expressionsmuster verschiedener Uhrengene (*Per1*, *Per2*, *Bmal1*, *Cry2*) im SCN untersucht. Im Gegensatz zu den *ad libitum* gefütterten Kontrolltieren, zeigten die Mäuse mit Futterrestriktion Phasenverschiebungen im Aktivitäts- und Melatonin-, und Vasopressin-Rhythmus sowie in der Expression verschiedener Uhrengene. Die Ergebnisse zeigen, dass restriktive Fütterung mit einer energiearmen Diät ein nicht-photischer Stimulus ist, der den synchronisierenden Einfluss des Licht-Dunkelwechsels modifizieren kann.

Läsionen der serotonergen Afferenzen zum SCN reduzierten die oben beschriebene phasenverschiebende Wirkung der restriktiven Fütterung. Dies ließ vermuten, dass die serotonerge Innervation des SCN an der Vermittlung dieses nicht-photischen Stimulus beteiligt ist. Außerdem war bereits bekannt, dass 5-HT Agonisten wie Quipazin oder DOI bei Ratten eine lichtähnliche Wirkung auf verschiedene circadiane Parameter, wie z.B. die Aktivitäts- oder Melatoninrhythmik, haben. Daraus ergab sich die Arbeitshypothese, dass 5-HT ein wichtiger Neurotransmitter bei der Verarbeitung und bei der Interaktion von photischen und nicht-photischen Eingängen in den SCN ist.

Im zweiten Teil dieser Arbeit wurden daher die neuronalen Strukturen bzw. Rezeptoren genauer charakterisiert, die an der lichtähnlichen Wirkung von 5-HT beteiligt sind. Ein früherer Befund, dass 5-HT Agonisten direkt am SCN wirken, lässt sich sowohl über präsynaptische wie postsynaptische 5-HT Rezeptoren im Bereich des SCN erklären. Um die mögliche Beteiligung präsynaptischer Rezeptoren zu testen, wurde zunächst der phasenverschiebende Effekt von Quipazin, einem unspezifischen 5-HT Agonisten, bei

Ratten mit Läsionen des RHT, des GHT oder der 5-HT Afferenzen untersucht. Dabei zeigte sich, dass weder Läsionen des GHT, noch der 5-HT Afferenzen Auswirkungen auf die Phasenverschiebung im Aktivitätsrhythmus oder die c-Fos Expression im SCN hatten. Nur nach bilateraler Läsion des RHT konnten keine Phasenverschiebungen mehr ausgelöst werden und die c-Fos Expression im SCN entsprach der von unbehandelten Kontrolltieren. Diese Ergebnisse lassen vermuten, dass Quipazin über präsynaptischen Rezeptoren auf den Nervenendigungen des RHT wirkt. Als möglicher Kandidat wurde der 5-HT₃ Rezeptor angesehen, da für diesen Rezeptortyp bereits bekannt war, dass er in anderen Bereichen des Gehirns als präsynaptischer Rezeptor auf glutamatergen Nervenendigungen die Freisetzung von Glutamat fördert.

Weitere Versuche mit 5-HT₃ spezifischen Agonisten und Antagonisten galten daher der genaueren pharmakologischen Charakterisierung. Die Ergebnisse zeigten, dass zumindest der Aktivitätsrhythmus der Tiere durch Gabe eines 5-HT₃ spezifischen Agonisten verschoben werden konnte und dass die phasenverschiebende Wirkung von Quipazin durch einen 5-HT₃ spezifischen Antagonisten blockiert werden konnte. An der gleichzeitig untersuchten Aktivierung von c-Fos im SCN scheint jedoch noch mindestens ein weiterer 5-HT Rezeptor beteiligt zu sein, da die Vorbehandlung mit einem 5-HT₃ spezifischen Antagonisten die durch Quipazin induzierte c-Fos Expression nicht komplett blockierte. Mögliche Kandidaten sind postsynaptisch lokalisierte 5-HT₇ bzw. 5-HT_{2C} Rezeptoren. So gibt es bereits eine Reihe von Veröffentlichungen, die zeigen, dass 5-HT_{2C} spezifische Agonisten und Antagonisten die phasenverschiebende Wirkung von Licht simulieren bzw. inhibieren können.

Außerdem wurde in der vorliegenden Arbeit gezeigt, dass Glutamat-Rezeptoren vom NMDA-Subtyp an der Wirkung von Quipazin auf die Aktivitätsrhythmik und auf die c-Fos Expression im SCN beteiligt sind, da die lichtähnliche Wirkung von Quipazin durch den spezifischen Antagonisten MK-801 blockiert werden konnte. Daraus ergab sich die Schlussfolgerung, dass die durch 5-HT bewirkten Phasenverschiebungen der circadianen Rhythmik durch die Aktivierung von präsynaptischen 5-HT₃ Rezeptoren auf den Terminalen des RHT und die dadurch induzierte Freisetzung von Glutamat vermittelt werden. Abschließend wurde untersucht, welchen Effekt Quipazin und ein 5-HT₃ spezifischer Agonist auf die Expression verschiedener Uhrengene haben. Hier zeigte sich lediglich eine Steigerung in der Expression von *Per1*.

Zusammenfassend zeigen die gewonnenen Ergebnisse, dass die Synchronisation der Inneren Uhr bei Säugetieren durch eine komplexe Interaktion von photischen und nicht-photischen Stimuli erfolgt. Speziell unter natürlichen Umweltbedingungen sind nicht nur der Licht-Dunkelwechsel, sondern auch andere Umweltfaktoren, wie z.B. ein eingeschränkter Zugang zu Futter, von großer Bedeutung für den Überlebenserfolg eines Tieres. Insofern ist es nur sinnvoll, dass auch nicht-photische Stimuli das circadiane System beeinflussen können und so die Anpassung an die Umwelt unterstützen. Diese nicht-photischen Stimuli werden vermutlich durch verschiedene neuronale Eingänge vermittelt, wobei die serotonergen Afferenzen zum SCN von besonderer Bedeutung sind, weil sie die Funktionalität des circadianen Systems über unterschiedliche 5-HT Rezeptoren beeinflussen können.

THESE présentée à
l'Université Louis Pasteur
Faculté des Sciences de la vie
Strasbourg, France

En cotutelle avec l'Université de Stuttgart,
Faculté de Géologie et de Biologie
Stuttgart, Allemagne

En vue de l'obtention du titre de

DOCTEUR D'UNIVERSITE

Neurosciences

Par Caroline GRAFF

**Photic and non-photic inputs
to the suprachiasmatic nucleus of the rat:
role of the serotonergic system**

***Entrées photiques et non-photiques des noyaux
suprachiasmatiques chez le rat: rôle du système
sérotonergique***

Soutenance le 21 Novembre 2005 devant la commission d'examen:

Dr. Olivier Bosler - Rapporteur externe

Prof. Dr. Stephan Reuss - Rapporteur externe

Prof. Dr. Marie-José Freund-Mercier - Rapporteur interne

Dr. Paul Pévet - Directeur de thèse

Prof. Dr. Franziska Wollnik - Co-Directeur de thèse

Dr. Etienne Challet - Examineur

Abstract

In mammals, circadian rhythms are controlled by a master clock localized in the suprachiasmatic nucleus (SCN) and entrained to 24 h by external cues. These signals are conveyed by three main afferences: the retinohypothalamic tract (RHT), the geniculohypothalamic tract (GHT) and the serotonergic tract. Photic factors during the night, leading to glutamate release from the RHT and *c-Fos* and clock gene expression in the SCN, induce phase shifts of the locomotor activity rhythm. Non-photonic factors during the day generally induce phase advances of the locomotor activity rhythm and involve serotonin (5-HT) release from the serotonergic tract. Photic and non-photonic factors can interact and modulate their respective effects. The purpose of my thesis is to better understand the mechanisms underlying these interactions.

In the first part of this work, we have investigated the interaction between a photic factor and a non-photonic factor on different circadian parameters in mice exposed to a light-dark cycle and fed daily with a diurnal hypocaloric diet (hypocaloric-fed mice). Compared to control animals fed *ad libitum*, the hypocaloric-fed mice showed phase changes of the locomotor activity, the melatonin secretion and the vasopressin expression rhythms and showed significant phase advances of two clock gene expression. There were also changes of light-induced phase shifts of the locomotor activity rhythm and light-induced clock gene expression in hypocaloric-fed mice. Thus, diurnal hypocaloric feeding is a non-photonic factor able to modulate the synchronizing effects of light in the mouse.

Lesion of serotonergic afferences to the SCN induces a marked reduction of the phase shifting effects of the diurnal hypocaloric feeding, implicating 5-HT in the neuronal mechanisms underlying these effects. In rats, 5-HT agonists are known to mimic the effect of light on various parameters of the SCN. We thus proposed that 5-HT could play a role in the functional interaction between photic and non-photonic factors in the SCN and we thus studied the neuronal mechanisms mediating the photic-like shifting effects of 5-HT in the rat.

In the second part of this work, we first tried to localize the 5-HT receptors implicated in these photic-like effects. As serotonergic agonists act directly in the SCN, these receptors can be either presynaptic or postsynaptic. To test the presynaptic hypothesis, we studied the phase shifting effects of a non-specific serotonergic agonist, the quipazine, in animals bearing lesions of either the serotonergic afferences, the GHT or the RHT. Our results implicate the RHT suggesting that the 5-HT receptors involved are localized on terminals of this tract. The possible serotonergic receptor subtype involved in these photic-like effects of 5-HT could be the 5-HT₃ receptors since they have been shown in other brain structure to be localized on glutamatergic terminals and to induce glutamate release. Our results obtained with a specific 5-HT₃ agonist and a specific 5-HT₃ antagonist on several circadian parameters demonstrate the implication of the 5-HT₃ receptor in the photic-like resetting effects of quipazine on the locomotor activity rhythm. However, another 5-HT receptor subtype seems to be involved in the induction of *c-FOS* expression by quipazine. In addition, we found that NMDA receptors, which are activated by glutamate release, participate in the phase advance of the locomotor activity rhythm and in the *c-FOS* expression in the SCN, induced by quipazine injection. Thus, the resetting effects of 5-HT in rats are mediated by presynaptic 5-HT₃ receptors localized on the RHT terminals that trigger glutamate release, thus producing photic-like behavioral shifts.

Résumé

Chez les mammifères, les rythmes circadiens sont contrôlés par une horloge biologique, localisée dans les noyaux suprachiasmatiques (SCN), qui est entraînée à 24 h par des facteurs externes. Ces informations sont véhiculées par trois afférences majeures : le tractus rétinohypothalamique (RHT), le tractus géniculohypothalamique (GHT) et le tractus sérotonergique. Les facteurs photiques de nuit provoquent des décalages de phase du rythme d'activité locomotrice impliquant la libération de glutamate par le RHT et l'expression de *c-fos* et des gènes horloges dans les SCN. Les facteurs non-photiques de jour induisent des avances de phase du rythme d'activité locomotrice en relation avec la libération de la sérotonine (5-HT) du tractus sérotonergique. Les facteurs photiques et non-photiques peuvent interagir et moduler leurs effets respectifs. Ces mécanismes d'interaction encore mal connus, sont l'objet de mon projet de thèse.

Dans la première partie de ce travail, nous avons étudié l'interaction entre un facteur photique et un facteur non-photique sur différents paramètres circadiens chez des souris placées en cycle lumière/obscurité et soumises quotidiennement à un nourrissage hypocalorique diurne (souris hypocaloriques). Nous avons montré chez ces souris que le rythme d'activité locomotrice, de sécrétion de mélatonine et d'expression de la vasopressine est significativement modifié par rapport aux témoins. De plus, une avance de phase significative de l'expression de deux gènes horloges a été mise en évidence. Nous avons obtenu des variations majeures des décalages de phase et de l'expression de gènes horloges dans les SCN, induits par la lumière chez les souris hypocaloriques. Le nourrissage hypocalorique diurne est donc un facteur non-photique capable de moduler l'effet d'entraînement de la lumière chez la souris.

La lésion des afférences sérotonergiques des SCN entraîne une nette réduction des effets synchroniseurs du nourrissage hypocalorique diurne, suggérant l'implication de la 5-HT dans les mécanismes neuronaux sous-jacents. Chez le rat, les agonistes de la 5-HT miment les effets de la lumière sur différents paramètres de l'horloge. L'hypothèse selon laquelle la 5-HT pourrait jouer un rôle dans l'interaction fonctionnelle entre les facteurs photiques et non-photiques au sein des SCN mérite d'être testée en étudiant les effets de type photiques de la 5-HT chez le rat.

Dans la deuxième partie du travail, nous avons tenté de localiser les récepteurs sérotonergiques impliqués dans les effets de type photique de la 5-HT. Sachant que les agonistes sérotonergiques agissent au niveau des SCN, les récepteurs sérotonergiques mis en jeu peuvent être présynaptiques ou postsynaptiques. Pour tester l'hypothèse présynaptique, nous avons étudié l'effet synchroniseur d'un agoniste sérotonergique non-spécifique, la quipazine, chez des animaux ayant une lésion des afférences sérotonergiques, du GHT ou du RHT. Nos résultats suggèrent une localisation sur les terminaisons du RHT des récepteurs 5-HT impliqués dans ces effets. Pour identifier le sous-type de récepteurs sérotonergiques, l'utilisation d'un agoniste et un antagoniste spécifiques du récepteur 5-HT₃ nous a permis de mettre en évidence le rôle de ce récepteur dans les effets de type photique de la 5-HT sur le rythme d'activité locomotrice. Toutefois, un autre sous-type de récepteur 5-HT participe à l'induction de l'expression de *c-FOS* dans les SCN par la quipazine. De plus, nos résultats montrent l'implication des récepteurs NMDA qui sont activés par la libération de glutamate dans les effets d'avance de phase du rythme d'activité locomotrice et de l'expression de *c-FOS* dans les SCN, induits par la quipazine. Ainsi, les effets synchroniseurs de la 5-HT chez le rat font intervenir les récepteurs 5-HT₃ présynaptiques localisés sur les terminaisons du RHT, qui entraînent la libération de glutamate et par conséquent qui induisent des décalages de phase comportementaux de type photique.

Acknowledgements – Remerciements - Danksagung

I would like to thank all the persons which contribute and give me support to realize this PhD thesis.

I would like specially to thank all the people from the “Laboratoire de Neurobiologie des Rythmes” in Strasbourg and from the “Biologisches Institut, Abteilung Tierphysiologie” in Stuttgart.

Je tiens à remercier le **Dr. Paul Pévet** pour m’avoir accueilli dans son laboratoire lors de mon DEA et pour m’avoir soutenu et guidé tout au long de ma thèse. Je vous remercie sincèrement d’avoir cru en moi et de m’avoir permis de réaliser cette thèse en co-tutelle, qui fut tellement enrichissante. En Allemagne on parle de *Doktorvater*, traduit littéralement par « Père du Doctorat ». C’est tout à fait ce que vous avez été pour moi...

De même, je tiens à remercier chaleureusement le **Dr. Etienne Challet** pour mon année de DEA, pour son soutien et ses conseils éclairés, même après mon départ pour Stuttgart. Merci pour ta disponibilité et ta gentillesse, merci pour tes corrections. J’ai été très heureuse et fière d’être ta première étudiante !!

Merci à **Sylviane Gourmelen** pour son aide précieuse et son efficacité. Merci sincèrement à **Françoise Eclancher** pour son aide lors de la rédaction de mes articles et de ma thèse.

Merci beaucoup à **Christine Erhardt** pour sa contribution lors de mes expériences.

Je voudrais ensuite remercier tous mes “potos du labo” : **VJ, Hugues, Jérôme, Marie-Laure, Cathy** (« Bonne chance pour la fin de ta thèse »), **Florent** (« Un grand merci pour m’avoir initié au clonage ! »), **Ben, Zeina, Anthony, Corina, Annika** (« Merci pour ton aide précieuse en allemand »), **Marc** et tout mes colocataires du fameux “bureau étudiant” : **Laurent** (« Courage tu arrive au bout ! »), **Laurence, Céline**, et toutes les personnes que j’oublie, pour les discussions passionnées et surtout votre bonne humeur !!! Merci beaucoup à **Stéphanie** pour les moments partagés en congrès (« C’était très sympas ! »).

Merci à mes amis du 2^{ème} et du 3^{ème} étage: **Matthias, les deux Céline, Isa**, pour les repas de midi, les soirées improvisées et les pause-café.

Außerdem danke ich **Prof. Dr. Franziska Wollnik** für die herzliche Aufnahme in Ihrem Labor. Vielen Dank Franziska für Deine wertvolle Hilfe als ich nach Stuttgart gekommen bin: Wohnungssuche, Administration (besonders Steuererklärung), Versuche, soziale Kontakte wäre ohne Dich schwer gewesen. Schade, daß Du an meinem Thema nicht mehr weiterarbeitest. Danke für die schöne Zeit in Stuttgart.

Herzlichen Dank an **Holger Fuchs**, dem ersten Mitbewohner meines Arbeitszimmers und auch seiner Familie die mich mit offenen Armen aufgenommen hat.

Ein besonderes Dankeschön an **Angeline Votteler** die mir alles im Labor gezeigt hat und auch mit mir tanzen gegangen ist!!! Es war super mit Dir zu arbeiten, ich konnte mich immer auf Dich verlassen.

Danke **Harald** daß Du Dich um die Zucht von meinen Tieren gekümmert hast.

Uwe, Olly und **Nicole** danke ich für das gute Arbeitsklima. Ich wünsche Euch Viel Erfolg für die Zukunft.

Hagen, Vielen Dank für Deine Unterstützung, besonders Abends mit Filmen. Dir und **Birgit** danke ich außerdem dafür, daß Ihr immer einen Platz zum Schlafen für mich hattet. Es war immer schön mit Euch im Scherlok essen zu gehen.

Die Zeit in Stuttgart war sehr wertvoll für mich, ich habe viel gelernt (nicht nur wissenschaftlich!!!!).

Mais surtout, je remercie ma famille, et plus particulièrement mes parents qui m'ont soutenu pendant toutes ces années.

Et merci sincèrement à toi, mon Franck,....

Table of Content

Table of Content

Abbreviations	25
----------------------	-----------

INTRODUCTION	29
---------------------	-----------

I. Circadian rhythms	31
-----------------------------	-----------

<i>I.1. Definition and properties</i>	31
---------------------------------------	----

I.2. An example of circadian rhythms:

<i>the locomotor activity rhythm</i>	32
--------------------------------------	----

II. The suprachiasmatic nucleus	33
--	-----------

<i>II.1. The suprachiasmatic nucleus is the location of the master clock: experimental proofs</i>	34
---	----

II.1.1. Lesion and transplantation experiments	34
--	----

II.1.2. Intrinsic circadian rhythms: electrophysiology and metabolism	35
--	----

<i>II.2. Cellular organization of the SCN</i>	36
---	----

II.2.1. Localization and anatomy	36
----------------------------------	----

II.2.2. Content in neuropeptides et neurotransmitters	37
---	----

II.2.2.1. GABA	38
----------------	----

II.2.2.2. Vasopressin	38
-----------------------	----

II.2.2.3. Vasoactive Intestinal Peptide	39
---	----

II.2.2.4. Gastrin-Releasing Peptide	40
-------------------------------------	----

II.2.2.5. Somatostatin	40
------------------------	----

II.2.2.6. Calbindin-D _{28K}	40
--------------------------------------	----

<i>II.3. Rhythm genesis in the SCN</i>	41
--	----

II.3.1. Molecular basis of the circadian rhythmicity	41
--	----

II.3.1.1. The positive loop	43
-----------------------------	----

II.3.1.2. The negative loop.....	45
II.3.1.3. The Rev-erb α loop.....	49
II.3.1.4. Post-translational mechanisms.....	49
II.3.2. Cellular basis of the circadian rhythmicity: Mechanisms of cellular synchronization.....	50
III. Entrainment of circadian rhythms.....	53
<i>III.1. The daily entrainment of the SCN.....</i>	<i>55</i>
III.1.1. Afferences of the SCN.....	55
III.1.1.1. The retinohypothalamic tract (RHT): the main photic afference.....	55
III.1.1.2. The geniculohypothalamic tract (GHT).....	57
III.1.1.3. The serotonergic tract.....	58
III.1.1.4. Other afferences of the SCN.....	59
III.1.2. Mechanisms of entrainment.....	59
III.1.2.1. Photic entrainment of the SCN.....	59
<i>Physiological level.....</i>	59
<i>Cellular level.....</i>	61
<i>Molecular level.....</i>	64
III.1.2.2. Non-photoc entrainment of the SCN.....	66
<i>Physiological level.....</i>	66
<u>Behavioral cues.....</u>	66
<u>Metabolic cues.....</u>	67
<u>Other cues.....</u>	68
<i>Cellular level.....</i>	68
<i>Molecular level.....</i>	69
III.1.2.3. Interactions between photic and non-photoc cues.....	70
<i>Physiological level.....</i>	70
<i>Cellular level.....</i>	71
<i>Molecular level.....</i>	71
<i>III.2. The distribution of the circadian message.....</i>	<i>72</i>
III.2.1. Neuronal pathways.....	73

III.2.2. Distribution of the rhythmic message by a diffusible signal.....	75
III.2.2.1. Experimental evidences	75
III.2.2.2. Candidates for diffusible signals	76
III.2.3. Rhythmicity outside the SCN.....	76
IV. The serotonergic system	79
<i>IV.1. The serotonergic system in the central nervous system</i>	79
IV.1.1. Anatomical data.....	79
IV.1.1.1. Serotonergic nuclei	79
IV.1.1.2. Afferences	79
IV.1.1.3. Efferences	82
<i>Descending projections</i>	82
<i>Ascending projections</i>	82
IV.1.2. Serotonergic neuron functioning.....	83
IV.1.2.1. Serotonin metabolism	83
<i>Synthesis</i>	83
<i>Degradation</i>	84
IV.1.2.2. Storage and release of 5-HT	85
IV.1.2.3. Electrical activity of 5-HT neurons	85
IV.1.3. Serotonergic receptors.....	87
IV.1.3.1. The 5-HT₁ receptor class	87
<i>5-HT_{1A} receptors</i>	87
<i>5-HT_{1B} receptors</i>	88
<i>5-HT_{1D} receptors</i>	88
<i>5-HT_{1E} receptors</i>	90
<i>5-HT_{1F} receptors</i>	90
IV.1.3.2. The 5-HT₂ receptor class	90
<i>5-HT_{2A} receptors</i>	90
<i>5-HT_{2B} receptors</i>	90
<i>5-HT_{2C} receptors</i>	91
IV.1.3.3. The 5-HT₃ receptor class: an intrinsic ligand-gated channel ..	91
IV.1.3.4. The 5-HT_{4,6,7} receptors	92

5-HT ₄ receptors.....	92
5-HT ₆ receptors.....	92
5-HT ₇ receptors.....	92
IV.1.3.5. The 5-HT₅ receptors.....	93
IV.2. The serotonergic system:	
<i>relationship with the circadian system.....</i>	93
IV.2.1. Circadian control of serotonergic system.....	93
IV.2.1.1. Tryptophan availability and uptake.....	93
IV.2.1.2. TpH and 5-HTP decarboxylase quantity and activity.....	94
IV.2.1.3. Serotonin content and release.....	95
IV.2.2. Role of serotonin in circadian rhythms.....	95
IV.2.2.1. Role of serotonin in the Syrian hamster.....	96
IV.2.2.2. Role of serotonin in the mouse.....	97
IV.2.2.3. Role of serotonin in the rat.....	98

SCOPE OF THE THESIS 101

RESULTS 105

I. First part.....	107
Interaction between a photic cue, i.e. the light-dark cycle and a non-photoc cue, i.e. the timed caloric restriction.	
<i>Introduction.....</i>	107
<i>Article 1.....</i>	109
<i>Feeding cues alter clock gene oscillations and photic responses in the suprachiasmatic nuclei of mice exposed to a light-dark cycle</i>	
Abstract.....	110
Introduction	110
Material and Methods.....	112
Animal housing and experimental design.....	112
Behavioral phase shifts.....	112
Circadian oscillations of clock genes.....	113

Light-induced behavioral phase shifts	114
Responses to light of pineal melatonin and clock genes	115
Statistical analysis	115
Results.....	117
Changes in daily pattern of wheel-running activity	117
Changes in day-night pattern of food intake, body mass and 24 h blood glucose	120
Changes in expression of clock and clock-controlled genes	122
Changes in circadian rhythm and light-induced suppression of pineal melatonin	127
Altered phase shift responses of locomotor activity rhythm to light	129
Altered responses of clock gene expression to light	130
Discussion.....	132
No phase shifting effect of normocaloric feeding	132
Phase shifting effects of hypocaloric feeding	133
Effects of hypocaloric feeding on SCN gene expression	134
Behavioral circadian responses to light	135
Molecular circadian responses to light	136
Acknowledgements.....	136

II. Second part.....139

Localisation and subtype of the 5-HT receptor(s) involved in the photic-like effects of 5-HT agonists in the rat

<i>Introduction</i>	139
---------------------------	-----

<i>Article 2</i>	141
------------------------	-----

Involvement of the retinohypothalamic tract in the photic-like effects of the 5-HT agonist quipazine in the rat

Abstract.....	142
Introduction.....	142
Materials and Methods.....	144

Animals	144
Surgical procedures	145
<i>Bilateral IGL lesions</i>	145
<i>5-HT depletion</i>	145
<i>Biocular enucleation</i>	146
Experimental protocol	146
Histological procedures, control of the lesions and immunohistochemical procedures	147
Behavior analyses	148
Statistics	148
Results	149
Histology	149
<i>IGL lesions</i>	149
<i>5-HT depletion</i>	150
<i>Biocular enucleation</i>	151
Circadian activity parameters	152
<i>IGL lesions</i>	152
<i>5-HT depletion</i>	155
<i>Biocular enucleation</i>	157
Effect of quipazine on c-FOS expression	159
Discussion	160
Photic-like effects of quipazine	160
Presynaptic hypothesis	162
Post-synaptic hypothesis	163
Acknowledgments	164
<i>Appendum</i>	165
<i>Article 3</i>	167
<i>5-HT₃ receptor-mediated photic-like responses</i> <i>of the circadian clock in the rat</i>	
Abstract	168
Introduction	168
Methods	171

Animals	171
Experimental protocol	171
<i>First set of experiments: Effect of serotonergic and glutamatergic drugs on the locomotor activity rhythm</i>	171
<i>Second set of experiments: Effect of serotonergic and glutamatergic drugs on the expression of c-FOS in the SCN</i> ...	172
<i>Experiment 7: Effect of serotonergic drugs on the expression of clock genes in the SCN</i>	173
Behavior analyses	173
Histological procedures	173
<i>c-FOS immunocytochemistry procedure</i>	173
<i>In situ hybridization of clock genes</i>	174
Statistics	175
Results	177
First set of experiments: Effect of serotonergic and glutamatergic drugs on the locomotor activity rhythm	177
Second set of experiments: Effect of serotonergic and glutamatergic drugs on the expression of c-Fos in the SCN	180
Experiment 7: Effect of serotonergic drugs on the expression of clock genes in the SCN	184
Discussion	186
Photic-like effects of quipazine	186
Involvement of the 5-HT₃ receptor in 5-HT photic-like effect on locomotor activity rhythm	187
Involvement of the 5-HT₃ receptor in 5-HT photic-like effect on c-FOS and clock genes expression in the SCN	188
Acknowledgments	190

GENERAL DISCUSSION AND PERSPECTIVES **191**

**I. Interaction between a non-photoc cue,
the timed caloric restriction and a photic cue,
the LD cycle**.....193

I.1. SCN integration.....193

I.2. Light entrainment modulation.....195

I.3. A possible role of 5-HT system.....196

**II. Neuronal mechanisms of photic-like resetting effects
of 5-HT agonists in rats**.....198

II.1. Localization of the 5-HT receptor(s) involved.....198

II.2. Subtype of the 5-HT receptor involved.....199

*II.3. A possible model for the photic-like resetting
effects of 5-HT*.....202

III. Conclusion and perspectives.....205

References **207**

PUBLICATIONS AND SCIENTIFIC POSTERS **231**

Abbreviations

- 3V:** Third ventricle
5,7-DHT: 5,7-dihydroxytryptamine
5-CT: 5-carboxamidotryptamine
5-HIAA: 5-hydroxyindole acetic acid
5-HT: Serotonin or 5-hydroxytryptamine
5-HTP: 5-hydroxytryptophan
5-HT-X_p: partially 5-HT lesioned
5-HT-X_w: wholly 5-HT-lesioned
8-OH-DPAT: 8-hydroxy-di-*n*-propylamino tetralin
αMe-5-HT: Alpha-methylserotonin
τ: Tau
ANOVA: Analysis of variance
AP-1: Activator protein-1
Arnt: Aryl hydrocarbon receptor nuclear translocator
a.u.: Arbitrary unit
bHLH: Basic helix-loop-helix
BIMU-8: 1'-[4-[1-(4-fluorophenyl)-1H-indol-3-yl]-1-butyl]spiro[iso-benzofuran-1(3H), 4'piperidine] (Lu28-179), endo-N-(8-methyl-8-azabicyclo[3.2.1]oct-3-yl)-2,3-dihydro-(1-methyl)ethyl-2-oxo-1H-benzimidazole-1-carboxamidehydrochloride
BMAL1: Brain and muscle arnt like protein 1
BNST: Bed nucleus of the stria terminalis
BRL 15572: 1-(3-chlorophenyl)-4-[3,3-diphenyl(2-(S,R) hydroxypropanyl) piperazine]
BW723C86: (±)1-[5-(2-thenyloxy)-1H-indol-3-yl] propan-2-amine hydrochloride
Ca²⁺: Calcium
CalB: Calbindin-D_{28K}
cAMP: Cyclic adenosine monophosphate
ccg: Clock-controlled gene
cGMP: Cyclic guanosine monophosphate
CKIε: Casein kinase I ε
CLD: Cytoplasmic localization domain
CLOCK: Circadian locomotor output cycles kaput
CRE: CREB-responsive element
CREB: cAMP response element binding protein
CRY: Cryptochrome
CT: Circadian time
DD: Constant darkness
DEC: Differentially expressed in chondrocytes protein
DLG: Dorsal lateral geniculate
DMH: Dorsomedial nucleus of the hypothalamus
dmSCN or DM: Dorsomedial region of the SCN
DOB: 1-(4-bromo-2, 5-dimethoxyphenyl)-2-aminopropane
DOI : (±)-1-(2,5-dimethoxy-4-iodophenyl)-2-aminopropane HCL
DR4004: 2a-[4-(4-phenyl-1,2,3,6-tetrahydropyridyl)butyl]-2a,3,4,5-tetrahydro-benzo[cd]indol-2(1H)-one
DRN: Dorsal raphe nucleus
EGFR: Epidermal growth factor receptor
ENK: Enkephaline
EPSCs: Excitatory postsynaptic currents
ERK: Extracellular signal-regulated protein kinases
FAA: Food anticipatory activity
G: Protein G
GABA: γ-Aminobutyric acid
GAD: Glutamic acid decarboxylase
GC: Guanylate cyclase
GHT: Geniculohypothalamic tract
GLU: Glutamate
GR 113808: [1-(2-methylsulphonylamino)ethyl]-4-piperidinylmethyl] 1-methyl-1*H*-indole-3-carboxylate
GR 55562: [3-(N,N-dimethylamino)propyl]-4-hydroxy-N-[4-(pyridin-4-yl)phenyl]benzamide
GRP: Gastrin releasing peptide
GTPases: Guanosine triphosphatases
IEG: Immediate early gene
IGL: Intergeniculate leaflet
IGL-X_p: Partially IGL-lesioned
IGL-X_w: Wholly IGL-lesioned
i.m.: Intramuscular
i.p.: Intraperitoneal
ir: Immunoreactivity
KO: Knock-out

L 694247: 247 (2-[5-[3-(4-methylsulphonylamino)benzyl-1,2,4-oxadiazol-5-yl]-1H-indole-3-yl]ethylamine)
LD: Light-dark
LL: Constant light
LP: Light pulse
LS: Lateral septum
LY334370: 5-(4-fluorobenzoyl)amino-3-(1-methylpiperidin-4-yl)-1H-indole fumarate
MAO: Monoamine oxydase
MAP kinase: Mitogen-activated protein kinase
m-CPBG: m-chlorophenylbiguanide
mCPP: 1-(3-chlorophenyl)-piperazine HCl
MDL 100907: R-(1)- α (2,3-dimethoxyphenyl)-1-[2(4-fluorophenethyl)]-4-piperidinemethanol
MDL 72832: 8-[4-(1,4-benzodioxan-2-ylmethylamino)butyl]-8-azaspiro++ +[4,5]decane-7,9-dione
MK-212: 6-chloro-2-[1-piperazinyl]-pyrazine
MK-801: (+)-5-methyl-10,11-dihydroxy-5H-dibenzo(a,d)cyclohepten-5,10-imin
ML 10302: 2-piperidinoethyl 4-amino-5-chloro-2-methoxybenzoate
MPN: Medial preoptic nucleus
MPO: Medial preoptic area
MRN: Median raphe nucleus
NAN-190: 1-(2-methoxyphenyl)-4(4-(2-phthalimido)butyl)piperazine
NCAM: Neural cell adhesion molecule
n.d.: Not determined
NLS: Nuclear localization signal
NMDA: N-methyl-D-aspartate
NO: Nitric oxide
NOS: NO synthase
NPY: Neuropeptide Y
OC: Optic chiasma
ODN: Antisense phosphotioate oligonucleotide
PACAP: Pituitary adenylate cyclase-activating peptide
PAS: Period-arnt-sim
PBS: phosphate-buffered saline
PBST: PBS containing 0.1% Triton X-100
PER: Period
PHI: Peptid histidine isoleucine
PK2: Prokineticine 2
PK2R: PK2 receptor
PKA: Protein kinase A
PLC: Phospholipase C
PNU-109291: (S)-(-)-1-[2-[4-(4-methoxyphenyl)-1-piperazinyl]ethyl]-N-methyl-isochroman-6-carboxamide
PRC: Phase response curve
PSA: Polysialic acid
PVN: Paraventricular nucleus of the hypothalamus
PVT: Paraventricular nucleus of the thalamus
PZT: Projected Zeitgeber time
REM: Rapid-eye-movement
RHT: Retinohypothalamic tract
Ro 25-1553: Ac-(Glu⁸, Lys¹², Nle¹⁷, Ala¹⁹, Asp²⁵, Leu²⁶, Lys^{27,28}, Gly^{29,30}, Thr³¹)-VIP cyclo (21-25)
Ro 60 0175: (S)-2-chloro-5-fluoro-indol-1-yl)-1-methyl ethylamine fumarate
ROR α : Retinoid-related orphan receptor α
RORE: Retinoid-related orphan response element
RS-102221: 8-[5-(5-amino-2,4-dimethoxyphenyl) 5-oxopentyl]-1,3,8-triazaspiro[4.5]decane-2,4-dione
RS 23597-190: 3-(piperidine-1-yl) propyl-4-amino-5-chloro-2-methoxy-benzoate hydrochloride
RS 67506: 4-amino-5-chloro-2-methoxyphenyl)-3-[1-2-methylsulphonylamino-ethyl-4-piperidinyl]-1-propanone
SB 200646: N-(1-methyl-5-indolyl)-N'-(3-pyridyl) urea hydrochloride
SB-204070: 8-amino-7-chloro-(N-butyl-4-piperidyl)methylbenzo-1,4-dioxan-5-carboxylate hydrochloride
SB-204741: N-(1-methyl-5-indolyl)-N'-(3-methylisothiazol-5-yl)urea
SB 224289: 1'-methyl-5-([2'-methyl-4'-(5-methyl-1,2,4-oxadiazol-3-yl)biphenyl)-4-yl]carbonyl)-2,3, 6,7-tetrahydrospiro[furo [2,3-f]indole-3,4'-piperidine]
SB 236057: 1'-ethyl-5-(2'-methyl-4'-(5-methyl-1,3,4-oxadiazol-2-yl)biphenyl-4-carbonyl)-2,3,6,7-tetrahydrospiro[furo[2,3-f] indole-3,4'-piperidine]

SB 242084 : 6-chloro-5-methyl-1-[6-(2-methylpyridin-3-yloxy) pyridin-3-yl carbonyl] indoline
SB-258719: (R)-3,N-Dimethyl-N-[1-methyl-3-(4-methylpiperidin-1-yl)propyl]benzene sulfonamide
SB-269970: (R)-3-(2-(2-(4-methylpiperidin-1-yl)ethyl)-pyrrolidine-1-sulphonyl)-phenol)
SB-271046: 5-chloro-N-(4-methoxy-3-piperazin-1-yl-phenyl)-3-methyl-2-benzothiophenesulfonamide
SB-357134: N-(2,5-Dibromo-3-fluorophenyl)-4-methoxy-3-piperazin-1-ylbenzenesulfonamide
SBP: Serotonin binding protein
s.c.: Subcutaneous
SCN: Suprachiasmatic nucleus
S.E.M: Standard error of the mean
SOM: Somatostatin
SP: Substance P
sPVz: Subparaventricular zone
SR 57227 : 4-amino-(6-chloro-2-pyridyl)-1-piperidine
TFMPP: 1-(3-trifluoromethylphenyl) piperazine
TGF α : Transforming growth factor alpha
TpOH: Tryptophan hydroxylase
TRY: Tryptophan
TTX: Tetrodotoxin
V1aR: Vasopressin V1a receptor
VIP: Vasoactive intestinal polypeptide
Vip $^{-/-}$: KO mutant for the VIP gene
Vipr2 $^{-/-}$: KO mutant for the VPAC₂ gene
VLG: Ventral lateral geniculate
vLSCN or VL: Ventrolateral region of the SCN
VMH: Ventromedial nucleus of the hypothalamus
VPAC: VIP/PACAP receptor
VP: Vasopressin
WAY 100635: N-[2[4-(2-methoxyphenyl)-1-piperazinyl]ethyl]N-(2-pyridinyl)cyclohexanecarboxamide trihydrochloride
ZT: Zeitgeber time

Introduction

INTRODUCTION

Survival of animals depends on their adaptation to their environment. One of the most important adaptive process is the capacity to anticipate events. Thus, animals have to develop behavioral and physiological responses to predictable changes in environmental parameters. The daily light-dark (LD) cycle lasting 24 h, due to earth rotation, is the most reliable of them. The organism is able to anticipate daily events such as mealtime. But light gives another information: season. Except at the level of Equator, duration of the light phase depends on time of year. Seasonal adaptations allow pups to be born at the most favorable period of the year occurring during springtime.

An internal timing system is therefore required to elaborate adapted responses to those time cues. Moreover, this system, defined as the circadian system, is able to generate circadian rhythms and thus to give an endogenous rhythmic message to the whole body, without external information.

In this introduction, I will first define what a circadian rhythm is. I will then focus on the suprachiasmatic nucleus (SCN), the site of the main circadian clock. I will further detail the mechanisms of rhythms entrainment to finally describe a very important afferent system of the SCN: the serotonergic system, which is together with the mechanisms of entrainment, the main focus of the present work.

I. Circadian rhythms

1.1. Definition and properties

According to the period length, it is possible to characterize different rhythms: ultradian (period smaller than 20 h), **circadian** (period close to 24 h) and infradian (period longer than 28 h). My work will focus on the circadian rhythms.

A circadian rhythm is **endogenous**, meaning that it persists in the absence of external time cues. There is therefore a major difference between circadian and daily rhythms. Both occur on a daily basis, but contrary to a circadian rhythm, a daily rhythm disappears without external time cues. Temperature compensation, preventing temperature variations to have an

effect on the speed of clocks, is the second main feature of a circadian rhythm. Finally, circadian rhythms can be **synchronized** to exactly 24 h through the resetting effects of environmental cues, named **Zeitgebers**, such as alternation of light and dark periods, so-called **light-dark (LD) cycles**.

1.2. An example of circadian rhythms: the locomotor activity rhythm

In rodents, the first circadian rhythm observed was the locomotor activity rhythm measured in a running-wheel. Indeed, this locomotor activity rhythm shows an alternation of a **rest** and an **active phase**. Without Zeitgeber (meaning in constant conditions, e.g. in **constant darkness (DD)**), animals are **free-running** (Fig. 1). The period of the locomotor activity rhythm, named *tau* (τ) is therefore close to, but not equal to 24 h, and results in daily shiftings of this rhythm compared to the astronomic time. The duration of the circadian day is equal to τ and divided into two phases: **subjective day** and **subjective night**, corresponding to rest and active phase, respectively, for nocturnal animals. The circadian day is also divided into 24 circadian hours or **circadian time (CT)**, CT 0 (=CT 24) being the beginning of the subjective day and CT 12 the beginning of the subjective night.

In natural conditions, animals are entrained to the 24 h period LD cycles, using mechanisms of entrainment explained in the chapter: "III. Entrainment of circadian rhythms".

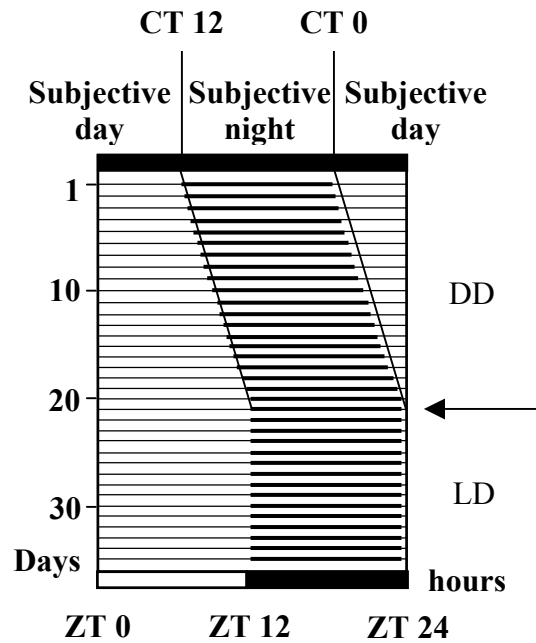

Figure 1. Locomotor activity rhythm of a hamster in constant darkness (DD). The animal is free running and its endogenous period is larger than 24 h. In light-dark (LD) cycle (down from the arrow) the rhythm is entrained. CT: Circadian time, ZT: Zeitgeber time.

II. The suprachiasmatic nucleus

The circadian rhythms are generated and distributed to the rest of the body by a master clock (Klein *et al.*, 1991). In mammals, this master clock is located in the suprachiasmatic nucleus (SCN) of the hypothalamus. Nevertheless, other brain structures or organs of the body can build rhythms. Two terms can therefore be distinguished and applied to structures that generate rhythms. First, **oscillators** (or pacemakers) are defined as structures that generate rhythms, that can be transient or self-sustained (that persist without external information). Second, a **clock** is an oscillator that is entrained by external stimuli and is able to distribute rhythmic messages to other structures. However, up to now, no definitive nomenclature has been determined.

II.1. The suprachiasmatic nucleus is the location of the master clock: experimental proofs

In order to be considered as the master clock, the SCN has to fulfill different criteria:

- * The SCN has to generate intrinsic (i.e., endogenous) rhythms.
- * The SCN must receive photic inputs in order to be reset by light.
- * The SCN must have the capacity to distribute the rhythmic information to the whole body.
- * The lesion of the SCN must abolish physiological rhythms.

The second and the third conditions will be detailed in the third chapter: "III. Entrainment of circadian rhythms".

II.1.1. Lesion and transplantation experiments

The discovery of the circadian clock location has been realized in 1972, when two independent teams showed that the lesion of a structure of the hypothalamus, the SCN, induced a loss of corticosterone secretion rhythm (Moore and Eichler, 1972), of drinking and locomotor activity rhythms (Stephan and Zucker, 1972) (Fig. 2). Moreover, transplantation of fetal or early postnatal SCN tissue was able to restore circadian rhythmicity in some behavioral parameters like locomotor activity (Ralph *et al.*, 1990) but not melatonin secretion (Meyer-Bernstein *et al.*, 1999). In addition, the period of the rhythms restored was determined by the donor (Ralph *et al.*, 1990). Two different transplantation experiments have demonstrated that circadian period is an intrinsic property of the SCN.

The first example is the transplantation study using the **tau mutant hamster**, in which heterozygotes has a circadian period length of about 22 h and the homozygotes has a period of about 20 h (Ralph and Menaker, 1988). Donor SCN obtained from a homozygous tau mutant hamster restored a 20 h rhythm in an arrhythmic SCN-lesioned host animal with a 24 h rhythm prior to lesion and vice versa.

The second example is the transplantation study using the **vasopressin-deficient homozygous Brattleboro rats**, which have a longer endogenous period (Boer *et al.*, 1999). In the same way, SCN transplants derived from homozygous and heterozygous Brattleboro fetuses restored a circadian rhythm with a similar difference in period length (24,3 vs. 23,8 h) as reported for the intact adult Brattleboro genotypes.

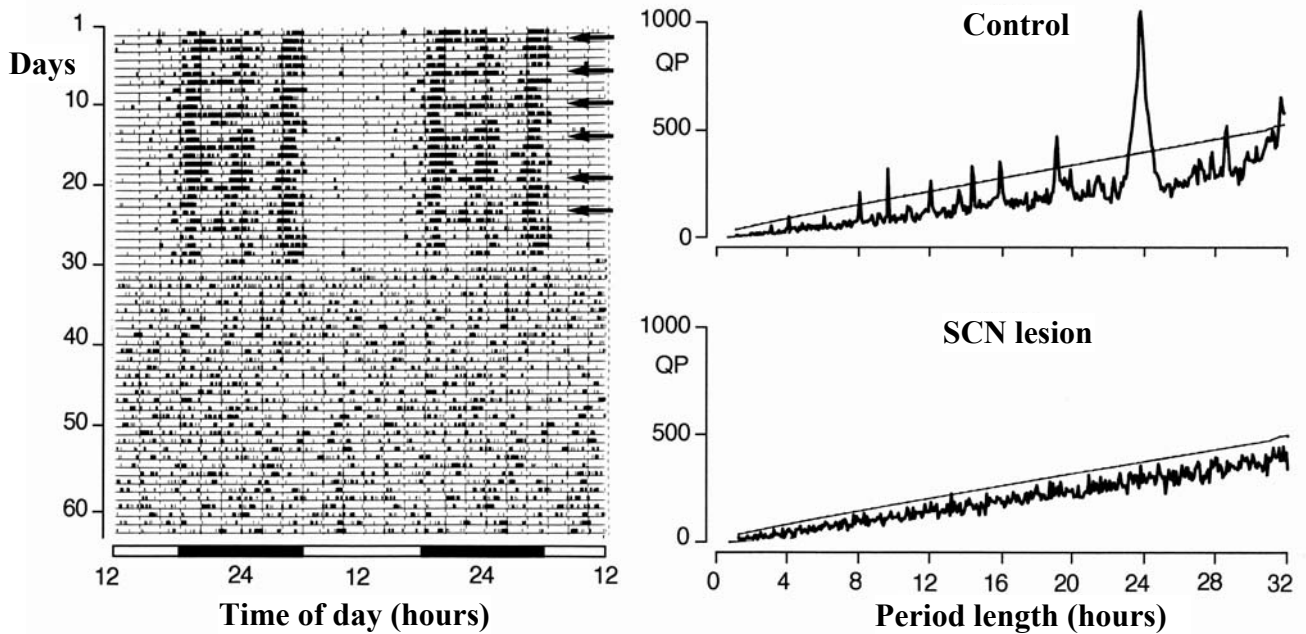

Figure 2. Locomotor activity rhythm of a rat after SCN lesion. The animal has an endogenous period of about 24 h before the lesion as shown by the periodogram. After SCN lesion (from day 30 until day 60), the locomotor activity rhythm disappears. (modified from Wollnik and Turek, 1989).

II.1.2. Intrinsic circadian rhythms: electrophysiology and metabolism

An *in vivo* study demonstrated that the SCN are able to maintain a circadian rhythm of **spontaneous electrical activity** even when they were isolated from other brain structures (Inouye and Kawamura, 1979). Moreover, this rhythm is maintained in SCN slices (Green and Gillette, 1982; Shibata *et al.*, 1982) as well as in isolated SCN cells (Welsh *et al.*, 1995) with a peak occurring during the subjective day and a trough during the subjective night. This electrical rhythm can persist for several weeks (Bos and Mirmiran, 1990).

Another intrinsic circadian rhythm has been pointed out. Indeed, there is a circadian rhythm for the **metabolic activity** of the SCN, shown by ^{14}C -labeled deoxyglucose uptake *in vivo* (Schwartz and Gainer, 1977) and *in vitro* (Newman and Hospod, 1986) with a maximum during the subjective day.

Moreover, Shibata *et al.* (1992) showed circadian changes of **protein synthesis** in rat SCN slices.

II.2. Cellular organization of the SCN

II.2.1. Localization and anatomy

The SCN is a pair of dense nuclei, localized adjacent to the third ventricle and above the optic chiasma (for review, Reuss, 1996; Ibata *et al.*, 1999; van Esseveldt *et al.*, 2000) (Fig. 3). In the rat, the rostro-caudal length of this structure is about 900 μm and the mediolateral and dorsoventral length is about 300 μm . It contains almost 16 000 small neurons (van den Pol, 1980). The SCN is one of the brain regions with the smallest neurons (7–11 μm soma diameter) and contains also a lot of astrocytes.

The SCN is classically divided in two subdivisions: the **dorsomedial region (dmSCN or shell)** and the **ventrolateral region (vlSCN or core)** (Moore, 1983; Leak *et al.*, 1999; Moore and Leak, 2001) (Fig. 4). The dmSCN is characterized by small, elongated neurons with large nuclei and few cell organelles. The neurons are tightly packed and interconnected via somato-somatic appositions, resulting in a chain of neurons (Van den Pol, 1980). Moreover, most of these neurons synthesize **vasopressin (VP)** (Vandesande *et al.*, 1975; Van

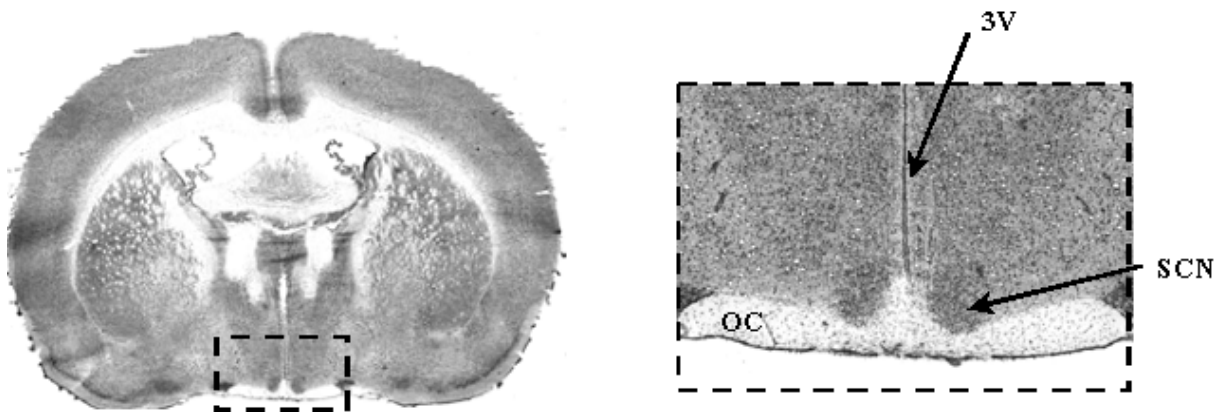

Figure 3. Localization of the SCN

On the left, coronal section of a hamster brain at the level of the SCN stained with violet cresyl. On the right, enlargement shows the SCN adjacent to the third ventricle (3V) and on the top of the optic chiasma (OC).

den Pol and Tsujimoto, 1985; Card *et al.*, 1988). The vlSCN contains a lower density of spherical neurons that have an organelle-rich cytoplasm (Van den Pol, 1980). The neuronal soma tend to be separated by glial cells, which completely enclose the synaptic junctions within the vlSCN (Güldner and Wolff, 1996; Serviere and Lavialle, 1996b; Maurel *et al.*, 2000), and communicate with each other through gap junctions (van den Pol, 1980; Welsh and Reppert, 1996). Neurons in the vlSCN are characterized by the synthesis of **vasoactive intestinal polypeptide (VIP)** (Card *et al.*, 1981).

II.2.2. Content in neuropeptides et neurotransmitters

This part deals only with neuropeptides and neurotransmitters synthesized in the SCN cells. The peptides localized in the afferent fibers will be described in the chapter “III. Entrainment of circadian rhythms”.

Two neurotransmitters are synthesized in the SCN: **GABA (γ -Amino-butyrique acid)** (Moore and Speh, 1993) and **glutamate** (Hermes *et al.*, 1996; Isobe and Nishihara, 2002; Perreau-Lenz *et al.*, 2003).

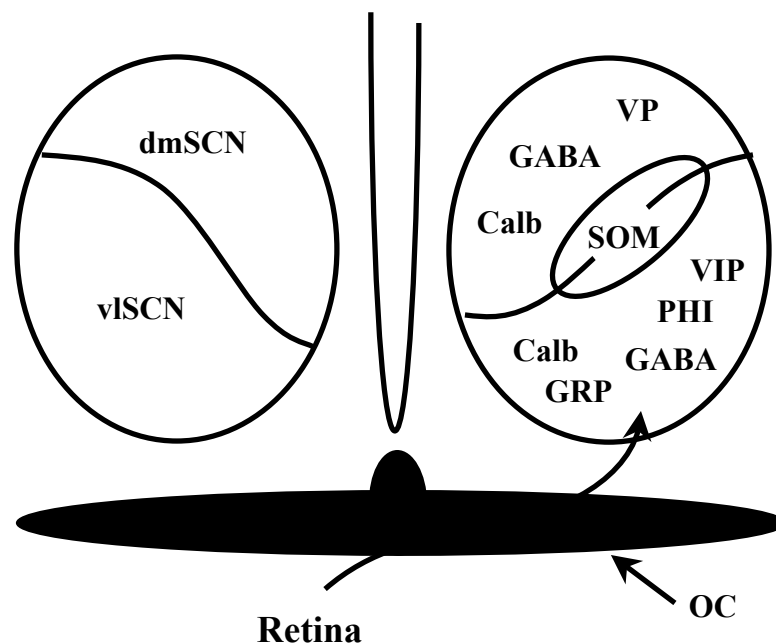

Figure 4. Subdivision of the SCN in dorsomedial (dmSCN) and ventrolateral (vlSCN) regions. Content in different neuropeptides. Calb: Calbindin; GABA: g-Aminobutyric acid; GRP: Gastrin releasing peptide; OC: Optic chiasm; PHI: Peptide isoleucine histidine; SOM: Somatostatin; VP: Vasopressin

Several neuropeptides have found to colocalize: VP colocalizes with enkephalin (Sakanaka *et al.*, 1990) whereas VIP and **peptidine histidine isoleucine (PHI)** (Card *et al.*, 1988) which are derived from a common precursor molecule, colocalize with **gastrin releasing peptide (GRP)** (Okamura *et al.*, 1986; Mikkelsen *et al.*, 1991). Moreover, it seems likely that all these cells can be inter-connected (Romijn *et al.*, 1997; LeSauter *et al.*, 2002).

A smaller proportion of **somatostatin (SOM)**-producing neurons was found in between the dmSCN and the vlSCN (Card *et al.*, 1988). These neurons do not colocalize with either VP or VIP (Tanaka *et al.*, 1996), and thus mark a distinct cell group.

Moreover, in hamsters and mice SCN, a local expression of an intracellular molecule **calbindin-D_{28k} (CalB)** (Silver *et al.*, 1996a) has been reported.

Other substances, that have been immunocytochemically reported to be produced in perikarya of rat SCN neurons, include for example **angiotensin-(1-7)** (Block *et al.*, 1988), **calcitonin gene-related peptide** (Park *et al.*, 1993) and **enkephalin** (Sakanaka *et al.*, 1990).

II.2.2.1. GABA

GABA is present in almost all SCN neurons (Moore and Speh, 1993), suggesting an important role in the circadian rhythmicity. It is therefore colocalized with nearly all neuropeptides of the SCN (Buijs *et al.*, 1995). Its synthesis enzyme, the **glutamic acid decarboxylase (GAD)** (that transforms glutamate in GABA), shows a circadian rhythm of mRNA expression (Huhman *et al.*, 1999). Moreover, both GABA levels and GAD activity in rats showed a circadian fluctuation in DD conditions (Aguilar-Roblero *et al.*, 1993) with maximal values occurring at the beginning of the night. Potential function for GABA will be detailed in chapter “II.3.2.: Cellular basis of the circadian rhythmicity: Mechanisms of cellular synchronization” and in chapter “III.2. The distribution of the circadian message”.

II.2.2.2. Vasopressin

VP is the most extensively studied neuropeptide of the SCN. As explained before, its expression is restrained to the dmSCN region (Fig. 5). VP protein levels (Tominaga *et al.*, 1992a) and VP mRNA levels (Cagampang *et al.*, 1994; Dardente *et al.*, 2004) cycle in the SCN under both LD and DD conditions with peak levels during the subjective day. The **VP V1a receptor (V1aR)** located on both VPergic and VIPergic SCN neurons (Dubois-Dauphin

et al., 1990) has been shown to express a diurnal rhythm under LD conditions, 12 h out of phase from that of VP with peak levels around midnight (Young *et al.*, 1993). Moreover, application of VP agonists to SCN cells *in vitro* increased the firing rate of about 50% of the neurons (Mihai *et al.*, 1994a), whereas application of a VPergic antagonists on the SCN cells *in vitro* induced a decrease in activity of about half of the VP-responsive neurons (Mihai *et al.*, 1994b).

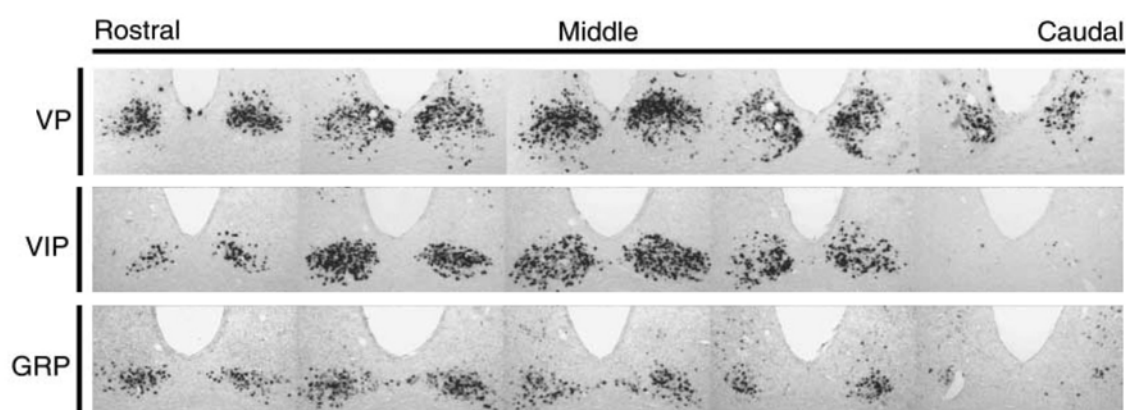

Figure 5. mRNA expression of VP, VIP and GRP after *in situ* hybridization of coronal rat brain sections at the level of the SCN (Modified from Dardente *et al.*, 2002).

II.2.2.3. Vasoactive Intestinal Peptide

VIP is only synthesized in the vlSCN region (Fig. 5). Levels of VIP mRNA and protein showed a diurnal rhythm under LD conditions with peak levels during the night (Takahashi *et al.*, 1989), but remained constant under DD conditions at least in the rat (Shinohara *et al.*, 1993). There are two VIP receptors: the **VPAC1** and the **VPAC2**, but only the latter is abundantly expressed in the rat SCN and shows a comparable biphasic pattern of expression in LD and DD with peaks at the end of the day and at the end of the night (Cagampang *et al.*, 1998). In addition, it is important to note that the VIP cells project strongly to the VP cells (Ibata *et al.*, 1993) and that thin varicose axons containing VIP are present throughout the SCN (Card *et al.*, 1981). VIP seems to be essential for the SCN cells coupling (see chapter: “II.3.2.: Cellular basis of the circadian rhythmicity: Mechanisms of cellular synchronization”) and synchronization to light (see chapter: “III.1.2.1.: Photic entrainment of the SCN”).

II.2.2.4. Gastrin-Releasing Peptide

As VIP, GRP is exclusively expressed in the vlSCN (Mikkelsen *et al.*, 1991) (Fig. 5). It is found to be colocalized with VIP (Romijn *et al.*, 1998). Levels of GRP also show a diurnal rhythm under LD conditions, which is however 12 h out of phase with the VIP rhythm (higher during the day than during the night) (Okamura and Ibata, 1994). However, in DD conditions, this rhythm is abolished at least in the rat (Shinohara *et al.*, 1993; Dardente *et al.*, 2004). The role of GRP is not clear since its application on SCN slices induced different effects depending on neurons (Tang and Pan, 1993). However, injected *in vivo* directly in the SCN, GRP induced delays of the locomotor activity rhythm at the beginning of the subjective night and advances at the end of the subjective night (Piggins *et al.*, 1995), suggesting an implication of GRP in the synchronization of the SCN to light (Dardente *et al.*, 2002).

II.2.2.5. Somatostatin

SOM is expressed in a separate group of cells located in between the large pool of VPergic and VIPergic neurons (Tanaka *et al.*, 1996). The innervation's field of the SOMergic neurons is confined within the SCN (Daikoku *et al.*, 1992a) with its receptors mainly present in the vlSCN (Breder *et al.*, 1992). The expression of SOM showed a circadian variation with a peak during the day in the rat (Fukuhara *et al.*, 1993; Nishiwaki *et al.*, 1995) whereas in the hamster, its expression was constant (Duncan *et al.*, 2001). Application of SOM on SCN slices induced the same effects on rhythms as those induced by GRP and VIP (Hamada *et al.*, 1993). However, its precise role in circadian rhythms has not been deeply studied so far.

II.2.2.6. Calbindin-D_{28K}

In the hamster and the mouse, the CalB cells are densely packed within a discrete region in the vlSCN (Silver *et al.*, 1996a; Menet *et al.*, 2003). The cells receive afferent fibers containing neuropeptides like substance P, VIP and GRP, but not AVP (LeSauter *et al.*, 2002). However, in the rat, these cells are more sparse (Mahoney *et al.*, 2000). SCN cells that produce CalB seem to be very important in the genesis and control of the locomotor activity rhythm in the hamster. Indeed, partial lesion of CalB neurons induced a loss of the locomotor activity rhythm and the persistence of the rhythm was correlated with the number of CalB

cells left. Moreover, when SCN neurons were regrafted after this lesion, the higher number of CalB neurons were contained, the better the locomotor activity rhythm was restored (LeSauter and Silver, 1999). However, these CalB cells do not express a circadian rhythm of electrical activity, whereas adjacent cells do (Jobst and Allen, 2002).

II.3. Rhythm genesis in the SCN

Most SCN neurons are autonomous circadian pacemakers. Indeed, single SCN neurons dispersed at low density onto a multielectrode array expressed firing rate patterns with different circadian periods (Welsh *et al.*, 1995). Moreover, the application of tetrodotoxin (TTX), known to block action potentials, did not change the phase of electrical activity rhythm of a SCN neuron.

This raised the question of the origin of this rhythm and the way it is built.

The transplantation study using the tau mutant hamster (Ralph and Menaker, 1988) as well as the vasopressin-deficient homozygous Brattleboro rat (Boer *et al.*, 1999) gave strong arguments for a genetically determined clock in mammals. In addition, this feature has been already demonstrated in insects (Pittendrigh, 1967).

II.3.1. Molecular basis of the circadian rhythmicity

The identification of genes which appear to be crucial for circadian rhythmicity (“**clock genes**”) in the fruit fly *Drosophila melanogaster* and the fungus *Neurospora crassa* has prompted many investigators to search for mammalian homologs.

Figures 6 and 7 summarize the effect of different clock genes mutations on locomotor activity rhythm. The patterns of clock gene expression are recapitulated in Table 1. Figure 8 illustrates the molecular machinery of the SCN.

The discovery of the first clock gene in mammals, named ***Clock***, was provided by Vitaterna *et al.* (1994) in mice. Eleven clock genes have been revealed so far: ***Per1***, ***Per2***, ***Per3***, ***Cry1***, ***Cry2***, ***Dec1***, ***Dec2***, ***Clock***, ***Bmal1***, ***Reverb α*** and ***Ror α*** . The related mRNAs and proteins interact and form **one positive, one negative and the Rev-erb α transcriptional and post-translational autoregulatory loops** (Fig. 8). Moreover, **Casein kinase I ϵ (CKI ϵ)**, is also implicated in the regulation of these loops. The positive loop induces the rhythmic

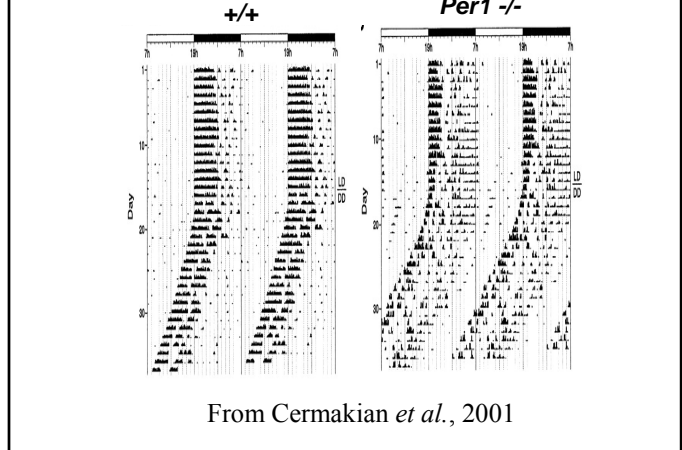
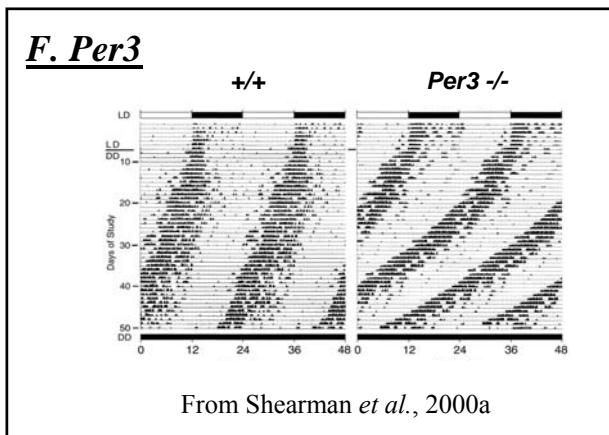
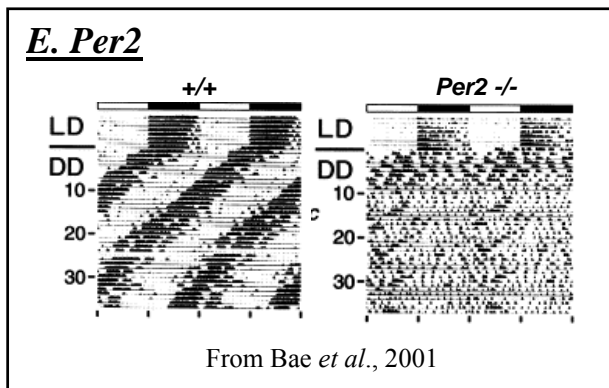
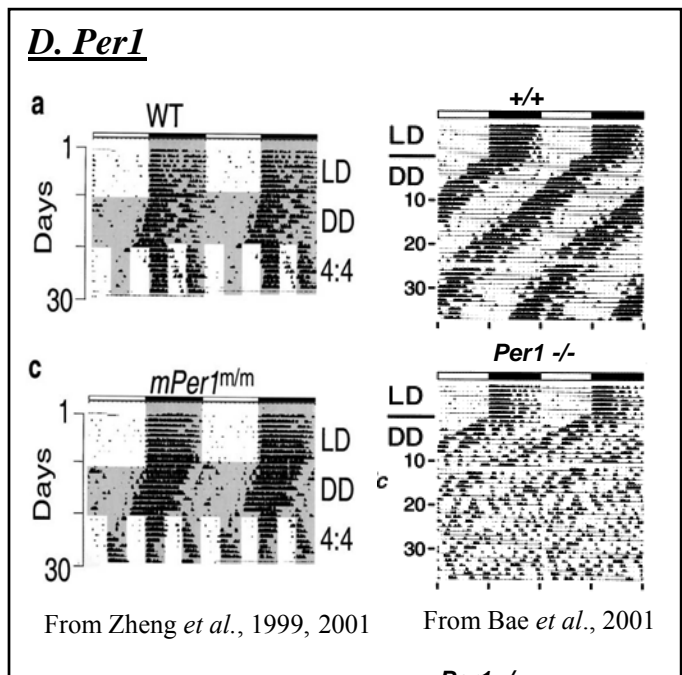
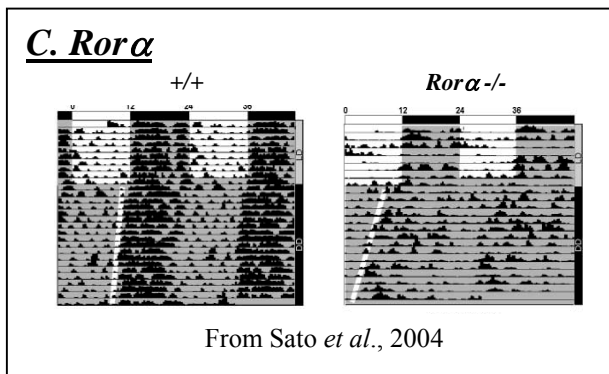
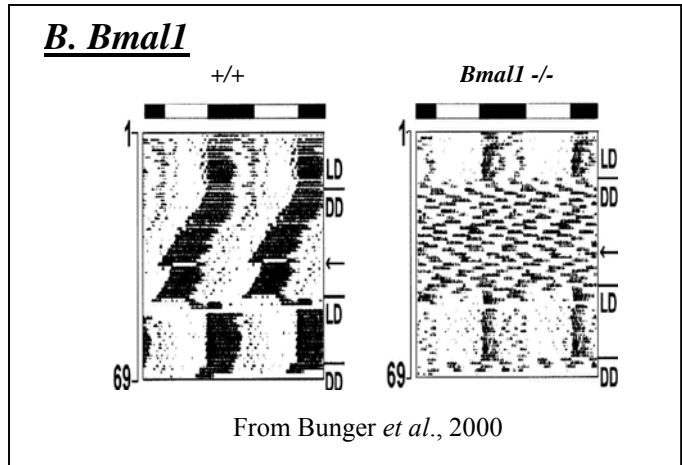
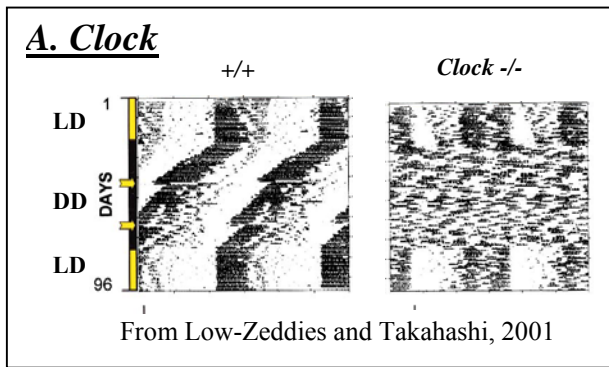

Figure 6. Locomotor activity rhythm of KO and mutant mice for clock genes

expression of other genes, named **clock-controlled genes** (*ccg*) that are direct outputs of this molecular machinery, that is the case for VP gene.

II.3.1.1. The positive loop

This loop is composed of three transcription factors: CLOCK, BMAL1 and ROR α .

CLOCK (Circadian Locomotor Output Cycles Kaput) belongs to the **bHLH** (basic Helix-Loop-Helix) – **PAS** (Period-Arnt-Sim) domain transcription factors family (King *et al.*, 1997; Hogenesch *et al.*, 1998). bHLH is a protein domain which allows DNA binding. PAS domains allow dimerization with other proteins containing this domain. Mutant mice for *Clock*, generated by mutagenesis (Takahashi *et al.*, 1994), are arrhythmic in DD (Vitaterna *et al.*, 1994) (Fig. 6A). Moreover, in *Clock* mutant mice, the expression of other clock genes, like *Per* (Oishi *et al.*, 2000), *Cry* (Kume *et al.*, 1999) or *Dec* (Butler *et al.*, 2004) is strongly reduced, providing the evidence that *Clock* is an important part of the positive loop. mRNA levels of *Clock* in the SCN of mice (Shearman *et al.*, 1999) and rats (Oishi *et al.*, 1998), as well as its protein levels (Maywood *et al.*, 2003) are constant in DD (Table 1).

BMAL1 (Brain and Muscle Arnt Like protein 1), discovered by Ikeda and Nomura (1997), is also called MOP3 (Hogenesch *et al.*, 1998). It is included in the same transcription factor family as CLOCK. **Knock-Out (KO)** mice for *Bmal1* are arrhythmic in DD but rhythmicity in LD is hardly disturbed (Bunger *et al.*, 2000) (Fig. 6B). In addition, in *Bmal1* KO mice, *Per1* and 2 expressions are arrhythmic and low (Bunger *et al.*, 2000) providing a strong argument for a major role of *Bmal1* in the positive loop. The expression of *Bmal1* is rhythmic and the peak of mRNA level appears at CT 15-18 in opposite phase with that of *Per* genes (Honma *et al.*, 1998a; Oishi *et al.*, 1998) (Table 1). The protein levels peak at the end of the subjective night (Maywood *et al.*, 2003). BMAL1 dimerizes with CLOCK to increase the expression of genes with E-Box (an enhancer element located in the promoter of the gene), such as *Per* (Gekakis *et al.*, 1998), *Cry* (Kume *et al.*, 1999), *Dec* (Hamaguchi *et al.*, 2004; Kawamoto *et al.*, 2004), *Rev-erb α* (Preitner *et al.*, 2002) and *ccg* (Fig. 8).

Recently, Sato *et al.* (2004) showed that **ROR α** , a retinoid-related orphan receptor, activates the expression of *Bmal1* through its binding to the **RORE** (Retinoid-related Orphan Response Element) sequence located in the *Bmal1* promoter. KO mutant mice for *Rora* showed perturbations of the locomotor activity rhythm and a decrease of *Bmal1* expression

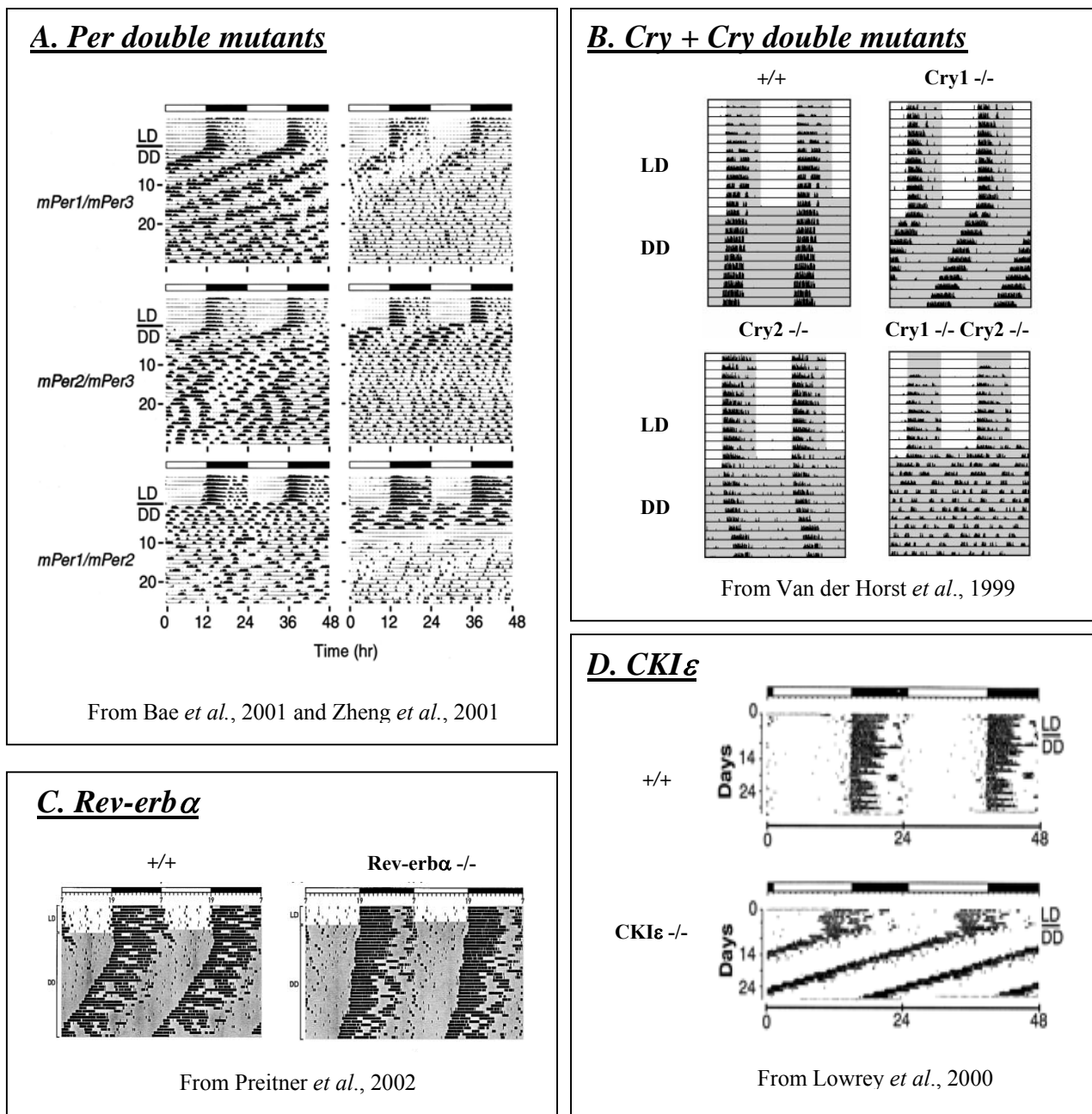

Figure 7. Locomotor activity rhythm of KO and double mutant mice for clock genes

(Sato *et al.*, 2004), demonstrating thus the positive effect of ROR α on the expression of *Bmal1* (Fig. 6C). The mRNA levels of Ror α were expressed with a circadian rhythm having a peak around CT 8-12 (Ueda *et al.*, 2002) (Table 1). It is very likely that the CLOCK-BMAL1 dimer has a direct effect on *Ror α* expression and that *Ror α* is preceded by an E-Box, despite the fact that it has not been clearly demonstrated (Fig. 8).

II.3.1.2. The negative loop

This loop is composed of three families of transcription factors: PER (with PER1, PER2 and PER3), CRY (with CRY1 and CRY2) and DEC (DEC1 and DEC2).

PER (for Period) proteins have a PAS domain, but no bHLH domain contrary to CLOCK and BMAL1. Moreover, it has a **NLS** (Nuclear Localization Signal) (Vielhaber *et al.*, 2000) and a **CLD** (Cytoplasmic Localization Domain).

Per1, also initially called *Rigui*, has a circadian rhythm of mRNA expression in DD in mice (Sun *et al.*, 1997; Tei *et al.*, 1997), rats (Yan *et al.*, 1999) and hamsters (Messenger *et al.*, 1999) with a peak between CT 4 and 8. It seems to be mostly expressed in VP-ir cells of the dmSCN (Dardente *et al.*, 2002). PER1 is also produced in SCN with a circadian rhythm with a maximum at CT 10-16 (Hastings *et al.*, 1999) (Table 1). Diverse phenotypes for locomotor activity have been described for the KO mice (*Per1* *-/-*) (Fig. 6D). For Cermakian *et al.* (2001) and Zheng *et al.* (2001), the KO mice still have a locomotor activity rhythm in DD, but τ is shorter and less stable than for wild-type mice. On the opposite, the team of Bae *et al.* (2001) showed that KO mice for *Per1* remain rhythmic only for several days in DD, and then become arrhythmic.

The gene **Per2** was discovered by sequence homology with *Per1* (Shearman *et al.*, 1997) and expresses a circadian rhythm of mRNA levels in mice (Takumi *et al.*, 1998), rats (Yan *et al.*, 1999) and hamsters (Maywood *et al.*, 1999) with a peak at CT 8-12. As *Per1*, *Per2* mRNA is mostly expressed in VP-ir cells of the dmSCN (Dardente *et al.*, 2002). The expression of PER2 takes place between CT 10 and 16 (Field *et al.*, 2000) (Table 1). KO *Per2* mutant mice placed in DD displayed first a shorter τ and then became arrhythmic (Bae *et al.*, 2001) (Fig. 6E).

Per3, also discovered by sequence homology with *Per1* (Zylka *et al.*, 1998), expresses a rhythm of mRNA levels in DD in mice (Zylka *et al.*, 1998) and hamsters (Horikawa *et al.*,

Gene	mRNA		Protein	
	Profile	Time of peak	Profile	Time of peak
<i>Clock</i>	Constant	-	Constant	-
<i>Bmal1</i>	Rhythmic	CT 15-18	Rhythmic	CT 0-8
<i>Rora</i>	Rhythmic	CT 8-12	n.d.	-
<i>Per1</i>	Rhythmic	CT 4-8	Rhythmic	CT 10-16
<i>Per2</i>	Rhythmic	CT 8-12	Rhythmic	CT 10-16
<i>Per3</i>	Rhythmic	CT 6-9	Rhythmic	CT 10
<i>Cry1</i>	Rhythmic	CT 8-12	Rhythmic	CT 12-16
<i>Cry2</i>	Rhythmic or not	(CT 8-12) [§]	Rhythmic	CT 12-16
<i>Dec1</i>	Rhythmic	CT 6-12	n.d.	-
<i>Dec2</i>	Rhythmic	CT 8-14	n.d.	-
<i>Rev-erba</i>	Rhythmic	CT 2-6	n.d.	-
<i>Cklε</i>	Constant	-	n.d.	-

n.d.: not determined

Table 1. Summary of clock genes expression pattern in the SCN

2000) with a peak at CT 6-9 as well as a circadian rhythm of protein levels 4 hours after (CT 10) (Field *et al.*, 2000) (Table 1). The KO mutation of *Per3* induces a τ shortening of about 30 min (Shearman *et al.*, 2000a) (Fig. 6F).

Thus, the expression of PER proteins oscillates in DD in SCN in an opposite phase with BMAL1, reinforcing the model of positive and negative regulation loops. Double mutant mice for the *Per* genes have been made in order to investigate a potential redundancy between these three genes. The phenotype of the double KO mutant *Per1-2* that became immediately arrhythmic in DD (Zheng *et al.*, 2001) is more severe than that of the KO mutant *Per1-3* or *Per2-3* (Bae *et al.*, 2001) (Fig. 7A). This result provides a strong argument in favor of a redundancy of the gene *Per3*, but not of *Per1* and 2.

CRY (Cryptochrome) proteins, first identified in plants, are **flavoproteins** (that mediate repairment of DNA) lacking detectable photolyase activity (Cashmore *et al.*, 1999). **Cry1** is rhythmically expressed in DD with a peak of mRNA level at the day-night transition (Miyamoto and Sancar, 1999). For **Cry2** the data are less clear. mRNA levels may be constant (Kume *et al.*, 1999) or rhythmic with a peak at the day-night transition (Okamura *et al.*, 1999). The expression of CRY1 and CRY2 follows a circadian rhythm and is maximal at the beginning of the subjective night (Kume *et al.*, 1999) (Table 1). In comparison with the wild-type mice, KO *Cry1* mutant mice and *Cry2* mutant mice continue to have a rhythmic locomotor activity rhythm in DD (Thresher *et al.*, 1998; van der Horst *et al.*, 1999). On the contrary, double KO mutant for *Cry1-2* are arrhythmic in DD (van der Horst *et al.*, 1999), demonstrating a redundant function of these two genes (Fig. 7B). Moreover, this double KO led to a constant high expression of *Per1* and 2 (Okamura *et al.*, 1999), clearly implicating *Cry 1* and 2 in the negative regulation loop.

All PER and CRY proteins can interact with each other to form heterodimers that inhibit the positive effect of CLOCK-BMAL1 on the expression of genes with E-box (Griffin *et al.*, 1999; Kume *et al.*, 1999) (Fig. 8). PER-CRY dimmers seem to inhibit the effect of CLOCK-BMAL1 by direct binding, preventing CLOCK-BMAL1 to interact with DNA (Kume *et al.*, 1999; Shearman *et al.*, 2000b). The translocation of PER to the nucleus needs the presence of CRY as well as post-translational modifications, such as phosphorylation (Lee *et al.*, 2001). Moreover, the dimerization of PER and CRY has another important effect: it stabilizes and avoids the rapid degradation of these proteins (Lee *et al.*, 2001).

DEC (Differentially expressed in chondrocytes) proteins (DEC1 and 2), discovered by Honma *et al.* (2002), encode bHLH transcription factors. However, they do not have a PAS domain. Indeed, they can bind to the same DNA sequences, such as CLOCK-BMAL1, but cannot activate transcription. Thus, it seems likely that DEC1 and 2 could be competitive inhibitors of CLOCK-BMAL1. In addition, DECs can bind BMAL1 and therefore prevent the formation of the CLOCK-BMAL1 (Honma *et al.*, 2002) (Fig. 8). Both genes showed a circadian rhythm with a peak during the subjective day (CT 6-12 for *Dec1* mRNA and CT 8-14 for *Dec2* mRNA) (Honma *et al.*, 2002) (Table 1).

II.3.1.3. The Rev-erb α loop

This loop contains an orphan nuclear receptor: **REV-ERB α** . This protein is also a transcription factor which acts on RORE sequences of *Bmal1* and inhibits its expression (Preitner *et al.*, 2002). Indeed, REV-ERB α is in competition with ROR α for the regulation of expression of *Bmal1* (Fig. 8).

KO *Rev-erb α* mutant mice placed in DD, still displayed a rhythmicity of the locomotor activity in comparison with wild-type mice (Fig. 7C), but no more rhythmicity of the expression of *Bmal1*. In fact, the expression of *Bmal1* was, in these conditions, high and constant (Preitner *et al.*, 2002) providing evidence that REV-ERB α is implicated in a negative regulation loop.

The mRNA levels of *Rev-erb α* show a rhythmic expression with a maximum at CT 4 (Onishi *et al.*, 2002) (Table 1).

II.3.1.4. Post-translational mechanisms

The most studied post-translational mechanism is phosphorylation.

CKI ϵ is specially important for phosphorylation mechanisms. It can phosphorylate PER1, PER2 (Lowrey *et al.*, 2000), CRY1, CRY2 and BMAL1 (Lee *et al.*, 2001). In the hamster, spontaneous mutants for this enzyme, named tau mutants, show a shortening of the endogenous period (20 h mean period for the homozygote mutants and 22 h mean period for the heterozygote mutants) (Fig. 7D) (Ralph and Menaker, 1988). Furthermore, the phosphorylation efficiency is lower in these mutants (Lowrey *et al.*, 2000).

Casein kinase I δ is another kinase implicated in phosphorylation mechanisms in the master clock. This homolog of CKI ϵ can phosphorylate *in vitro* PER1, PER2 and PER3 (Akashi *et al.*, 2002). Moreover, the mitogen-activated protein kinase (**MAP kinase**) can also phosphorylate BMAL1 *in vitro* (Sanada *et al.*, 2002).

The phosphorylation of CLOCK and BMAL1 is important for their translocation in the nucleus (Lee *et al.*, 2001) and their transcriptional activity (Eide *et al.*, 2002; Sanada *et al.*, 2002). Apparently, phosphorylated CLOCK-BMAL1 dimer is continuously fixed on the E-box of *Per1* promoter (Lee *et al.*, 2001). The phosphorylation of PER proteins induces their ubiquitination and degradation by proteasomes (Yagita *et al.*, 2002). Moreover, it has been shown that the phosphorylation of PER1 by CKI ϵ leads to its cytoplasmic retention (Vielhaber *et al.*, 2000). In contrast to PER1, CRY proteins bind, stabilize and avoid the degradation of PER2 (Lee *et al.*, 2001). PER proteins are a link between CRY proteins and CKI ϵ /CKI δ in order to form the multimer CRY-PER-CKI and to induce the phosphorylation of CRY proteins (Akashi *et al.*, 2002; Eide *et al.*, 2002). Subsequently, this multimer is translocated in the nucleus in order to inhibit the transcription induced by CLOCK-BMAL1 (Lee *et al.*, 2001).

II.3.2. Cellular basis of the circadian rhythmicity: Mechanisms of cellular synchronization

Each SCN neuron is a pacemaker. However, the question of the genesis of the circadian message, based on cellular rhythmicity, remains open.

The coupling of SCN neurons seems essential, since the locomotor activity rhythm period reflects the mean of all electrical activity periods of the SCN neurons (Liu *et al.*, 1997). In this study, authors have recorded electrical activity rhythm of single SCN neurons of tau homozygotes and heterozygotes mutant hamster and demonstrated that the period in the whole animal was the mean of periods of all cells. Similar results were obtained in *Clock* mutant mice (Herzog *et al.*, 1998). Moreover, these authors showed that dispersion of endogenous period is reduced when interconnection between neurons increases. This has been confirmed by the fact that SCN cell explants that conserve tissue integrity tend to have the same phase (identical electrical activity periods) whereas dissociated SCN cells have a larger dispersion of period activities (Herzog *et al.*, 1998). Nevertheless, the mechanisms of cellular synchronization are still unclear.

The most classical coupling mechanism between neurons is the **synapse**. Indeed, an application of TTX on a couple of SCN neurons for several days can desynchronize their previous synchronized electrical activities, demonstrating the importance of action potentials (Honma *et al.*, 2000). This result was further corroborated by Yamaguchi *et al.* in 2003. These authors used SCN slice cultures from neonatal transgenic mice carrying the *Per1*-promoter-driven luciferase reporter gene, in order to follow the rhythmic expression of *Per1* as a marker of the neurons circadian rhythm. They showed that an application of TTX on these organotypic SCN cultures broke harmonized expression of the luciferase rhythm. This study demonstrates that **Na⁺-dependent action potentials** are needed for establishing the synchronized program of clock gene expression between cells.

It is not clear which neurotransmitter(s) could convey the rhythmic information from cell to cell. Nevertheless, different reports give arguments towards an implication of **GABA** in this synchronization. *In vitro* administration of GABA on SCN cells induced an inhibition of the SCN electrical activity (Nishino and Koizumi, 1977; Liou and Albers, 1990). Moreover, GABA could have a differential action on the SCN neurons depending on the time of day, because GABA stimulated SCN cells during the day and inhibited them during the night (Wagner *et al.*, 1997). In addition, GABA induced a modification of electrical activity rhythm on dissociated SCN cells similar to that induced by light on locomotor activity (Liu and Reppert, 2000). These authors further demonstrated that SCN neurons having out of phase electrical activities could be resynchronized by an application of GABA, via the GABA_A receptor. Furthermore, in cultured rat suprachiasmatic neurons, two neurons which presented the same electrical activity rhythm were found to be in fact connected by GABAergic synapses (Shirakawa *et al.*, 2000).

Another type of communication between neurons could mediate SCN neurons coupling: there are **gap-junctions**. Some authors have shown the presence of connexons between neurons (Shinohara *et al.*, 2000) whereas other authors have shown connexons only between astrocytes (Welsh and Reppert, 1996). Thus, **glia** could be involved in the mechanisms of cells coupling. Indeed, circadian variation of the astrocytes processes length has been described with a maximal extension during the day (Lavialle and Serviere, 1993). Moreover, astrocytes formed a lot of contacts with SCN neurons (Tamada *et al.*, 1998). Glial processes are denser in the vlSCN and make contacts with neurons containing VIP. In the dmSCN, VP cells are partially included in glial processes. Actually, it has been suggested that astrocytes could be involved in the regulation of extracellular concentration of K⁺ and Ca²⁺ (van den Pol

et al., 1992) and the release of neurotransmitters in the extracellular space (Barbour *et al.*, 1989). Moreover, astrocytes can release different diffusible factors, like NO (Nitric Oxide) or arachidonic acid, that can influence neurons activity. For example, arachidonic acid decreases glutamate reuptake from extracellular space (Barbour *et al.*, 1989). To summarize, interaction between neurons and glia cells in SCN seems to be very important for cells coupling (Prosser *et al.*, 1994a).

Another important aspect of the cellular synchronization is the **heterogeneity of the SCN**. Indeed, one quarter of the SCN cells do not show circadian oscillation of electrical activity (Honma *et al.*, 1998b). According to Nakamura *et al.* (2001), the dmSCN contains a higher percentage of neurons having an endogenous rhythmicity, compared to the vlSCN. Moreover, the study of Yamaguchi *et al.* (2003), using SCN slice cultures from neonatal transgenic mice carrying the *Per1*-promoter-driven luciferase reporter gene, gives more arguments for the idea that the SCN is in fact a heterogenous cellular assemblage of autonomous cellular oscillators acting in concert. Indeed, over the course of the daily cycle, the luminescence signal first appears in the dmSCN and then spreads out to the central and then to the ventral part of the SCN. Shinohara *et al.* proposed in 1995 that the SCN are composed of two distinct oscillators. These two oscillators would control VP and VIP release which are in opposite phase. They demonstrated that the phase relationship between the release of these two neuropeptides was stable until the application of an antimetabolic product that reduces glia cells number. Thus, glia seems to keep these two oscillators synchronized. Other results on clock genes are consistent with the idea that the SCN is a heterogenous structure. Rhythmic expression of *Per1* and *Per2* is only detected in the dmSCN whereas in vlSCN *Per1* and *Per2* expression is almost constant (Yan *et al.*, 1999). Colocalization experiments have shown that rhythmic expression of *Per1* and *Per2* are mainly localized in the VP neurons (Dardente *et al.*, 2002). These results led to the idea that only the dmSCN, and in particular VP neurons, contains real pacemakers and that the vlSCN, and more precisely VIP neurons, is not so essential for rhythm generation. Furthermore, it seems that the building of the circadian message is even more complicated. Indeed, *Vipr2*^{-/-} mice carrying a mutation for the VIP receptor (VPAC₂) gene show an arrhythmicity of the locomotor activity (Harmar *et al.*, 2002). This arrhythmicity is due to a desynchrony of the SCN neurons which are pacemakers and to a loss of rhythm of the other SCN neurons. This was demonstrated by the recording of the electrical activity rhythm in SCN slices in KO mice for VIP gene (*Vip*^{-/-}) and for VPAC₂ gene (*Vipr2*^{-/-}) (Aton *et al.*, 2005). VIP seems to be an

essential neuropeptide of the SCN, involved in the rhythm generation as well as in the SCN neurons synchronization.

Thus, the SCN contains the master clock and is a specific and heterogeneous brain structure. Most of its neurons are pacemakers that generate a circadian rhythm based on molecular mechanisms. However, the global rhythm of the SCN is the result of intercellular synchronizations that are likely mediate by neuropeptides and/or GABA.

III. Entrainment of circadian rhythms

The SCN is able to generate an endogenous rhythmicity with a period near 24 h. However, in order to be in phase with the environment, the SCN has to be **synchronized** by external factors named **Zeitgebers**. I will only describe the mechanisms of daily synchronization. The mechanisms of seasonal synchronization will not be discussed here. The most important Zeitgeber is the light-dark (LD) cycle (For review: Morin, 1994). But, the **photic factor** is not the only Zeitgeber able to entrain the clock. Other synchronizers, named **non-photoc factors**, like forced locomotor activity, restricted feeding or the application of drugs, can entrain circadian rhythms (For review: Challet and Pévet, 2003). Zeitgebers can change the **phase** of the circadian rhythms, but also their **period**. Nevertheless, the rhythmic and synchronized message generated by the SCN has to be distributed to the rest of the body in order to entrain all physiological functions of the body.

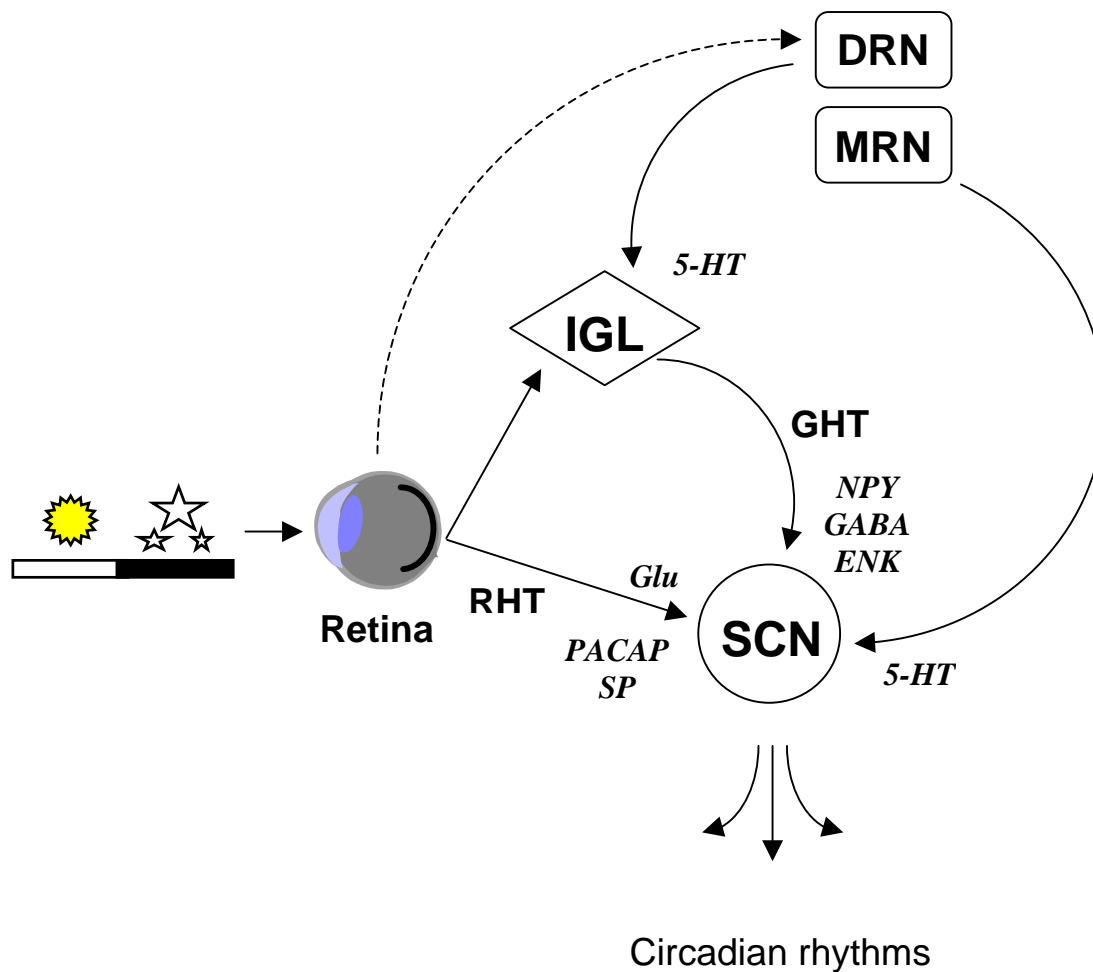

Figure 9. The most important afferences to the SCN.

5-HT: serotonin, DRN: dorsal raphe nucleus, GABA: γ -aminobutyric acid, GHT: geniculohypothalamic tract, Glu: glutamate, IGL: intergeniculate leaflet, MRN: median raphe nucleus, NPY: neuropeptide Y, PACAP: pituitary adenylate cyclase-activating peptide, RHT: retinohypothalamic tract, SP: substance P.

III.1. The daily entrainment of the SCN

The SCN receives environmental information through different afferences. In this chapter, I will first detail the different afferences of the SCN, conveying the information of these external factors (Fig. 9). Then, I will explain the mechanisms of entrainment discovered until now.

III.1.1. Afferences of the SCN

Neuronal projections from other regions of the central nervous system to the SCN are restricted mainly to its ventral portion, the vlSCN and more precisely to VIP neuronal elements. Thus, the different regions of the SCN seem also to have different functions, the vlSCN being an important SCN region for entrainment.

III.1.1.1. The retinohypothalamic tract (RHT): the main photic afference

The most important time cue is light, which is transmitted to the brain by retinal afferences (Moore and Lenn, 1972; Fig. 9 + 10). The transport of this information to the SCN begins in the retina since an ocular enucleation abolishes photic entrainment (Foster *et al.*, 1993).

Rods and **cones** seem not to be critical for SCN entrainment by light. Indeed, mice mutant for both rods and cones (rodless + coneless) were still entrained, for example, their locomotor activity rhythm still showed circadian responses to light (Freedman *et al.*, 1999). Moreover, it has been demonstrated that a little subpopulation of retinal ganglion cells is sensitive to light (Berson *et al.*, 2002). These cells that also set up the beginning of the RHT, contain an opsin-based photopigment named **melanopsin** (Gooley *et al.*, 2001; Hattar *et al.*, 2002). Its absorption characteristics are consistent with the light wavelength, ranging from 480–511 nm (blue light) that is the most effective for entrainment (Thapan *et al.*, 2001; Hattar *et al.*, 2002). Moreover, ganglion cells that synthesize melanopsin are intact in rodless/coneless mice (Semo *et al.*, 2003). However, KO mutations for melanopsin did not block the light entrainment of the master clock, although circadian responses to light decreased in amplitude (Ruby *et al.*, 2002). Nevertheless, the triple KO mutation for

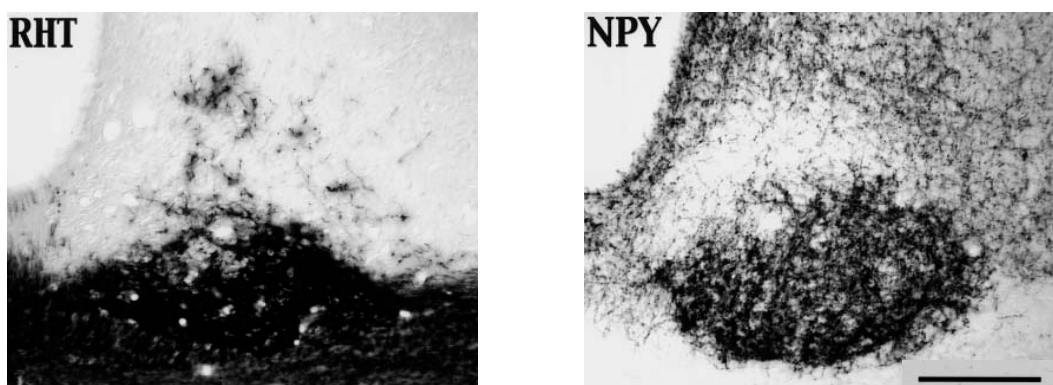

Figure 10. The RHT and the GHT: two afferences of the SCN.

Transverse rat SCN slices. Anterograde tracer injected in the retina visualizes the RHT. NPY immunocytochemistry enables GHT visualization (Modified from Moore et al., 2002). Scale bar = 100 μ m.

melanopsin and for two important elements of the transduction cascade of rods and cones induced the loss of circadian rhythms entrainment (Hattar *et al.*, 2003). **Thus, it seems likely that the rods, the cones and the ganglion cells of the retina are partially redundant in terms of entrainment.**

The RHT originates in a little subpopulation of retinal ganglion cells that synthesize melanopsin (Moore *et al.*, 1995) and constitutes only a small percentage (0.1%) of the optic nerve fibers (Provencio *et al.*, 1998). The integrity of the RHT is necessary for entrainment but not for generation of rhythms. Indeed, KO mice for *math5* (necessary for retina development), that lack an intact RHT, still showed circadian rhythms (Wee *et al.*, 2002).

Moreover, it is important to precise that the RHT convey only “circadian vision”, since a selective lesion of the RHT fibers leads to the loss of entrainment, but not of vision (Johnson *et al.*, 1998a). Axons of the retinal ganglion cells directly project to VIP neuronal elements, demonstrated by double-labeling immunocytochemistry (Ibata *et al.*, 1989; Tanaka *et al.*, 1993). Fibers of the RHT also project to different structures of the hypothalamus and the thalamus (Johnson *et al.*, 1998b). Moreover, the RHT projects to an important structure of the thalamus, known to be part of the circadian system, the **intergeniculate leaflets (IGL)** (see chapter ”III.1.1.2. The geniculohypothalamic tract (GHT)”). In the rat, some RHT fibers

also project to the **dorsal raphe nucleus (DRN)** (Kawano *et al.*, 1996; see chapter “IV. The serotonergic system”).

Another question concerns the neurotransmitters used by the RHT. One of the RHT neurotransmitter, excitatory in nature, is **glutamate** (Castel *et al.*, 1993). Glutamate increases the electrical activity of SCN neurons and thus exerts the same effects as stimulation of the optic nerve or as photic stimulation of the eyes (Meijer *et al.*, 1993). Moreover, the RHT contains a neuropeptide, **PACAP** (Pituitary Adenylate Cyclase-Activating Peptide) that seems to be important in entrainment mechanisms (Hannibal *et al.*, 1998; Harrington *et al.*, 1999; Hannibal *et al.*, 2000). **Substance P (SP)** was proposed to be another neuropeptide of the RHT since enucleation reduced sensivity of SP fibers in the SCN (Takatsuji *et al.*, 1991). Actually, its application *in vitro* modified the phase of the electrical activity rhythm of the SCN (Shibata *et al.*, 1994) and *in vivo* injections changed the phase of the locomotor activity rhythm (Challet *et al.*, 1998a).

III.1.1.2. The geniculohypothalamic tract (GHT)

The second major afference to the SCN originates in the **IGL** of the thalamus (Fig. 9; Moore and Card, 1994). This structure is a thin nucleus located between the dorsal and ventral parts of the lateral geniculate nucleus. It can be divided in three parts (Fig. 11):

- A rostral part, that forms a triangle
- A medial part, that forms a leaflet
- A caudal part, that continues more medially and ventrally

The IGL is characterized by immunoreactivity (ir) to **neuropeptide Y (NPY)**, **GABA** and **enkephaline (ENK)**. NPY and ENK neurons seem to be colocalized in 50% of all IGL cells. GABA is synthesized in almost all IGL neurons (Moore and Speh, 1993). Thus, IGL cells that synthesize NPY and ENK, also contain GABA.

IGL receives a direct projection from the **retina**. In the hamster, some of the axons of retinal ganglionic cells bifurcate and project to both the SCN and IGL (Pickard, 1985). Moreover, other important afferences to the IGL are coming from the **controlateral IGL** (Mikkelsen, 1992) and the **DRN** (Meyer-Bernstein and Morin, 1996). Additional projections are coming from visual centers, like the pretectum (Morin and Blanchard, 1998), from hypothalamic nucleus, for example retrochiasmatic area (Card and Moore, 1989) or from

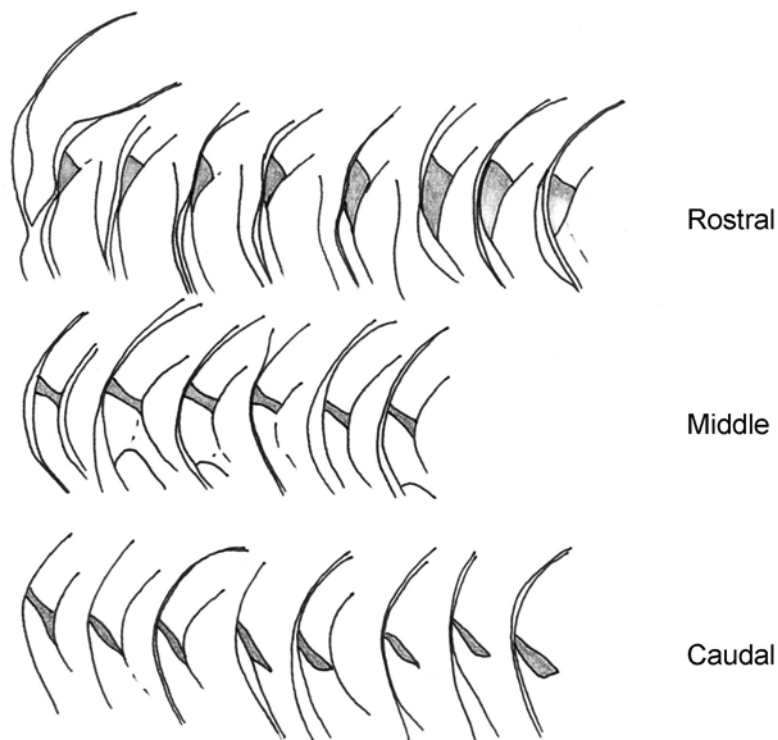

Figure 11. Different subdivisions of IGL (in gray): rostral, medial and caudal

limbic structures, like prefrontal cortex (Morin and Blanchard, 1999).

The major efference from the IGL reaches the SCN. This projection is named the **geniculohypothalamic tract (GHT)**. The fibers that compose this tract are characterized by GABA/NPY-ir (Moore and Card, 1994). These NPY fibers make synapses on the VIP neurons of the SCN (Hisano *et al.*, 1988; Francois-Bellan and Bosler, 1992). However, in the hamster, all CalB cells also have synaptic contacts with NPY-ir fibers from the GHT (LeSauter *et al.*, 2002). The IGL, by its projections via the GHT, provides therefore a **secondary indirect visual input** to the SCN.

III.1.1.3. The serotonergic tract

This SCN input (Fig. 9) will be described in the chapter “VI.1. The serotonergic system in the central nervous system”.

III.1.1.4. Other afferences of the SCN

SCN receives a lot of additional afferences that are less dense but could play a role in entrainment. For example, projections from the **thalamic paraventricular nucleus** innervate the vlSCN as well as the dmSCN. This structure is activated by different stimuli like stress (Chastrette *et al.*, 1991) or pain (Senba *et al.*, 1993).

SCN receives a lot of **hypothalamic projections**, e.g. from the subparaventricular zone, the dorsomedial nucleus, the lateral hypothalamic area, the paraventricular nucleus, the posterior paraventricular nucleus, the ventromedial nucleus and the arcuate nucleus (Moga and Moore, 1997). These projections, essentially to the dmSCN, are not very dense and their role is still unclear.

Since cholinceptors have been described in the SCN (van der Zee *et al.*, 1991), it is assumed that acetylcholine also exerts an influence on the SCN. Direct contacts between **cholinergic afferences** and SCN neurons have been revealed (Kiss and Halasz, 1996). This input seems to modulate the photic entrainment of the SCN (Erhardt *et al.*, 2004).

Two **limbic structures**, the lateral septum nucleus and the ventral subiculum as well as the **infralimbic cortex**, also project to the SCN. It has been proposed that the infralimbic cortex, receiving input from the olfactory areas, could play a role in the transmission of olfactory stimuli to the SCN.

III.1.2. Mechanisms of entrainment

Two types of environmental factors mediate daily entrainment of the SCN: **photic factors**, the most powerful, and **non-photic factors** that comprise all factors that are not photic. Moreover, the daily phase adjustment of the circadian clock implicates also multiple interactions between photic and non-photic cues.

III.1.2.1. Photic entrainment of the SCN

Physiological level

Light applied to an animal in constant conditions is able to **phase shift** rhythms, such as the locomotor activity rhythm in running wheel, plasma hormonal rhythms or global electrical

activity rhythm of SCN neurons. This phase shift can be a **phase advance** (the onset of activity rhythm will occur earlier the next days) or a **phase delay** (the onset of activity will occur later the next day). The amplitude and direction of these phase shifts depend on the circadian time. For example, in DD, a **light pulse (LP)** applied at the beginning of the subjective night (or active phase in nocturnal species) will induce a phase delay, whereas a LP applied at the end of the subjective night will induce a phase advance of the wheel-running activity rhythm the next day (Fig. 12). Furthermore, no phase shift of the locomotor activity rhythm will be observed after the application of a LP during most of the subjective day (or resting phase in nocturnal species). Thus, it is possible to draw up a graph representing the responses to light according to the CTs. This representation is named **phase response curve (PRC)** (Fig. 12). In natural conditions, animals are entrained to LD cycles, using these shifting effects. For example, if the endogenous period is shorter than 24 h, the locomotor activity rhythm will begin earlier every day and light, still present at the beginning of the active phase, will then induce a phase delay. But if the endogenous period is longer than 24 h, the

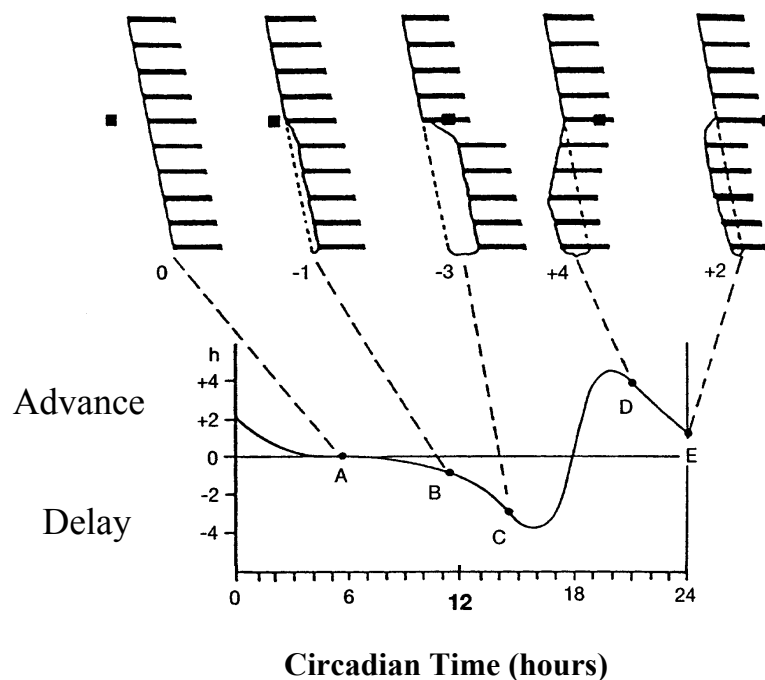

Figure 12. Phase response curve of the locomotor activity rhythm of a hamster. Light pulses (represented by black squares) induce phase advance or delay depending on the circadian time (modified from Servièrè and Laviaille, 1996a).

locomotor activity rhythm will be later every day and light, present at the end of the active phase, will then induce a phase advance.

Cellular level

Cellular mechanisms of photic stimulation are well studied (Fig. 13). Indeed, the stimulation of the retina by light, induces a subsequent release of neurotransmitters and neuropeptides from the RHT terminals in the vlSCN.

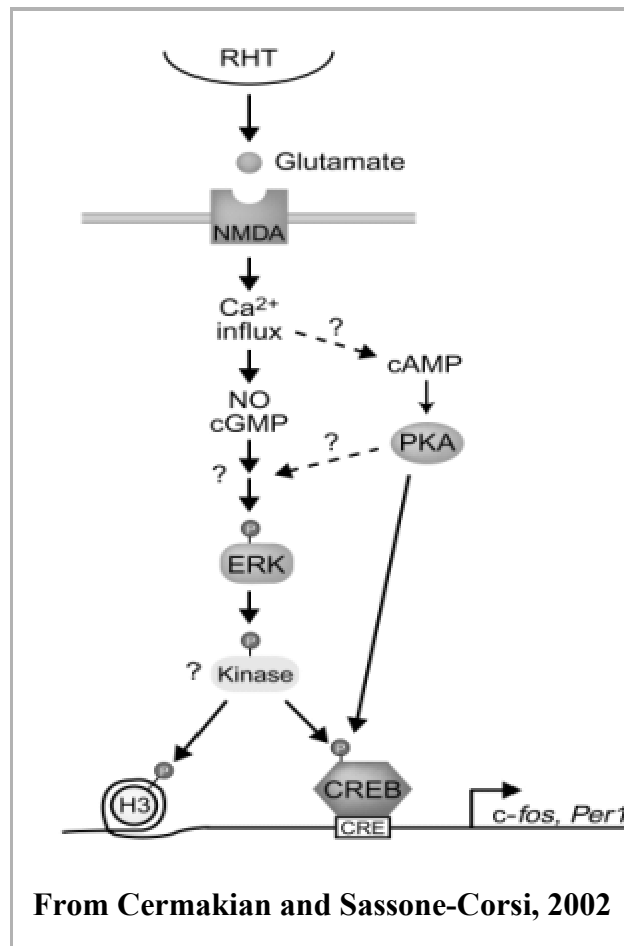

Figure 13. Cellular and molecular mechanisms of entrainment. RHT terminals release glutamate that link to the NMDA receptors. Subsequent cAMP and/or NO pathways are activated, leading to CREB phosphorylation and to c-fos and Per1 transcription.

Glutamate seems to act on the SCN neurons essentially through **N-methyl-D-aspartate (NMDA)** receptors (Colwell *et al.*, 1990). Treatment with MK-801, an antagonist of the NMDA receptors, before a light pulse, strongly decreased the effect of light on the SCN (Vuillez *et al.*, 1998). NMDA receptors activation resulted in a **calcium influx** in the SCN neurons (Tominaga *et al.*, 1994), leading to the synthesis of **Nitric Oxide (NO)** by the **NO Synthase (NOS)** (Ding *et al.*, 1994). After the synthesis of NO, two divergent mechanisms have been demonstrated, depending on the circadian phase. At the beginning of the night (when light induces phase delays), it seems likely that NO induces the activation of **ryanodine receptors** leading to the release of intracellular calcium (Ca^{2+}) (Ding *et al.*, 1998). At the end of the night (when light induces phase advances), the synthesis of NO induces the activation of another pathway, implicating **guanylate cyclase (GC)** and **cyclic guanosine monophosphate (cGMP)** (Ding *et al.*, 1994, 1998). Actually, cGMP can induce phase advances of wheel-running rhythms in hamsters (Prosser *et al.*, 1989). Moreover, light- or glutamate-induced phase advances, but not delays, were blocked by inhibition of cGMP-dependant protein kinase (Mathur *et al.*, 1996). Nevertheless, during the whole night, a light pulse resulted also in the activation of the **cyclic adenosine monophosphate (cAMP)** pathway, also involving the **protein kinase A (PKA)** or the pathway of the **guanylate triphosphatases (GTPases)** (member of the Ras family) (Takahashi *et al.*, 2003). These activations give rise to **cAMP response element binding protein (CREB)** phosphorylation through the activation of different kinases like **ERK (Extracellular signal-regulated protein kinases)**. CREB phosphorylation induces the expression of **immediate early genes (IEGs)**, in particular *c-fos*. IEGs belong to a gene family whose expression is briefly induced by a cellular stimulation. Indeed, CREB phosphorylation slightly precedes *c-fos* mRNA induction (Ginty *et al.*, 1993) through the binding of phospho-CREB to the *c-Fos* **CREB-responsive element (CRE)** (Sheng and Greenberg, 1990). *C-fos* induction in the SCN seems to be gated by the circadian clock, because a LP applied during the day had no effect on its expression (Aronin *et al.*, 1990) while a LP applied during subjective night will induce both behavioral phase shifts and *c-fos* expression in the SCN (Rusak *et al.*, 1990). Moreover, *c-fos* induction is phase dependent, meaning that *c-fos* expression is higher at the end of the subjective night and lower at its beginning (Kornhauser *et al.*, 1990). *C-fos* induction seems to be a prerequisite for phase shifting by light, since the intracerebral application of antisense oligonucleotides for *c-fos* and *junB* was shown to block light-induced phase shifts in the wheel-running rhythm of rats (Wollnik *et al.*, 1995). However, the increase of *c-fos* levels

per se does not necessarily lead to phase shifting (Colwell *et al.*, 1993; Edelman *et al.*, 2003). Moreover, KO mutant mice for *c-fos* were found to be rhythmic, can be entrained by the LD cycle and showed a PRC to light more or less similar to that of the wild-type (Honrado *et al.*, 1996). Besides *c-fos*, the expression of several other IEGs in the SCN, such as *jun-B*, appears to be induced by a light pulse. Different members of the fos and jun family form heterodimers, the so-called **AP-1** (Activator protein-1) **complexes**, transcription factors which enter the nucleus in order to activate the expression of other genes, named **late response genes** (Sheng *et al.*, 1990).

Moreover, **PACAP** and **SP**, which colocalize with glutamate in the RHT terminals, could play a modulatory role in entrainment (Hannibal *et al.*, 1997; Kim *et al.*, 2001). The PRC obtained after *in-vivo* injections of PACAP and SP, are similar to that obtained after LP stimulations (Piggins and Rusak, 1997; Piggins *et al.*, 2001). The PACAP receptor subtype involved seems to be the **PAC₁**. Its activation induced Ca²⁺ release from intracellular stores, through activation of **phospholipase C (PLC)** as well as of cAMP pathway (Kopp *et al.*, 1999).

The expression of *c-fos* protein and mRNA occurs mostly in VIP neurons after light stimulation (Daikoku *et al.*, 1992b). It has also been proposed that PHI and GRP play a prominent role during light-induced phase shifts. The PHI neurons seem to act during light-induced phase delay, while the GRP and VIP neurons seem to act during light-induced phase advance (Romijn *et al.*, 1996). Moreover, the contents of VIP and GRP did not show circadian rhythms in constant darkness, but under LD conditions, GRP content increased and VIP content decreased over the light period. These contents then gradually recovered during the dark period (Shinohara *et al.*, 1993). The application of VIP and Ro 25-1553, a VPAC₂ receptor (VIP/PACAP receptor 2) agonist on SCN neurons *in vitro* induced a PRC similar to light (Reed *et al.*, 2001). In addition, in KO mutant mice for VPAC₂, light failed to entrain the locomotor activity rhythm (Harmar *et al.*, 2002). Thus, VIP and the VPAC₂ receptor seem to have an important role in photic entrainment.

Recent discovery involves a cell adhesion molecule, **Polysialic Acid (PSA)- Neural Cell Adhesion Molecule (NCAM)** in the effects of light on the SCN. KO mutant mice for PSA-NCAM presented impairment in the locomotor activity rhythm (Shen *et al.*, 1997). Moreover, a strong polysialylation was observed after a light stimulation (Glass *et al.*, 2003) and pretreating SCN slices with endoneuraminidase which selectively removes PSA from

NCAM, abolished glutamate- and optic chiasm stimulation-induced phase delays of the SCN circadian neuronal activity rhythm (Prosser *et al.*, 2003).

Being another target of the retinal ganglion cells, the IGL could also play a role in photic entrainment. First, IGL is involved in entrainment of locomotor activity in response to 1 h LP given at dawn and dusk. Under this lighting schedule, named skeleton photoperiod, rats with IGL lesions were unable to be entrained and exhibited a locomotor rhythm that seems to free-run (Edelstein and Amir, 1999). Moreover in this structure, light pulses occurring during the subjective day as well as the subjective night elevated the level of *c-fos* mRNA and protein. Moreover, it has been shown that neurons with *c-fos* mRNA and c-Fos protein in the IGL project to the SCN (Peters *et al.*, 1996). In addition, IGL cells in the hamster displayed changes in the firing rate depending upon light intensity (Harrington and Rusak, 1991). In turn, IGL can convey this information to the SCN through the GHT. Indeed, a circadian variation has been reported for levels of NPY in the vlSCN under LD condition, with two peaks corresponding to the L-to-D and D-to-L transitions (Calza *et al.*, 1990). Under DD conditions, the NPY peak around CT 12 persisted, demonstrating its circadian control (see review: Inouye, 1996). These data have led to the hypothesis that NPY release from the GHT terminals conveys photic information during twilight times. Moreover, application of NPY antiserum to the SCN was able to enhance the phase advance in response to a light pulse at CT 18 (Biello, 1995). However, besides conveying photic information to the SCN, the IGL and GHT are also involved in conveying non-photoc information (see chapter: “III.1.2.2. Non-photoc entrainment of the SCN”).

Molecular level

Light pulses lead to the rapid expression of three different clock genes. These genes are *Per1* (Shigeyoshi *et al.*, 1997), *Per2* (Shearman *et al.*, 1997) and *Dec1* (Honma *et al.*, 2002). As the IEGs, those three clock genes are induced by light during subjective night. This induction is correlated to behavioral phase shifts, since injection of antisense phosphotioate oligonucleotide (ODN) *Per1* or *Per1/Per2* mRNA in the SCN inhibited the normal phase delay induced by light at CT 16 (Akiyama *et al.*, 1999). Antisense ODN *Per1* mRNA also blocked phase shifts induced by glutamate on SCN slices *in vitro* (Tischkau *et al.*, 2003). Moreover, there is a strong correlation between the amplitude of expression of *Per1* and *Per2* after NMDA receptors activation and phase shifts amplitude (Moriya *et al.*, 2000).

There are however differences between light induction of *Per1* and *Per2*. Induction of *Per1* seems to implicate the phosphorylation of CREB on serine 142. This is not the case for *Per2* expression. Indeed, *Per2* expression induced by light was not disturbed by the loss of CREB phosphorylation on serine 142 (Gau *et al.*, 2002). In addition, the sensibility phases to light of these two clock genes are different:

- ***Per1*** is induced by a LP at the **beginning** as well as the **end of the subjective night**. However, contrary to *c-fos*, there is no difference in expression level depending on the CT of the stimulation during the night (Shigeyoshi *et al.*, 1997; Honma *et al.*, 2002).
- ***Per2*** is induced **only** when light occurs at the **beginning of the subjective night** (Albrecht *et al.*, 1997), and seems to be implicated only in the phase delays induced by light.

This was confirmed by a study with KO mutant mice for *Per1* and for *Per2*. KO mutant mice for *Per1* only showed disturbance of the light-induced phase advance whereas KO mutant mice for *Per2* only showed disturbance of the light-induced phase delay (Albrecht *et al.*, 2001).

Moreover, the region of the SCN as well as the phenotype of the cells that expressed *Per1* and/or *Per2* after a LP are different (Dardente *et al.*, 2002). *Per1* induction was clearly restricted to the vlSCN and seems to be localized in the GRP neurons of the SCN. *Per2* expression is much broader, occurring also in VP cells. The apparent differential regulation of these two clock genes suggests that they have distinct regulatory elements and that they serve different functions within the SCN.

As mentioned before, *Dec1* is another clock gene induced by light during the night. The temporal pattern of photic induction is similar to that of *Per1*, albeit with a lower amplitude.

BMAL1 could also play a role in the light-induced phase shifting effects. BMAL1 was quickly degraded after a light pulse or after an application of glutamate on SCN slices *in vitro* (Tamaru *et al.*, 2000). This degradation was phase dependent: absent at CT 6, when *Per1* and *Per2* are not induced by light, and high at CT 15 and CT 21, when *Per1/Per2* and *Per1*, respectively, are strongly induced by light exposure. These results however, were not confirmed by von Gall *et al.*, 2003.

Cry2 expression seems also to be sensitive to photic stimuli. Okamura *et al.* (1999) noticed that light can decrease the levels of *Cry2* in the SCN of mice exposed to light at the end of the subjective night.

The light-induced expression of clock genes in the SCN is not homogenous. In the early night, a LP leads to increased levels of *Per1* mRNA (Yan *et al.*, 1999) and proteins (Hastings *et al.*, 1999) in the vlSCN and more precisely in the VIP and GRP neurons in the rat (Dardente *et al.*, 2002). At this time, light-induced expression of *Per2* was widely distributed in the SCN, in VIP/GRP cells as well as in VP cells (Dardente *et al.*, 2002). In the late night, a LP did not activate *Per2* expression, but produced an increase of *Per1* mRNA levels in both ventrolateral and dorsomedial parts of the SCN of mice (Yan and Silver, 2002).

III.1.2.2. Non-photic entrainment of the SCN

The effects of non-photic factors on circadian rhythms are different from those induced by photic factors. They generally entrain the master clock during the **subjective day** and induce **phase advances** of circadian rhythms (Fig 14). The non-photic factors comprise a lot of different stimuli, like behavioral arousal, restricted feeding or treatment with chronobiotic drugs.

Physiological level

Behavioral cues

Arousal or induced physical activity is the most studied non-photic factor. An increase of the activity level of a nocturnal animal during its inactive period results in large phase advances, while small phase delays are obtained after behavioral activation in late subjective night. A common procedure is to place a hamster in a novel clean wheel (Wickland and Turek, 1991). This usually makes the animal run (i.e., so-called **novelty-induced activity**) and the SCN clock is phase shifted. Amplitude of the phase advance of the circadian rhythm induced by this non-photic factor is correlated to the level of locomotor activity (Reebs and Mrosovsky, 1989). Forced treadmill running and confinement to running wheel during the resting period also produced phase advances in mice, but of lower amplitude than those observed in Syrian hamsters (Marchant and Mistlberger, 1996). Besides novelty-induced wheel running, other stimuli that induce transient hyperactivity and arousal during the usual resting period can also produce phase advances. These factors include **triazolam and benzodiazepine injection in Syrian hamster** (Van Reeth and Turek, 1989;

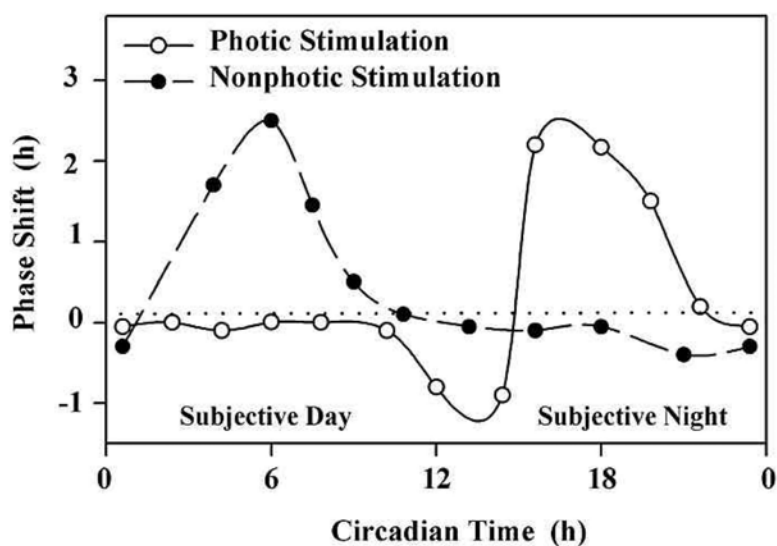

Figure 14. Photic and non-photic PRCs of a Syrian hamster (From Challet and Pévet, 2003).

Cutrerera *et al.*, 1994a) and **morphine injection in mice** (Marchant and Mistlberger, 1995). However, other studies showed that **sleep deprivation** is also able to induce phase advance of the locomotor activity rhythm, thus suggesting that arousal seems more relevant than activity to explain the mechanisms of action of these non-photic factors (Antle and Mistlberger, 2000).

Metabolic cues

Restricted feeding is able to affect the circadian timing system. It is however necessary to distinguish between **temporally restricted feeding** (i.e., supplying food for a limited daily period) and **timed caloric restriction** (i.e., when only a hypocaloric diet is given each day at the same time). Schedules of temporally restricted feeding in animals maintained in DD usually only synchronize a bout of locomotor activity anticipating the time of feeding (named “**food-anticipatory activity**”), while the other circadian components of locomotor activity continue to free-run (Mistlberger, 1994). The food-anticipatory activity is considered to be driven by a **food-entrainable clock** outside the SCN because it occurs in food-restricted animals with SCN lesions. In contrast, a timed caloric restriction applied in DD is a potent Zeitgeber for the SCN clock, given that it entrains circadian rhythms of locomotor activity and body temperature in rats kept in DD (Challet *et al.*, 1996a). Furthermore, **prolonged fasting** (i.e., no food available during several days) in free-running rats induced phase shifts

of circadian rhythms of locomotor activity and body temperature, indicating that metabolic cues can, directly or indirectly, impact on SCN function (Challet *et al.*, 1997a).

Other cues

Melatonin administration at the end of the subjective day can be considered as a non-photoc factor since it can entrain circadian rhythms of nocturnal (Armstrong and Redman, 1985; Pitrosky *et al.*, 1999) and diurnal rodents (Slotten *et al.*, 2002). This effect is independent of a transient increase of locomotor activity.

Cellular level

The **geniculohypothalamic NPYergic pathway** seems to be implicated in the mediation of non-photoc cues to the SCN, demonstrated by IGL lesion, IGL electrical stimulation as well as IGL neurotransmitters agonist or antagonist injections. **Lesions of the IGL** impaired phase shifts resulting from novelty-induced wheel running in hamsters (Janik and Mrosovsky, 1994), forced running on treadmills in mice (Marchant *et al.*, 1997), triazolam injections (Schuhler *et al.*, 1999) and injections of chlordiazepoxide, a benzodiazepine, in Syrian hamsters (Maywood *et al.*, 1997). Furthermore, pretreatment with NPY antiserum markedly attenuated phase advances induced by novelty-induced wheel running in hamsters (Biello *et al.*, 1994). **Electrical stimulation of the GHT** in hamsters placed in DD, induced phase shifts similar to those of non-photoc cues (Rusak *et al.*, 1989). **Microinjections of NPY into the SCN region** induced behavioral phase shifts similar to a non-photoc PRC (Huhman and Albers, 1994), indicating that NPY seems to convey non-photoc information to the SCN. The same pattern of phase shifting responses on neuronal electrical activity has been obtained in isolated SCN slices *in vitro* after NPY administration (Shibata and Moore, 1993).

There are few studies about the role of ENK in the transmission of non-photoc information from the IGL. Nevertheless, opioids receptors have been described in the SCN and injection of an ENKergic agonist in the SCN of hamsters induce non-photoc phase shifts (Byku and Gannon, 2000).

Another important pathway implicated in the non-photoc entrainment is the serotonergic input to the SCN. This issue will be addressed in chapter: “IV. The serotonergic system”.

The afferent pathway coming from the **ventromedial hypothalamic nuclei (VMH)** to the SCN (Canteras *et al.*, 1994) has been also involved in mediating the effects of timed caloric restriction. Such a role has been demonstrated by using chemical lesions of the VMH in calorie-restricted rats (Challet *et al.*, 1997b) and mice (Challet *et al.*, 1998b). Some of the VMH inputs to the SCN are thought to release excitatory amino acids (Moga and Moore, 1996). In addition to direct projections to the SCN, indirect pathways from the VMH to the relay structures could also participate in the metabolic modulation of SCN function. These areas that receive projections from the VMH include the IGL (Vrang and Mikkelsen, 1996), a key structure in non-photic phase shifting as noted above.

The **paraventricular thalamic nuclei (PVT)** are another candidate structure in non-photic phase shifting. Indeed, the PVT send direct fibers releasing excitatory amino acids to the SCN (Moga and Moore, 1996).

Another structure that has been shown to mediate non-photic cues to the SCN is the **pretectum** projecting to both the SCN (Mikkelsen and Vrang, 1994) and the IGL (Marchant and Morin, 1999). Electrolytic pretectal or tectal lesions impaired the phase shifting properties of triazolam, but not those of novelty-induced running (Marchant and Morin, 1999).

Molecular level

Despite the fact that non-photic cues have no effect on the expression of IEGs, they **decrease the amplitude of *Per1* and *Per2* expression**, when applied during the subjective day. These effects of non-photic signals on clock gene expression include *in vivo* paradigms such as novelty-induced running in hamsters (Maywood *et al.*, 1999), intracerebroventricular injections of NPY in mice (Maywood *et al.*, 2002), as well as *in vitro* analysis of the effects of NPY treatment on SCN slices (Fukuhara *et al.*, 2001) or of previous *in vivo* novelty-induced running (Yannielli *et al.*, 2002).

In contrast to non-photic cues associated with increased locomotor activity, a **melatonin injection** during the late subjective day inducing a subsequent phase advance of the circadian clock did not lead to acute changes in *Per1* and *Per2* gene expression within the SCN (Poirel *et al.*, 2003). However, it induced an **increase of the expression of *Rev-erba*** in the SCN (Agez *et al.*, unpublished data).

In mice housed in DD, **restricted feeding did not change the phase of cyclic clock gene expression in the SCN** (Damiola *et al.*, 2000), indicating that restricted feeding does

not have strong synchronizing properties for the master circadian clock. In contrast to schedules of restricted feeding, a **timed caloric restriction** applied in DD was a potent Zeitgeber for the SCN clock, given that oscillations of **clock genes** in the SCN of caloric-restricted animals were **in phase with the time of feeding** (Caldelas *et al.*, in press).

III.1.2.3. Interactions between photic and non-photoc cues

Light exposure during the day can modify the processing of non-photoc signals by the SCN clock. Conversely, several non-photoc factors have been found to modulate, to some degree, circadian responses to LP during the night and/or the phase angle of entrainment to the LD cycle, i.e. the phase difference between the light on and the beginning of the activity (see review, Challet and Pévet, 2003).

Physiological level

Double-pulse experiments have been conducted in DD by firstly applying a non-photoc stimulus, either confinement to a novel wheel or triazolam injection, during the mid-subjective day followed by a photic stimulus (Mrosovsky, 1991; Joy and Turek, 1992). Both studies revealed that the **synchronizing effects of non-photoc factors could be altered by subsequent exposure to light**. Conversely, **exposure to non-photoc cues**, like nocturnal wheel running activity in hamsters (Ralph and Mrosovsky, 1992) or nighttime injection of morphine in mice (Mistlberger and Holmes, 1999) during or before nocturnal exposure to light, **modulated light-induced phase advances**. However, both treatments did not significantly modify light-induced phase delays (Mistlberger and Antle, 1998; Mistlberger and Holmes, 1999). Moreover, daytime sleep deprivation has been shown to attenuate light-induced phase delays in both hamsters (Mistlberger *et al.*, 1997) and mice (Challet *et al.*, 2001). In addition, a decrease in glucose availability can reduce photic phase resetting in mice (Challet *et al.*, 1999).

Other studies have strengthened the potential importance of non-photoc effects in **influencing the steady-state phase of photic entrainment**. In hamsters entrained to a LD cycle, a single 3 h confinement to a new wheel during the mid-day was able to phase advance transiently the phase angle of photic entrainment by 30 min (Janik *et al.*, 1994). In rodents, another non-photoc procedure, namely a schedule of restricted feeding, has been shown to

slightly affect the phase angle of photic entrainment (Mistlberger, 1991). However, the acrophase of VP release was not phase shifted by restricted feeding schedules in rats kept under a LD cycle (Kalsbeek *et al.*, 1998). A more marked alteration in the phase angle of photic entrainment was observed when rodents (excluding Syrian hamsters) were subjected to a daytime restricted feeding coupled with calorie restriction (Challet *et al.*, 1997c).

Cellular level

The interaction between photic and non-photoc cues can occur during the night and during the day.

Timed caloric restriction decreases the light-induced c-Fos expression occurring during the night (Challet *et al.*, 1997d), providing an argument for an inhibitory modulation of non-photoc stimuli on light effects. Moreover, **NPY** seems to play a role in the reduction of the effect of light on the circadian system. Indeed, light-induced phase advances in hamsters were inhibited by microinjections of NPY in the SCN region (Weber and Rea, 1997) and enhanced by treatment with NPY antiserum (Biello, 1995). In the same way, NPY application on SCN slices *in vitro*, prevented both phase advances and delays induced by glutamate administration (Biello *et al.*, 1997).

During the day, the phase advancing effects of NPY infusion in the SCN region of hamsters (Biello and Mrosovsky, 1995) and mice (Maywood *et al.*, 2002) were markedly reduced by a subsequent LP. Moreover, combined applications of different neurotransmitters have revealed numerous neurochemical interactions within SCN slices maintained *in vitro*. Actually, application of glutamate on SCN slices, blocked SCN phase shifts to NPY (Biello *et al.*, 1997). In addition, while treatment with PACAP phase advanced the SCN clock, co-application of NPY blocked this effect (Harrington and Hoque, 1997).

However, 5-HT seems also to be an important component of the interaction between photic and non-photoc factors, but will be detailed in chapter: “IV. The serotonergic system”.

Molecular level

Because non-photoc cues reduce the phase shifting effect of light during the night, one could expect that non-photoc cues could also **reduce the light-induced expression of *Per* genes**. Indeed, injection of a benzodiazepine, brotizolam, given before a LP at the end of the

subjective night reduced light-induced expression of *Per1* and *Per2* in hamsters (Yokota *et al.*, 2000). Moreover, the light-induced increase of *Per1* and *Per2* mRNA in the SCN during the night was attenuated by subsequent application of NPY *in vitro* (Brewer *et al.*, 2002).

Other studies have recently investigated the combined effects of light and novelty-induced running (Maywood and Mrosovsky, 2001) as well as light and NPY (Maywood *et al.*, 2002) on the expression of *Per1* and *Per2* during the daytime. Both studies showed that subsequent light attenuates the non-photoc reduction in *Per* expression.

Consistent with the fact that schedule of restricted feeding applied under a LD cycle do not entrain circadian rhythms, they also do not affect the expression of clock genes in the SCN (Damiola *et al.*, 2000).

5-HT seems also to be implicated in the molecular mechanisms of interaction between photic and non-photoc cues, but this issue will be detailed in chapter: “IV. The serotonergic system”.

Photic information mainly conveyed by the RHT and its neurotransmitters is the most powerfull Zeitgeber of the SCN. The non-photoc cues and their mechanisms of entrainment are more diverse and complex. Actually, each non-photoc factor acts through several cellular and molecular mechanisms. Moreover, in natural environment, daily entrainment involves both photic and non-photoc Zeitgebers, that interact and modulate the effects of each other.

III.2. The distribution of the circadian message

The circadian rhythm generated in the SCN is imposed on many physiological functions, including locomotor activity, body temperature, sleep, water and food intake, but also hormonal secretion, like melatonin or corticosterone, as well as neuropeptide release or receptor density. The SCN seems to use at least two types of pathways in order to distribute the rhythmic message to the brain: **neuronal pathways** and a **pathway involving a diffusible signal**. Moreover, the SCN drives the **rhythmicity of other brain regions and peripheral organs** apparently through endocrine pathways, like melatonin or corticosterone.

III.2.1. Neuronal pathways

The SCN neurons innervate a few brain structures, mainly hypothalamic structures. Those pathways are, among others, involved in the control of neuroendocrine and autonomic functions. The great majority of efferent SCN fibers remain confined within the boundaries of the medial hypothalamus, reaching the **medial preoptic area**, the **paraventricular nucleus of the hypothalamus (PVN)**, the **subparaventricular zone (sPVz)** and the **dorsomedial nucleus of the hypothalamus (DMH)**. Outside the hypothalamus, the SCN projects to the **paraventricular nucleus of the thalamus** and the **IGL** (Watts and Swanson, 1987; Watts *et al.*, 1987; Fig. 15). For the input pathways, as for the output pathways, a segregation is seen between the vlSCN and the dmSCN. The vlSCN appears to project to the lateral sPVN, while the dmSCN projects to the medial sPVN and the DMH (Leak *et al.*, 1999).

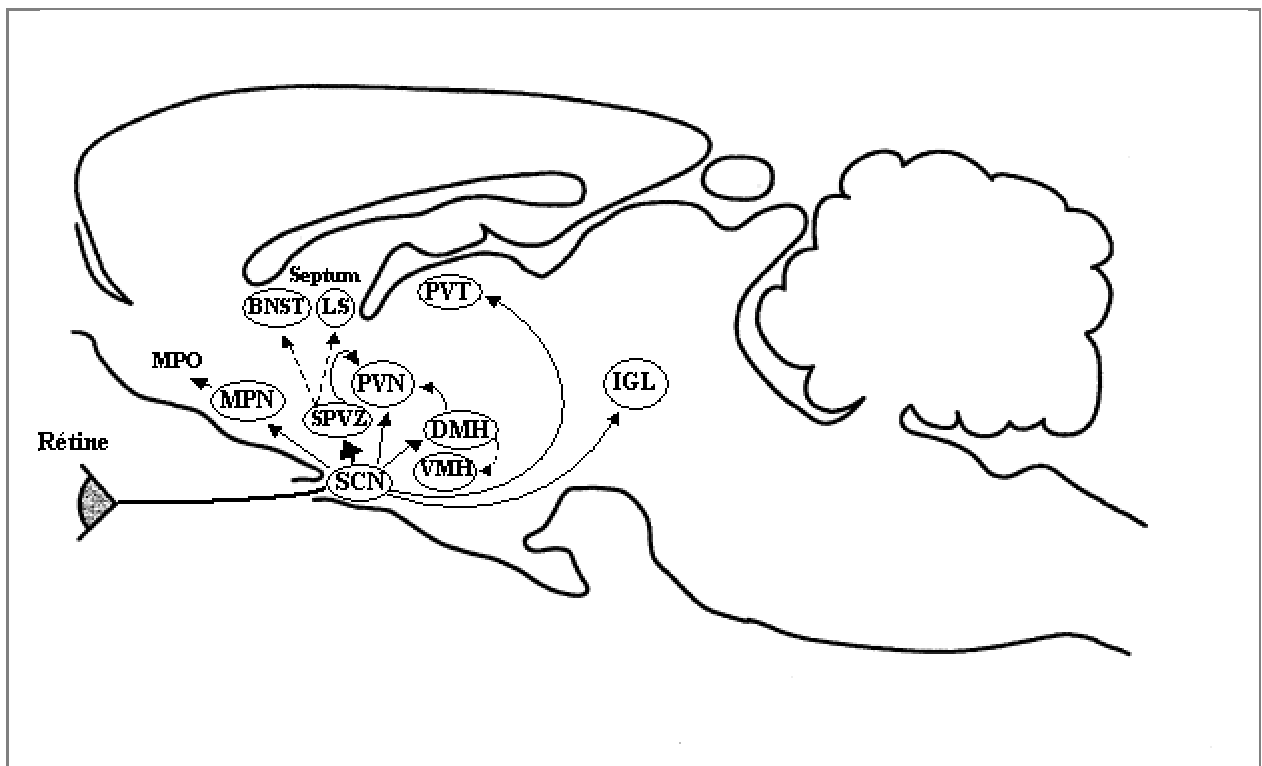

Figure 15. Major SCN efferences (modified from Buijs, 1996)

BNST: Bed nucleus of the stria terminalis, DMH: Dorsomedial nucleus of the hypothalamus, IGL: Intergeniculate leaflet, LS: Lateral septum, MPN: Medial preoptic nucleus, MPO: Medial preoptic area, PVN: Paraventricular nucleus of the hypothalamus, PVT: Paraventricular nucleus of the thalamus, sPVz: Subparaventricular zone, VMH: Ventromedial nucleus of the hypothalamus

Functional studies have to some extent confirmed a role of VP in signalling circadian rhythm to the SCN target areas via its efferent projections. Elimination of the VPergic neurons reached by intracerebroventricular application of a specific immunotoxin, for instance, resulted in the disappearance of circadian drinking rhythmicity in the rat (Shimizu *et al.*, 1996). Moreover, several studies reported a correlation between the number of VPergic neurons in the SCN and the strength and consistency of circadian activity rhythms. In different rat strains and mice selected for differences in nest-building behavior, the animals with the highest number of VPergic neurons in the SCN had the strongest unimodal activity pattern, whereas the animals with the lowest number of VPergic neurons had the weakest multimodal activity pattern (Bult *et al.*, 1993; Wollnik and Bihler, 1996). However, Brattleboro rats deficient in VP (Guitteny *et al.*, 1989; Kim *et al.*, 1997) do not show perturbations of the drinking rhythm (Groblewski *et al.*, 1981) raising the question of the VP function. It seems more likely that VP has a modulatory role on the SCN electrical activity (Ingram *et al.*, 1996), by amplifying this rhythm. However, VP seems strongly involved in the control of corticosterone release and plasma melatonin levels. Infusion of VP in the PVN and DMH suppressed elevated levels of corticosterone in SCN-lesioned animals to reach basal daytime values. Moreover, infusion of a VP antagonist in the same hypothalamic area induced an increase of basal corticosterone levels in intact animals (Kalsbeek *et al.*, 1992). In addition, infusions of VP increased plasma melatonin levels (Kalsbeek *et al.*, 1993).

Projections from the SCN to the PVN are of great importance, since the PVN coordinates neuroendocrine and autonomic mechanisms by a complex series of neural connections to and from various hypothalamic regions (Swanson and Sawchenko, 1980). This projection is notably the first step of control pathways for melatonin and corticosterone.

The best described of these is a **multisynaptic pathway by which the SCN controls the nocturnal synthesis and secretion of the pineal hormone melatonin**. This multisynaptic pathway consists of a **GABAergic and glutamatergic** projection from the SCN to the PVN (Hermes *et al.*, 1996; Kalsbeek *et al.*, 1999; Perreau-Lenz *et al.*, 2004), then projections from the PVN to the intermediolateral column of the spinal cord, and further connections to the pineal gland via the superior cervical ganglion.

The second best described pathways are the **pathways controlling corticosterone plasma rhythms** (Buijs *et al.*, 1998). One route of control is a direct synaptic contact of SCN neurons on the corticotroph releasing factor-producing neurons of the PVN. This factor may

control the rhythmic release of adrenocorticotrophic hormone from the anterior lobe of the pituitary, that in turn leads to the rhythmic production and release of corticosterone from the adrenal gland. Another route of control is a multisynaptic pathway via the PVN and the intermediolateral column neurons of the spinal cord to the adrenal (Buijs *et al.*, 1999).

III.2.2. Distribution of the rhythmic message by a diffusible signal

The second pathway involved a diffusible signal that is rhythmically released by the SCN and that seems to control the locomotor activity rhythm (for review see LeSauter and Silver, 1998).

III.2.2.1. Experimental evidences

Two experimental proofs provide strong arguments toward an implication of a diffusible signal in the control of the locomotor activity rhythm: **insulation of the SCN** from the rest of the brain and **SCN graft transplantation**.

SCN insulation never induced a total loss of locomotor activity rhythm and showed that the different physiological rhythms are controlled by distinct efferences (Hakim *et al.*, 1991).

But the demonstration of a diffusible factor was given by SCN grafts transplantation in SCN lesioned animals. Indeed, in rats, the circadian rhythm of wheel-running activity was restored by the graft (Sawaki *et al.*, 1984). Moreover, rhythm restoration has also been shown when transplants are located in the lateral ventricle or in the foramen of Monro, sites from which appropriate neural connections with targets in the thalamus and hypothalamus are unlikely (Aguilar-Roblero *et al.*, 1992, 1994). Finally, SCN transplants that were encapsulated in a semi-permeable polymer capsule which prevents neural connections with the host brain, were still able to restore circadian locomotor rhythms in the SCN lesioned hamsters (Silver *et al.*, 1996b). However, this rhythm restoration was specific for the locomotor activity. Actually, a SCN graft was not able to restore photoperiodic responses of reproduction (Lehman *et al.*, 1987), oestrus cycle and LH, melatonin or corticosterone secretion rhythm (Meyer-Bernstein *et al.*, 1999).

In conclusion, a diffusible signal seems to be involved in the control of the locomotor activity rhythm. However, this signal is not sufficient to control other physiological rhythms

like neuroendocrine rhythms that are more likely entrained by the SCN via its neuronal projections.

III.2.2.2. Candidates for diffusible signals

Transforming growth factor (TGF α) and the **prokineticine 2 (PK2)** that are synthesized in the SCN, are two good candidates.

TGF α shows a circadian synthesis, with acrophase during the subjective day (Kramer *et al.*, 2001). TGF α seems to inhibit wheel-running activity since a TGF α injection in the third ventricle blocked the wheel-running activity of the animals which started to run again in the wheel after the end of the injection. The epidermal growth factor receptor (EGFR) that is strongly expressed in the sPVz, is one of its receptors.

PK2 has also a circadian synthesis in the SCN with high levels during the subjective day (Cheng *et al.*, 2002). Moreover, the dimer CLOCK-BMAL1 as well as phosphorylated CREB can link onto its promoter and subsequently induce its transcription. PK2 expression can therefore be induced by light. PK2 receptor (PK2R) synthesis is restricted to efferent structures of the SCN (PVN, PVT,...). Finally, PK2 intracerebroventricular injection during the night decreases the level of locomotor activity.

III.2.3. Rhythmicity outside the SCN

Besides the SCN clock, there are circadian oscillators in other brain regions and peripheral organs. Many nervous or peripheral tissues and isolated cells express clock genes (for review: Balsalobre, 2002; Schibler and Sassone-Corsi, 2002; Fukuhara and Tosini, 2003), for example heart (Young *et al.*, 2001) or vascular smooth muscle cells (Nonaka *et al.*, 2001). Moreover, retina is capable of maintaining self-sustained oscillations *in vitro* (Tosini and Menaker, 1996). The construction of a transgenic rat line in which luciferase was rhythmically expressed under the control of the mouse clock genes promoter gave a powerful technic to follow rhythms in peripheral organs (Yamazaki *et al.*, 2000). Depending on the clock gene promoter controlling luciferase expression, the rhythm was self-sustained (*Per2* promoter) or not (*Per1* promoter). Recent studies showed that, using two reporter systems with *Per2* promoter, *in vitro* cultured fibroblasts harbour self-sustained and cell-autonomous

circadian clocks similar to those operative in SCN neurons (Nagoshi *et al.*, 2004), but the lack of oscillator coupling in dissociated cell cultures leads to a loss of synchrony among individual cells and results in the damping of the whole rhythm at the population level (Welsh *et al.*, 2004).

There are however differences between the oscillations of clock genes in the SCN and those seen in extra-SCN and peripheral cells. For example, daily expression of *Clock* may cycle in the liver (Lee *et al.*, 2001) while it seems to remain constant throughout the day in the SCN (Shearman *et al.*, 2000b). NPAS2 (also known as MOP4) is a bHLH-PAS transcription factor sharing high homology with CLOCK (Reick *et al.*, 2001). In contrast to *Clock*, *Npas2* is not expressed at detectable levels in the SCN (Shearman *et al.*, 1999), but is present in several regions of the forebrain, such as cerebral cortex and hippocampus (Reick *et al.*, 2001). NPAS2 can dimerize with BMAL1 to activate rhythmic transcription of *Per* and *Cry* and thus NPAS2 could be a specific component of the forebrain oscillators (Reick *et al.*, 2001). The timing for clock gene oscillations in the peripheral oscillators appears to be similar to that of SCN, but with a 6-8 h delay (Damiola *et al.*, 2000). Peripheral oscillators can be entrained as the SCN. However the mechanisms are different. Daytime food restriction in nocturnal rodents has been demonstrated to be a strong Zeitgeber of the molecular clockwork in peripheral oscillators like liver, heart, kidney and pancreas, not only in constant darkness, but also under a LD cycle (Damiola *et al.*, 2000). The gradual phase changes in circadian gene expression in liver have been shown to be faster than in other organs (Damiola *et al.*, 2000). Moreover, phase advances of molecular oscillations within the liver in response to daytime restricted feeding still occur in SCN-lesioned mice (Hara *et al.*, 2001). In this condition of temporal restricted feeding, peripheral oscillators become uncoupled from the master SCN clock.

Besides reduced food availability, other signals have been proposed to mediate synchronization of peripheral organs, such as glucocorticoid hormones (Balsalobre, 2002) and temperature (Brown *et al.*, 2002).

In conclusion, peripheral cells seem to have the same ability of producing self-sustained oscillations as SCN cells. However, peripheral oscillators are not able to remain synchronized in a tissue in absence of SCN involvement. In addition, there are some differences for clock gene expression and entrainment mechanisms between two cells types: peripheral cells and SCN neurons.

IV. The serotonergic system

Serotonin (or 5-hydroxytryptamine: 5-HT) was discovered in blood in the 19th century (Rapport *et al.*, 1948). This substance was first known to induce vessel constriction. A few years later, it was found to be a neurotransmitter of the central nervous system (Twarog and Page, 1953). 5-HT is involved in many functions, like sleep, pain and thermoregulation, but it is also known to have a role in many psychiatric disorders, such as anxiety or depression. It has been related to Alzheimer disease too.

IV.1. The serotonergic system in the central nervous system

IV.1.1. Anatomical data

IV.1.1.1. Serotonergic nuclei

Serotonin-containing neurons are restricted to different nuclei extending **from the spinal cord to the brain stem** (Fig. 16) and can be divided into **inferior and superior groups** (for review, Jacobs and Azmitia, 1992). The classical nomenclature assigns a number from B₁ to B₉ to all 5-HT nuclei (Table 2).

- The inferior group is composed of raphe pallidus (B₁ and B₄), obscurus (B₂) and magnus (B₃) nuclei.
- The superior group is composed of raphe pontis (B₅), median (**MRN** or B₅ and B₈), dorsal (**DRN** or B₆ and B₇), linearis (B₈) and lateral (B₉) nuclei.

The DRN contains the highest percentage (40%) of 5-HT neurons compared to other raphe nuclei. This nucleus can be divided in four regions: dorsomedian, ventromedian and two lateral regions.

IV.1.1.2. Afferences

Some of the afferences come from nuclei in the **brain stem** such as the superior vestibular nucleus, the perihypoglossal nucleus, the nucleus of the solitary tract, the locus coeruleus, the substantia nigra, the ventral tegmental area or the periaqueducal gray substance

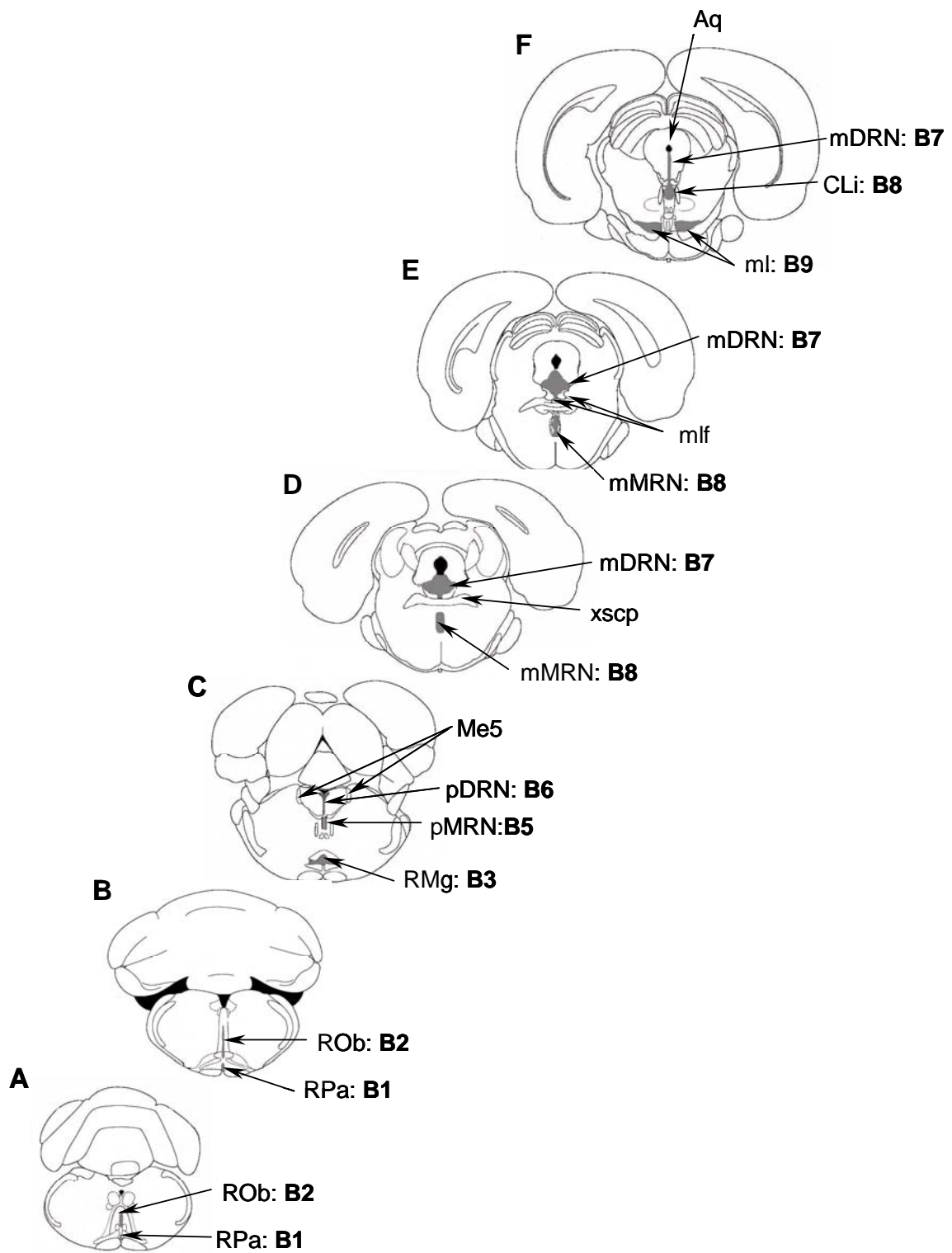

Figure 16. Representation of the different raphe nuclei (gray areas) on serial frontal slides of the brain stem from the caudal to the rostral part. A, B, C, D, E, F, correspond to interaural slides -4.68mm, -2.8mm, +1mm, +1.36mm and +1.96mm, respectively (modified from Paxinos and Watson atlas, 1986). Abbreviations: Aq: Sylvius aqueduct; CLi: Caudal linear nucleus; DRN: Dorsal raphe nucleus; Me5: Mesencephalic trigeminal nucleus; ml: Medial lemniscus; mlf: Medial longitudinal fasciculus; MRN: Medial raphe nucleus; PRN: Pontine raphe nucleus; RMg: Raphe magnus nucleus; ROb: Raphe obscurus nucleus; RPa: Raphe pallidus nucleus; xscp: Decussation of the superior cerebellar peduncle.

Alphanumeric classification	Cytoarchitectural regions
B₁	Raphe pallidus nucleus (RPa)
B₂	Raphe obscurus nucleus (ROb)
B₃	Raphe magnus nucleus (RMg)
B₄	Central gray of the medulla oblongata
B₅	Pontine median raphe nucleus (pMRN)
B₆	Pontine dorsal raphe nucleus (pDRN)
B₇	Midbrain dorsal raphe nucleus (mDRN)
B₈	Midbrain median raphe nucleus (mMRN) Caudal linear nucleus (CLi)
B₉	Medial lemniscus (ml)

From Halliday *et al.*, 1995

Table 2. The nomenclature assigned to 5-HT neurons

(Kalen *et al.*, 1985). Other structures sending afferences include **hypothalamus** (preoptic and lateral hypothalamic areas; Sakai *et al.*, 1977), **thalamus** and **limbic forebrain system** (lateral habenula and prefrontal cortex). Moreover, at least in rats, the DRN receive a little tract originating in the retina (Shen and Semba, 1994). An important afferent input to the raphe nuclei consists of connections between the DRN and the MRN, B₁, B₉ and B₃ (Mosko *et al.*, 1977).

IV.1.1.3. Efferences

The majority of the raphe nuclei located caudally in the brain project to the spinal cord, while raphe nuclei located more rostrally project to the forebrain. Those efferences are named descending and ascending projections, respectively.

Descending projections

These projections are organized in two pathways (for review see Jacobs and Azmitia, 1992). The first pathway, named **bulbospinal pathway**, originates in the nuclei B₁ to B₄ and innervates the spinal cord. This pathway seems to be notably implicated in the modulation of nociceptive information (Ruda *et al.*, 1982). The second pathway originates in the DRN and innervates the locus coeruleus.

Ascending projections

Fibers originating essentially in the DRN and the MRN, first form **three bundles** (Parent *et al.*, 1981): the dorsal, the medial and the ventral ascendant bundle. They merge later to constitute the **medial forebrain bundle**. The majority of the 5-HT fibers present in this bundle are **not myelinated** (Azmitia and Gannon, 1983). Serotonergic fibers seem to innervate most of the brain regions since 5-HT can be found in all regions. However, each brain region is specifically and more or less densely innervated. The main regions that receive 5-HT fibres are: the olfactory bulb, the septal region, the hippocampus, the neostriatum, the amygdala, the cerebral cortex, the thalamus (and more precisely the IGL) and the hypothalamus (Azmitia and Segal, 1978). In this structure, the SCN, and more precisely the VIP neurons, are densely innervated (Bosler and Beaudet, 1958 ; Fig. 17). The DRN and

MRN innervate differentially the forebrain structures. For example, in the hamster, the IGL is only innervated by the DRN whereas the SCN is innervated by the MRN (Meyer-Bernstein and Morin, 1996).

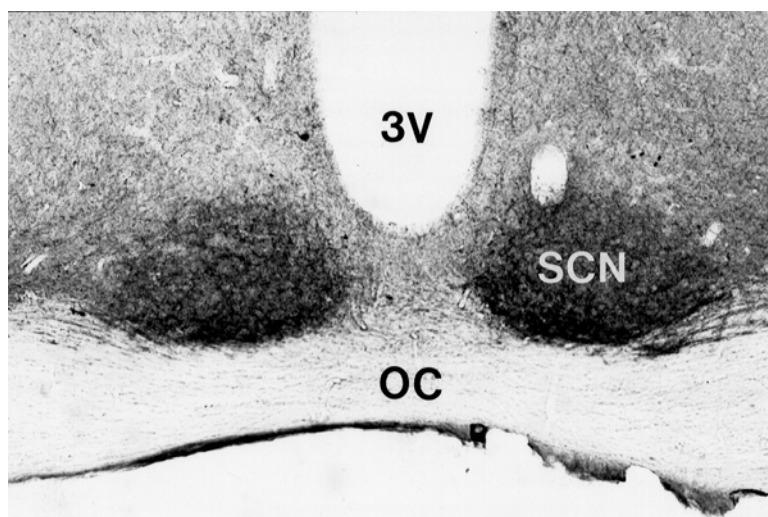

Figure 17. Serotonergic immunoreactivity in the SCN. OC: optic chiasma; 3V: third ventricle.

IV.1.2. Serotonergic neuron functioning

IV.1.2.1. Serotonin metabolism

Figure 18 summarizes the important steps of 5-HT metabolism. For review see Boadle-Biber in 1993.

Synthesis

The precursor of 5-HT is the **tryptophan (TRY)**. Within the cytosol of serotonergic neurons, TRY is converted to 5-HT by a two-step enzymatic reaction. The first implicated enzyme, the **tryptophan hydroxylase (TpOH)**, transforms TRY to **5-hydroxytryptophan (5-HTP)** (Ashcroft *et al.*, 1965). The intermediate compound so formed is immediately decarboxylated to 5-HT by a decarboxylase enzyme, the **amino acid decarboxylase**. This

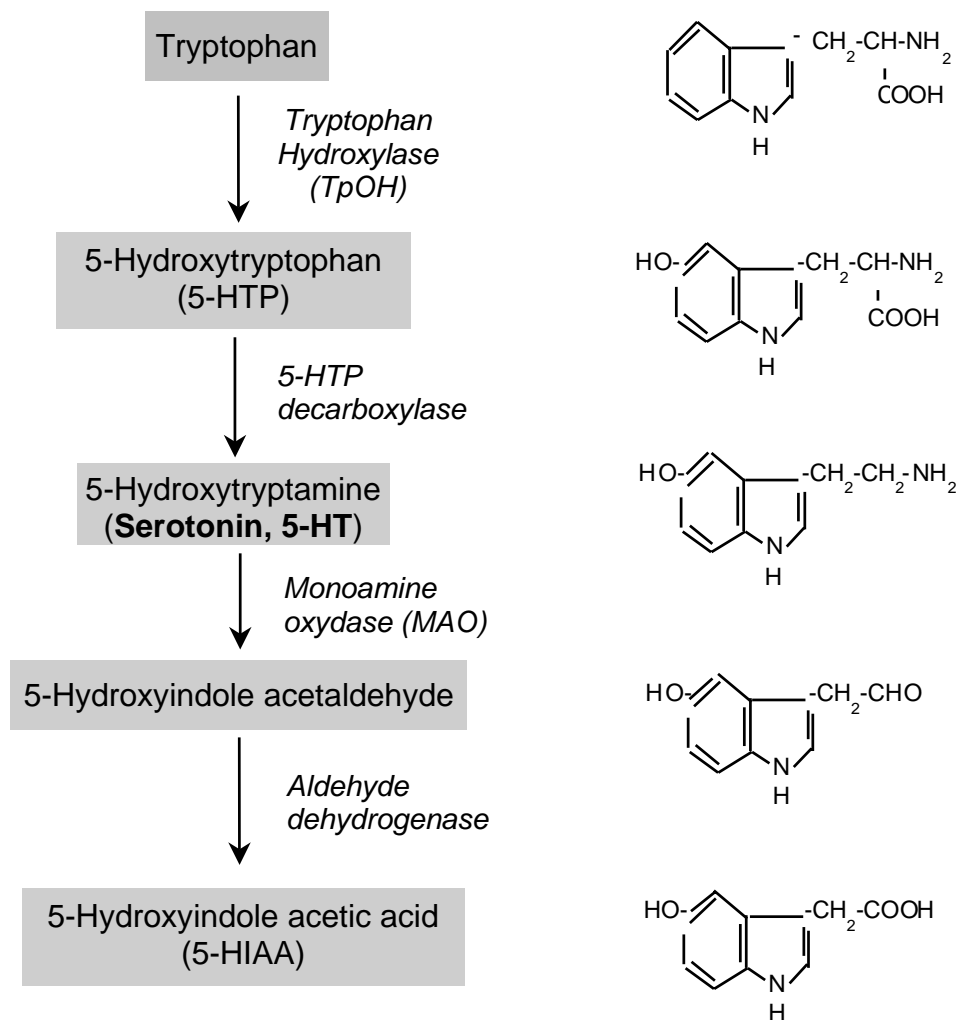

Figure 18. The biosynthesis and the main catabolism pathway of serotonin. The involved enzymes are indicated in italic.

enzyme, present in excess in the brain, is not limitant for 5-HT synthesis, in contrast to the TpOH.

Degradation

After release in synaptic space, 5-HT can be recaptured by the neurons through an active re-uptake process, provided by **5-HT transporters**. Within the neurons, 5-HT is again stored in synaptic vesicles or metabolized. This degradation is realized in two steps. The mitochondrial enzyme **monoamine oxidase (MAO)** converts 5-HT in an instable compound,

the **5-hydroxyindole acetaldehyde** which is then oxidated by the **aldehyde dehydrogenase** in **5-hydroxyindole acetic acid (5-HIAA)**.

IV.1.2.2. Storage and release of 5-HT

Storage of 5-HT is realized by transporters located in the vesicles membrane (Halaris and DeMet, 1978). In these vesicles, 5-HT is bound to a specific protein, the **serotonin binding protein (SBP)**, to form the 5-HT-SBP complexe (Gershon *et al.*, 1983).

The two most likely mechanisms involved in of 5-HT release concern the activity of **presynaptic autoreceptors and heteroreceptors** and also the firing of the 5-HT neurons (for review, see Blier *et al.*, 1998). After release in the synaptic cleft, the 5-HT-SBP complexe is dissociated and 5-HT can bind to 5-HT receptors. But in the DRN, 5-HT release appears to be realized not via synapses, but directly from dendrite and cell body (Descarries *et al.*, 1982). This release could play a role in the regulation of 5-HT neurons firing rate.

IV.1.2.3. Electrical activity of 5-HT neurons

Serotonergic neurons are characterized by a **slow and regular discharge**. Results obtained *in vivo* in anesthetized and vigil animals show the endogenous characteristic of electrical activity in 5-HT neurons. Indeed, when isolated from its afferences, the DRN still displayed a slow rhythmic discharge pattern (Mosko and Jacobs, 1977). Moreover, *in vivo* intracellular recordings provided evidence for an **intrinsic activity** of the brain serotonergic neurons (Aghajanian and Vandermaelen, 1982).

The 5-HT neurons electrical activity can be regulated by different factors. **Sleep-wake cycle** is one of these factors. In cats, during the **waking state**, the activity of DRN serotonergic neurons was slow and highly regular (Trulson and Jacobs, 1979). But when cats enter **slow-wave-sleep**, neuronal activity displayed a decrease in rate and loss of regularity. Moreover, during **rapid-eye-movement (REM) sleep**, DRN 5-HT neurons showed a complete loss of electrical activity. 5-HT release is closely related to the neuronal firing: release is minimal during period of REM sleep and the greatest during the active phase. Results obtained in rats are in accordance with those in cats, high levels of 5-HT were measured in awaked animals and the lowest concentrations were obtained during their REM sleep (Kalen *et al.*, 1989). At cellular level, electrical activity of 5-HTergic neurons can be

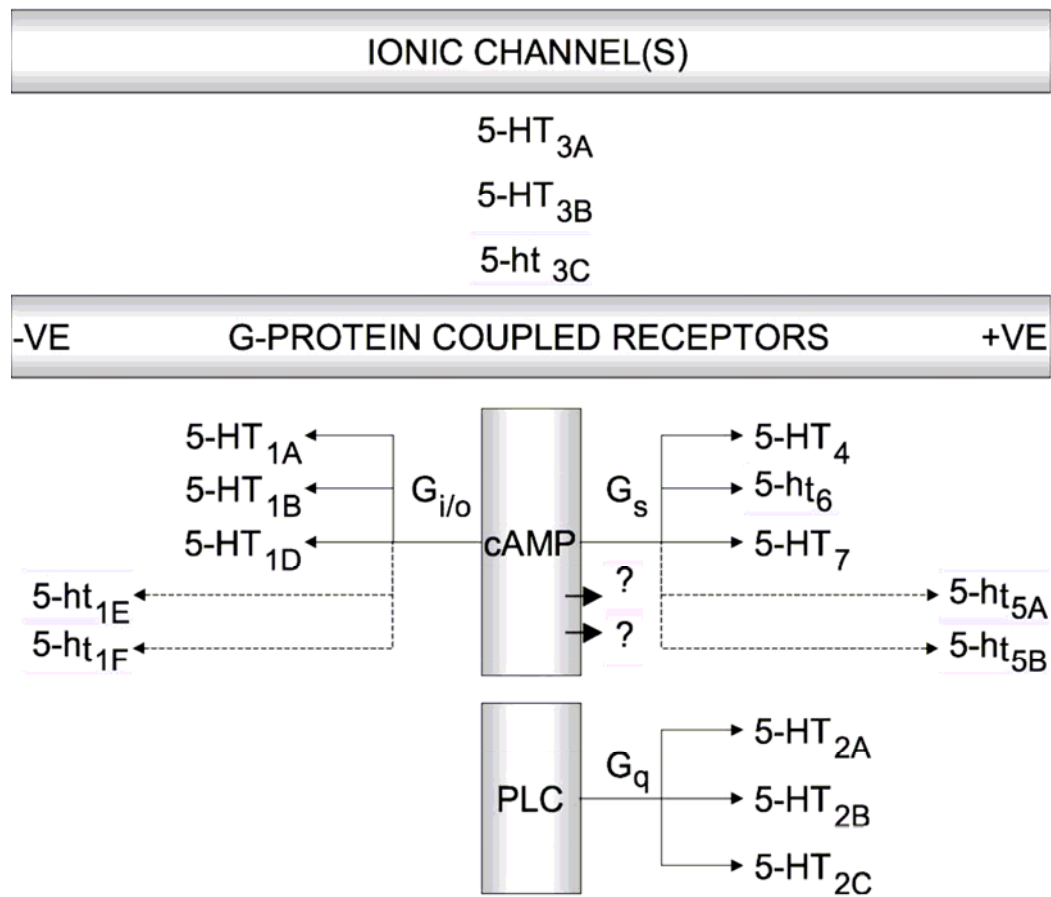

Figure 19. Graphical representation of the current classification of 5-HT receptors. Receptor subtypes represented by gray boxes and lower case designate receptors that have not been demonstrated to definitively function in native systems. Abbreviations: 30-50 cyclic adenosine monophosphate (cAMP); phospholipase C (PLC); negative (_ve); positive (+ ve).

From Hoyer et al., 2002.

reduced by 5-HT itself, but also by GABA, histamine and glycine. Noradrenaline and glutamate induce an increase of the firing rate of these neurons.

IV.1.3. Serotonergic receptors

It can be distinguished **7 different 5-HT receptor classes, 5-HT₁ to 5-HT₇**, based on gene sequence, structure, intracellular signaling cascade (Fig. 19) and pharmacology (Table 3). With the exception of the **5-HT₃ receptor**, which is a **ligand-gated ion channel**, 5-HT receptors belong to the **G-protein-coupled receptor superfamily**. Moreover, depending on the cellular localization, the 5-HT receptors can be **autoreceptors or heteroreceptors**, located on 5-HT neurons or on other neurons, respectively. In addition, 5-HT receptors can be **presynaptic**, located on fibers terminals or **postsynaptic**, located on dendrites or cell bodies. 5-ht receptors are given a lower case appellation to denote that endogenous receptors with a physiological role have not yet been found. In contrast, 5-HT receptors have been demonstrated functionally in a variety of tissues from various species. For review, see Hoyer *et al.*, 2002.

IV.1.3.1. The 5-HT₁ receptor class

The 5-HT₁ receptor class is composed of **5 receptor subtypes** (5-HT_{1A}, 5-HT_{1B}, 5-HT_{1D}, 5-ht_{1E} and 5-ht_{1F}). These receptors are composed of **7 transmembrane domains** and are **coupled to G_{i/o}** (G for protein G) to inhibit cAMP formation (Fig. 19).

5-HT_{1A} receptors

5-HT_{1A} receptors are widely distributed throughout the central nervous system. In the raphe nuclei, they are **somatodendritic** (located on dendrites and neurons soma) and act as autoreceptors to inhibit cell firing (Sprouse and Aghajanian, 1986), synthesis (Hillegaart *et al.*, 1990) and release of 5-HT (Hjorth and Sharp, 1991). The somatodendritic 5-HT release occurring in the DRN (Hery *et al.*, 1986) thus controls electrical activity as well as metabolism of serotonergic neurons, via 5-HT_{1A} receptors. However, postsynaptic 5-HT_{1A} receptors are also present in a number of limbic structures, like hippocampus, septum, amygdala, cortex and SCN. Several agonists show selectivity for the 5-HT_{1A} receptor

(Table 3), particularly **8-OH-DPAT** which acts as a full agonist in most systems. Another agonist, **5-CT** (5-carboxamidotryptamine), is only a partial agonist since it also shows affinity for 5-HT_{1B}, 5-HT_{1D}, 5-HT₅ and 5-HT₇ receptors (Hoyer *et al.*, 1994). NAN-190 (Deans *et al.*, 1989) as well as pindolol (Oksenberg and Peroutka, 1988) are thought to be 5-HT_{1A} antagonists. However, the only selective high-affinity silent antagonist of this 5-HT_{1A} receptor is **WAY 100635** (Forster *et al.*, 1995).

5-HT_{1B} receptors

5-HT_{1B} receptors are expressed in the central nervous system, concentrated in the frontal cortex, basal ganglia, striatum, SCN and are thought to serve as **presynaptic autoreceptors**. In this case, they are involved in the control of 5-HT release (Gothert *et al.*, 1987). In addition, the receptor may also act as a **presynaptic heteroreceptor** controlling the release of other neurotransmitters, such as acetylcholine, glutamate, dopamine, noradrenaline and GABA (Pauwels, 1997). In the SCN, this receptor has been shown to be precisely located on the terminals of the RHT and the GHT (Manrique *et al.*, 1999). 5-CT can be considered a 5-HT_{1B} agonist. However, this compound binds also to 5-HT_{1A}, 5-HT_{1D}, 5-HT₅ and 5-HT₇ receptors (Hoyer *et al.*, 1994). Moreover, 1-(3-trifluoromethylphenyl) piperazine (**TFMPP**) is a selective 5-HT_{1B} agonist (McKenney and Glennon, 1986), but is also known to be specific to the other 5-HT₁ receptors. With respect to antagonists, there are few with high selectivity for the 5-HT_{1B} receptor. The 5-HT_{1B} antagonists, that are most commonly used in rodents, i.e. pindolol, are also equipotent for the 5-HT_{1A} receptor, but with antagonist or partial agonist properties.

5-HT_{1D} receptors

5-HT_{1D} has a high level of sequence homology with 5-HT_{1B} and 5-CT is an agonist for both. However, pharmacology properties between these two receptors are relatively different. Compared with 5-HT_{1B} receptors, 5-HT_{1D} level of expression is very low and appears to be present in the DRN (Roberts and Price, 2001) and in the trigeminal ganglia (Hou *et al.*, 2001). The only 5-HT_{1D} agonist to date is the PNU 109291 (Table 3). BRL 15572 is a specific 5-HT_{1D} antagonist.

5-HT₁ receptors

Nomenclature	5-HT _{1A}	5-HT _{1B}	5-HT _{1D}	5-ht _{1E}	5-ht _{1F}
Agonists	8-OH-DPAT 5-CT	TFMPP 5-CT	PNU 109291 5-CT	–	LY 334370
Antagonists	(±)WAY 100635 Pindolol NAN-190	Pindolol	BRL 15572	–	–
Radioligands	[³ H]WAY100635 [³ H]8-OH-DPAT	[¹²⁵ I]GTI [¹²⁵ I]CYP [³ H]Sumatriptan [³ H]GR 125743	[¹²⁵ I]GTI [³ H]Sumatriptan [³ H]GR 125743	[³ H]5-HT	[¹²⁵ I]LSD [³ H]LY 334370

5-HT_{2,3,4} receptors

Nomenclature	5-HT _{2A}	5-HT _{2B}	5-HT _{2C}	5-HT ₃	5-HT ₄
Agonists	DOI DOB	DOI DOB BW 723C86	Ro 600175 DOI mCPP	m-CPBG	BIMU 8
Antagonists	MDL 100907	SB 200646	SB 242084	ondansetron	GR 113808
Radioligands	[¹²⁵ I]DOI [³ H]Ketanserin [³ H]MDL 100907	[³ H]5-HT	[¹²⁵ I]LSD [³ H]Mesulergine	[³ H](S)-zacopride [³ H]tropisetron [³ H]granisetron [³ H]GR 65630	[¹²⁵ I]SB 207710 [³ H]GR 113808 [³ H]RS 57639

5-HT_{5,6,7} receptors

Nomenclature	5-ht _{5A}	5-ht _{5B}	5-ht ₆	5-HT ₇
Agonists	5-CT	5-CT	–	8-OH-DPAT 5-CT
Antagonists	–	–	SB 271046	DR 4004 SB 269970
Radioligands	[¹²⁵ I]LSD [³ H]5-CT	[¹²⁵ I]LSD [³ H]5-CT	[¹²⁵ I]SB 258585 [¹²⁵ I]LSD [³ H]5-HT	[¹²⁵ I]LSD [³ H]SB 269970 [³ H]5-CT [³ H]5-HT

Table 3. 5-HT receptors specific agonists, antagonists and radioligands. Modified from Hoyer et al., 2002.

5-ht_{1E} receptors

The putative 5-ht_{1E} receptor was identified in binding studies in homogenates of human frontal cortex, but it was not possible to readily determine its overall distribution and to confirm a true physiological role, since selective ligands are currently unavailable.

5-ht_{1F} receptors

Little is known about the distribution and function of the 5-ht_{1F} receptor. However, mRNA for the human receptor has been identified in the brain, concentrated in the dorsal raphe, hippocampus, cortex, striatum, thalamus and hypothalamus. LY 334370 is a selective 5-ht_{1F} receptor agonist and has also been used as a radioligand (Table 3).

IV.1.3.2. The 5-HT₂ receptor class

This class comprises the 5-HT_{2A}, 5-HT_{2B} and 5-HT_{2C} receptors, which exhibit 46 to 50% overall sequence identity. They are composed of **7 transmembrane domains** and are coupled preferentially to **G_{q/11}** to increase, through PLC, the hydrolysis of inositol phosphates and elevate cytosolic [Ca²⁺] (Fig. 18).

5-HT_{2A} receptors

The 5-HT_{2A} receptor is widely distributed in central tissues: neocortex, claustrum, basal ganglia and SCN (Moyer and Kennaway, 1999). The agonists described are not truly selective since **DOI** and **DOB** also recognize other receptors of the 5-HT₂ receptor class. MDL 100907, the most selective agent in terms of 5-HT_{2A} affinity, is an antagonist.

5-HT_{2B} receptors

5-HT_{2B} receptor immunoreactivity has been reported and is restricted to a few brain regions particularly cerebellum, hypothalamus, medial amygdala and lateral septum (Duxon *et al.*, 1997). A 5-HT_{2B} selective agonist, BW 723C86 (Kennett *et al.*, 1997), as well as selective antagonists, SB 200646 (Kennett *et al.*, 1994) are available.

5-HT_{2C} receptors

The 5-HT_{2C} receptor was one of the first of this family to be cloned (Loric *et al.*, 1992). It is expressed in choroid plexus, in basal ganglia, hippocampus, in the limbic structures of the brain, in the hypothalamus and particularly in the SCN (Moyer and Kennaway, 1999). Due to the lack of truly selective 5-HT_{2C} receptor ligands, our current knowledge concerning a functional role of this receptor is rather limited. However, Ro 600175, DOI and **mCPP** represent moderately selective agonists. Moreover, DOI is also able to recognize 5-HT_{2A} receptors binding sites and mCPP shows also affinity for 5-HT_{2A} and 5-HT₃ receptors (Zifa and Fillion, 1992). **SB 242084** is a 5-HT_{2C} antagonist.

IV.1.3.3. The 5-HT₃ receptor class: an intrinsic ligand-gated channel

This **nonselective cation channel** (Na⁺, Ca²⁺ and K⁺) has similar electrophysiological properties as the nicotonic acetylcholine or GABA_A channels (Boess and Martin, 1994). Its activation leads to a transient inward current and thus induces a rapid depolarisation of the neuron and **subsequent neurotransmitter release**. 5-HT₃ receptors are involved in the modulation of different neurotransmitter's release as demonstrated for noradrenaline in the hippocampus (Feuerstein and Hertting, 1986), dopamine in the nucleus accumbens and amygdala (De Deurwaerdere *et al.*, 1998), GABA in the spinal cord (Kawamata *et al.*, 2003) and for glutamate in the area postrema (Funahashi *et al.*, 2004). 5-HT₃ receptors are pentamers (Boess *et al.*, 1995). There are two 5-HT₃ subtypes: 5-HT_{3A} and 5-HT_{3B}. The 5-HT_{3A} receptor is present in two splice variants (a long and a short variant) that appear to possess similar distributions, pharmacological profiles and electrophysiology characteristics (Miquel *et al.*, 1995). However, the distribution of the second subtype, the 5-HT_{3B} receptor, seems to be different from that of the 5-HT_{3A} receptor (Morales and Wang, 2002). Moreover, it appears that the heteromeric combination of 5-HT_{3A} and 5-HT_{3B} subunits is necessary to provide the full functional features of the 5-HT₃ receptor, since each subunit alone results in receptors with very low conductance and response amplitude (Dubin *et al.*, 1999). 5-HT₃ receptors are present in several brain regions, including the hippocampus, the nucleus accumbens, the amygdala, the dorsal motor nucleus of the solitary tract and the area postrema (Laporte *et al.*, 1992). One specific 5-HT₃ agonist is **m-CPBG**. **Ondansetron** is a selective 5-HT₃ antagonist.

IV.1.3.4. The 5-HT_{4,6,7} receptors

The 5-HT₄, 5-HT₆ and 5-HT₇ receptors are all coupled preferentially to Gs and promote cAMP formation.

5-HT₄ receptors

Seven C-terminal splice variants of the receptor have been identified (5-HT_{4A-H}; Blondel *et al.*, 1997). The pharmacology of the variants seems to be similar in contrary to their distribution. This receptor subtype is present in the striatum, in the substantia nigra, in the olfactory bulb and limbic structures of the brain. 5-HT₄ receptors in the central nervous system appear to modulate neurotransmitter (acetylcholine, dopamine, serotonin and GABA) release and enhance synaptic transmission. Several potent and selective 5-HT₄ receptor ligands are now available, such as the agonists BIMU 8 (Eglen, 1997) and the antagonists GR113808 (Bonhaus *et al.*, 1994).

5-HT₆ receptors

The 5-HT₆ receptor mRNA is located in the striatum, amygdala, nucleus accumbens, hippocampus, neocortex and olfactory tubercle. Selective antagonists become now available, for example, SB 271046. However, there is to date no specific 5-HT₆ agonists.

5-HT₇ receptors

Alternate splicing of other 5-HT₇ receptor has been reported to generate four different isoforms (5-HT_{7A-D}), which differ in their C-terminal region (Heidmann *et al.*, 1997). However, these isoforms have been shown to be rather similar in their respective pharmacology, signal transduction or tissue distribution (Jasper *et al.*, 1997). Autoradiographic analysis revealed 5-HT₇ binding sites in the thalamus and the hypothalamus and more precisely in the SCN (Moyer and Kennaway, 1999), with more moderate binding densities in the hippocampus, the brain stem, cerebral cortex and with even lower binding densities in the amygdala, cerebellum, superior colliculus and raphe nuclei. Moreover, the cellular localization of rat hypothalamic 5-HT₇ receptors was suggested to be postsynaptic

(Clemett *et al.*, 1999). Despite the lack of selective 5-HT₇ agonists, prototypical 5-HT₁ agonists, like 8-OH-DPAT or 5-CT, have also a high affinity for the 5-HT₇ receptor. DR4004 is a specific antagonist (Kikuchi *et al.*, 1999), but has also affinity for the dopamine D2 receptor (Kogan *et al.*, 2002). SB 269970 is also a selective 5-HT₇ antagonist (Hagan *et al.*, 2000).

IV.1.3.5. The 5-HT₅ receptors

Two subtypes of the 5-HT₅ receptor (5-HT_{5A} and 5-HT_{5B}) have been found in rodents. The receptor transduction mechanism has been suggested by Carson *et al.* (1996): it seems that they are negatively coupled to Gi and Go and that they induce subsequent inhibition of cAMP production. Labelled structures include the hypothalamus, hippocampus, fimbria, corpus callosum, and cerebral ventricles. The morphology and distribution of the cells labelled with antiserum were consistent with those of astrocytes (codistribution with GFAP was prominent), except in the olfactory bulbs and cortex where low levels were associated with neurons. No specific agonists or antagonists are available up to now. However, 5-CT binds also to 5-HT₅ receptors.

IV.2. The serotonergic system: relationship with the circadian system

IV.2.1. Circadian control of serotonergic system

The circadian control on the serotonergic system can be realized at different levels of serotonin synthesis, degradation or release.

IV.2.1.1. Tryptophan availability and uptake

Several studies have reported daily rhythms in both plasma and brain tryptophan concentrations in parallel to 5-HT levels (Hussein and Goedde, 1979). However, it seems **unlikely that tryptophan levels play a critical role in variations of central 5-HT concentrations**. Indeed, 100 % increase in brain tryptophan levels resulted in a 10 – 15 %

increase in 5-HT concentrations (Leathwood, 1987). Since endogenous variations in brain tryptophan are less than 2-fold, it is unlikely that circadian fluctuations of tryptophan are responsible for daily changes in 5-HT concentrations.

However, it is possible that **variations of tryptophan uptake**, that enable transport of tryptophan from the general circulation into neurons, may be an important factor responsible for daily variations of 5-HT levels. Indeed in 1988, Loizou and Redfern investigated tryptophan uptake in cortical rat synaptosomes. Their results showed a variation of tryptophan uptake rate with maximal values at the middle of the day. Thus, it is generally believed that the limiting factor of 5-HT synthesis is related in part to the control of tryptophan uptake into serotonergic neurones.

IV.2.1.2. TpH and 5-HTP decarboxylase quantity and activity

The **limiting step** in 5-HT synthesis is the **conversion of tryptophan in 5-HTP** by the TpH. **Circadian rhythmicity of TpH mRNA** in raphe nuclei has been demonstrated with a peak at the end of the subjective day (Malek *et al.*, 2005; in press). Moreover, **TpH protein** levels shows a circadian rhythmicity in the raphe with a peak in the middle of the subjective night (Malek *et al.*, 2004). This circadian rhythm of TpH protein was also shown in the SCN (Barassin *et al.*, 2002) and in the IGL (Malek *et al.*, 2004), however with a delayed peak level at the end of the subjective day. Thus, it seems likely that TpH is first expressed in the raphe nuclei (Ehret *et al.*, 1987), then transported in the axons to the SCN and the IGL. The persistence of a TpH mRNA and protein rhythmicity in DD demonstrates the circadian regulation of the TpH expression. TpH activity has been investigated by several groups but contradictory results have been reported. While some authors found maximal enzyme activity in the middle of the light phase (Kan *et al.*, 1977), others failed to demonstrate any variation of TpH activity (McLennan and Lees, 1978). The reason for this diversity could be due to the variety of experimental techniques used. Therefore, no definitive conclusion concerning a circadian rhythmicity of the enzyme activity can be drawn here.

The mechanisms of circadian control of TpH are still unknown. Nevertheless, it seems likely that **glucocorticoids can modulate the expression as well as the activity of TpH**. Indeed, an immobilisation stress can elevate tryptophan hydroxylase mRNA and protein in the rat raphe nuclei (Chamas *et al.*, 2004). In addition, chronic injections of glucocorticoids or corticosteroid compounds induced an increase of TPH mRNA (Clark and Russo, 1997),

protein (Azmitia *et al.*, 1993) and activity (Singh *et al.*, 1990). Given that corticosterone is a well known SCN output, one could hypothesize a circadian control of TpH expression and of its activity via glucocorticoids plasma level (Malek *et al.*, in preparation).

In the central nervous system, the activity of 5-HTP decarboxylase is much higher than that of the rate limiting enzyme TpH. Since 5-HTP is rapidly transformed into 5-HT, tissue concentrations of 5-HTP are low, and it is generally considered that the activity of the decarboxylase enzyme does not play any role in the control of 5-HT synthesis.

IV.2.1.3. Serotonin content and release

Whole brain 5-HT levels were first reported to vary over the day in mice (Albrecht *et al.*, 1956). Subsequently, similar findings have been reported for numerous other species, including humans (Bucht *et al.*, 1981), rats (Kan *et al.*, 1977) and Syrian hamsters, especially in the raphe nuclei and paraventricular nucleus (Ozaki *et al.*, 1993). In the rat, 5-HT levels in the brain are maximal during the day and low during the night (Quay, 1968).

New techniques such as *in vivo* voltammetry or microdialysis have been developed and these tools allowed the measurement of extracellular levels of 5-HT and 5-HIAA. Since MAO activity did not present diurnal variations, 5-HIAA only was first used as a tracer for 5-HT release. Indeed, owing technical problems, it was possible to measure 5-HIAA extracellular level, but not 5-HT. Faradji *et al.* in 1983 reported a clear **circadian pattern of 5-HIAA level in the rat SCN** using *in vivo* voltammetry. Furthermore, the use of a nafion-coated carbon fiber electrodes excluding 5-HIAA, enabled the measurement of 5-HT extracellular level. Moreover, microdialysis technic enabled direct measurements of 5-HT release rhythm and provided the evidence that 5-HT release in the SCN shows a peak at the beginning of the subjective night in the hamster (Dudley *et al.*, 1998) and the rat (Barassin *et al.*, 2002). The same pattern of 5-HT release was detected in the IGL in the hamster (Grossman *et al.*, 2004).

IV.2.2. Role of serotonin in circadian rhythms

It was first difficult to define a specific role of serotonin. Indeed, 5-HT depletion and lesion studies revealed only subtle effects on circadian rhythmicity. For example, in Syrian hamsters, chemical **lesions of the serotonergic system** by application of the 5,7-DHT (5,7-dihydroxytryptamine) neurotoxin resulted in a **lengthening of the activity duration α**

both under LD and DD conditions (Smale *et al.*, 1990; Meyer-Bernstein *et al.*, 1997). However, under constant light (LL) conditions, the increase of tau in control animals (Aschoff, 1959) was prevented by the lesion of the raphe nucleus (Meyer-Bernstein *et al.*, 1997), indicating a modulatory effect of 5-HT in the transmission of light information to the SCN. Further data obtained after acute applications of 5-HT agonists and antagonists in hamsters, mice and rats indicated that serotonin plays an important role in the entrainment of the circadian clock but this role varies with the species (Kohler *et al.*, 2000).

IV.2.2.1. Role of serotonin in the Syrian hamster

In hamsters, the SCN receives a direct serotonergic projection from the MRN as well as an indirect input from the DRN through the IGL (Meyer-Bernstein and Morin, 1996) (Fig. 9). Experimental evidence obtained so far in **Syrian hamsters** suggests that **5-HT mimics the effect of non-photic stimuli during the subjective day and modulates photic input to the SCN during the subjective night.**

Actually, serotonin release was increased in the SCN in response to an induced activity (Dudley *et al.*, 1998) and to sleep deprivation (Grossman *et al.*, 2000) during the subjective day. Moreover, 5-HT agonists mimicked the phase shifting effects of non-photic stimuli (Cutrera *et al.*, 1996). Systemic injections of 5-HT agonists such as 8-OH-DPAT during the subjective day induced phase advances of the locomotor activity, but very little or no phase shifts during the subjective night, in LL (Tominaga *et al.*, 1992b) as well as in DD conditions (Cutrera *et al.*, 1994a). Similar results were obtained after local injection of 8-OH-DPAT in the SCN (Challet *et al.*, 1998c). Moreover, electrical stimulation of the DRN and the MRN, leading to 5-HT release in the SCN, induced phase advances of the locomotor activity rhythm (Meyer-Bernstein and Morin, 1999). In addition, 8-OH-DPAT injections at the middle of the subjective day decreased *Per1* and *Per2* mRNA levels in the SCN (Horikawa *et al.*, 2000; Caldelas *et al.*, 2005) as did non-photic stimuli, like novel-wheel running (Maywood *et al.*, 1999). These effects seem to be mediated by the 5-HT_{1A} receptor subtype since pindolol, a 5-HT_{1A} antagonist, was able to block the effect of 8-OH-DPAT on the locomotor activity rhythm (Tominaga *et al.*, 1992b). However, it seems likely that the 5-HT₇ receptors are also involved, since the effects of a systemic 8-OH-DPAT injection were blocked by DR4004, a specific 5-HT₇ antagonist (Ehlen *et al.*, 2001). Furthermore, phase advances induced by arousal due to triazolam (Cutrera *et al.*, 1994b), but not novel-wheel running (Bobrzynska *et*

al., 1996), were reduced by the 5-HT fibers lesion, resulting from the application of the 5,7-DHT neurotoxin (Meyer-Bernstein and Morin, 1998) or blockade of serotonergic transmission, induced by reserpine injection (Penev *et al.*, 1994). Similar results could be obtained with pretreatment with 5-HT antagonists (Sumova *et al.*, 1996). In addition, a few studies indicated that 5-HT fibers from the DRN projecting to the IGL can play a role in non-photic phase shifting effects. Daytime microinjections of 8-OH-DPAT into the IGL induced phase advances of the locomotor activity (Challet *et al.*, 1998c). These findings are consistent with a putative role of serotonergic pathways in the transmission of arousal state to the SCN.

Besides direct effects on the SCN clock during the subjective day, **5-HT** is thought to play a role in **decreasing the light-induced phase shifts during the subjective night**. Systemic (Rea *et al.*, 1994) as well as local injections of 8-OH-DPAT (Weber *et al.*, 1998) decreased the magnitude of light-induced phase shifts of locomotor activity rhythm. Moreover, 8-OH-DPAT blocked the light-induced firing increase of SCN neurons (Rea *et al.*, 1994; Ying and Rusak, 1994), extracellular glutamate in the SCN (Srkalovic *et al.*, 1994), as well as stimulation of c-Fos protein immunoreactivity in SCN cells (Rea *et al.*, 1994). Similar results were obtained with 5-HT (Selim *et al.*, 1993; Ying and Rusak, 1994), quipazine (Selim *et al.*, 1993), 5-CT (Ying and Rusak, 1997) or TFMPP (Srkalovic *et al.*, 1994; Pickard *et al.*, 1996). This inhibition of light-induced effects seems to be mediated by the 5-HT_{1B} receptors, since systemic as well as local injections of different 5-HT_{1B} agonists into the SCN, reduced light-induced effects and phase shifts of the locomotor activity rhythm as well as c-Fos expression in the SCN neurons (Pickard *et al.*, 1996).

IV.2.2.2. Role of serotonin in the mouse

Results obtained *in vivo* in mice were **almost the same as those gathered in hamsters**, both during the subjective day (Horikawa and Shibata, 2004) and the subjective night (Pickard and Rea, 1997; Pickard *et al.*, 1999). Moreover, it has been shown that in mouse, like in hamster, 5-HT is involved in the effects of non-photic cues on the clock. Indeed, local injection of the 5,7-DHT neurotoxin in the SCN, blocked the circadian effect of a scheduled 2 h wheel running paradigm (Edgar *et al.*, 1997). In addition, *in vitro* studies demonstrated the involvement of 5-HT_{1B} as well as 5-HT₇ receptors in the inhibition of light-induced glutamatergic excitatory postsynaptic currents (EPSCs) evoked by selectively stimulating the

optic nerve (Pickard *et al.*, 1999; Smith *et al.*, 2001). The cellular localization of the 5-HT_{1B} receptor involved has been shown to be presynaptic on axon terminals (Boschert *et al.*, 1994) and more precisely on the RHT (Pickard *et al.*, 1999).

The receptor affinities are, nevertheless, slightly distinct from those in hamsters. Indeed, (±)8-OH-DPAT systemic injections in the mouse induced only little effects on the locomotor activity rhythm and on c-FOS expression in the SCN in contrast to the large effects obtained in hamsters (Antle *et al.*, 2003). However, (+)8-OH-DPAT, an enantiomer of the latter compound, has been shown to phase advance the locomotor activity rhythm when injected during the subjective day (Horikawa and Shibata, 2004).

IV.2.2.3. Role of serotonin in the rat

In rats, contrary to what has been observed in hamsters, the SCN receives a direct serotonergic projection from both MRN and DRN, while the IGL receives only 5-HT input from the DRN (Hay-Schmidt *et al.*, 2003). Moreover, the DRN receives a small retinal projection (Shen and Semba, 1994).

First, **5-HT seems to be involved in the effects of timed caloric restriction**. Indeed, lesion of 5-HT fibers in the SCN, after injection of the 5,7-DHT neurotoxin, limited the phase advance of both body temperature and locomotor activity rhythms induced by a daytime caloric restriction (Challet *et al.*, 1997e). Moreover, the 5-HT input from the DRN to the IGL seems also to play a role, since IGL lesion decreased phase advances induced by a timed caloric restriction in LD (Challet *et al.*, 1996b).

Second, a former study showed that quipazine as well as 8-OH-DPAT injected during the day induce a phase advance of the locomotor activity rhythm (Edgar *et al.*, 1993) suggesting that 5-HT in rats has similar effects as those in hamsters. However, several recent studies showed that **5-HT seems to enhance**, rather than reduce, **photic responses in rats**. Indeed, systemic injections of 5-HT agonists such as quipazine or the more specific 5-HT_{2C} agonists, DOI and mCPP, but not 8-OH-DPAT have been shown to mimic the phase shifting effects of light on the circadian rhythms of locomotor activity and melatonin (Kennaway *et al.*, 1996; Kennaway and Moyer, 1998, 1999; Kohler *et al.*, 1999; Fig. 20). Furthermore, it has been shown that similar to light, quipazine (Moyer *et al.*, 1997) and other 5-HT agonists such as DOI injected at the periphery induce c-Fos expression in the ventrolateral area of the SCN during the subjective night, but not during the subjective day (Moyer *et al.*, 1997;

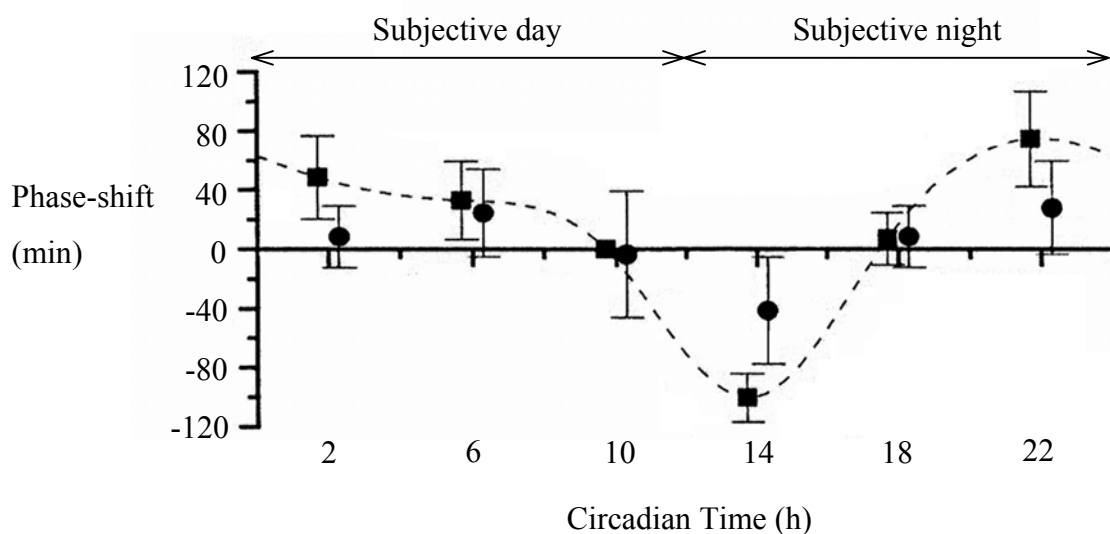

Figure 20. Phase response curves (dashed line) for quipazine in the rat. Mean phase shifts \pm SD are represented for quipazine in squares and for saline in circles (From Kohler et al., 1999).

Kennaway and Moyer, 1998, 1999; Kohler *et al.*, 1999). Similar effects of quipazine were demonstrated after its local injection into the SCN (Kalkowski and Wollnik, 1999). Moreover, as for the light, DOI could induce the expression of *Per1* and *Per2* during the subjective night (Varcoe *et al.*, 2003). It has been proposed by the team of Kennaway that the 5-HT_{2C} receptor mediates these photic-like effects of 5-HT, because effects of DOI on melatonin rhythm as well as on c-FOS expression in the SCN were blocked by pretreatment with the specific 5-HT_{2C} antagonist SB-242084 (Kennaway *et al.*, 2001). Moreover, the presence of the 5-HT_{2C} receptors in the SCN has been confirmed by *in situ* hybridization (Roca *et al.*, 1993) and immunohistology (Moyer and Kennaway, 1999). In addition, the 5-HT modulation of light effects during the night has been tested as done in the hamster. Nevertheless, the reduction of light-induced c-Fos expression in the SCN by 8-OH-DPAT injections was smaller in rats (Recio *et al.*, 1996) compared to hamsters (Glass *et al.*, 1994). Furthermore, light-induced c-Fos expression in the rat SCN was even more reduced after application of the 5-HT antagonist NAN-190 (Recio *et al.*, 1996), whereas in hamsters NAN-190 potentiated light-induced c-Fos expression (Rea *et al.*, 1995). Therefore, the inhibitory effect of 5-HT on photic responses of the circadian pacemaker that has been shown in hamsters, appears to be weaker or absent in rats.

However, concerning *in vitro* studies on rat SCN slices, photic-like effects have not been observed. On the contrary, non-photic effects of the 5-HT agonist quipazine on the SCN neurons firing rate rhythm have been demonstrated, but with a higher amplitude than *in vivo* on the locomotor activity rhythm (Prosser *et al.*, 1990; Prosser, 2003). Moreover, these effects are not reduced by the application of TTX (Prosser *et al.*, 1992), known to block synaptic transmission, providing evidence for a direct effect of this agonist, via post-synaptic receptors on the SCN cells. Similar results were obtained with 5-HT, 8-OH-DPAT and 5-CT (Medanic and Gillette, 1992; Prosser *et al.*, 1993). In addition, quipazine, failed *in vitro* to induce *c-fos* mRNA during the subjective night (Prosser *et al.*, 1994b). A recent study suggests that the 5-HT_{5A} receptors could be involved in these effects (Sprouse *et al.*, 2005). Moreover, 5-HT is able to reduce the field potentials in the suprachiasmatic nucleus of slices of hypothalamus evoked by stimulation of the optic nerve (Liou *et al.*, 1986). These results are similar to those obtained *in vivo* in hamsters. These differences between the *in vitro* and *in vivo* effects of quipazine in rats could suggest that systemically administered quipazine may affect the circadian system not directly at the level of the SCN, but through other brain structures such as the raphe or the IGL. However, i.c.v. injections of quipazine in areas close to the SCN during the subjective night, induce photic-like phase shifts of locomotor activity rhythm as well as c-FOS expression in the ventrolateral SCN (Kalkowski and Wollnik, 1999), implicating 5-HT receptors (pre and/or post-synaptic) located in this region. Differences between *in vitro* and *in vivo* effects of quipazine in the rat may rather be due to the impairment of the SCN inputs in brain slice preparations.

Thus, the serotonergic system that strongly projects to the SCN, is controlled at different levels by the circadian system. In turn, serotonin released in the SCN has subtle and complex effects on the SCN, due to a large and diverse range of receptors. Moreover, these modulatory effects highly depend on the species and the circadian time.

Scope of the thesis

SCOPE OF THE THESIS

In order to be in phase with the daily environmental variations, the circadian system within the SCN integrates different external time cues (Zeitgebers) that can be either of photic nature (e.g. LD cycle) or not. These diverse factors are able to modulate each other to build a global input signal to the SCN. Moreover, the neurotransmitter serotonin (5-HT) seems to be a key component in the SCN entrainment. The aim of this thesis was thus to study the mechanisms of integration of two external cues: the LD cycle and a metabolic factor, i.e. a timed caloric restriction. In addition, the 5-HT system being involved in this entrainment of the clock, we thus studied the neuronal mechanisms of the light-like phase shifting effect of 5-HT in rats.

In the first part of this thesis, we investigated the mechanisms of interaction between a photic factor, i.e. the LD cycle and a non-photoc factor, i.e. a timed caloric restriction (First part). We thus studied the interaction between these two Zeitgebers on the rhythms of locomotor activity, melatonin secretion and VP gene expression. We also analyzed the effect of these two factors on the rhythmic expression of different clock genes, in order to see a possible correlation between clock outputs and molecular mechanisms responsible for circadian rhythm generation of the clock. Moreover, we studied the effect of the diurnal hypocaloric feeding on the light responses of the SCN, i.e. light-induced phase shifts of the locomotor activity rhythm, inhibition of melatonin secretion and expression of clock genes.

Several data in the literature indicate that the 5-HT system, and more precisely the 5-HT input to the SCN, is involved in the effect of timed caloric restriction on the SCN (Challet *et al.*, 1997e). Moreover, 5-HT modulates the entrainment of the clock and has more precisely photic-like effects in rats by acting directly on the SCN (Kennaway *et al.*, 1996; Moyer *et al.*, 1997; Kennaway and Moyer, 1998, 1999; Kalkowski and Wollnik, 1999; Kohler *et al.*, 1999; Varcoe *et al.*, 2003). Our hypothesis was thus that 5-HT could play a role in the functional interaction between non-photoc and photic factors within the SCN. In order to further investigate this issue, we decided to study the neuronal mechanisms underlying the photic-like synchronizing effect of 5-HT on the SCN.

In the second part of this thesis, we first investigated the precise location of the 5-HT receptor(s) involved in these photic-like effects of 5-HT in rats (Second part; Article 2).

Indeed, this/these 5-HT receptor(s) could be presynaptic, located on the input terminals or postsynaptic, located on the SCN cells. The presynaptic hypothesis was tested by analyzing the effect of a non specific 5-HT agonist on locomotor activity rhythm as well as on c-FOS expression in the SCN of animals bearing a lesion of either the GHT, the 5-HT input or the RHT, the three main afferences of the SCN.

We then tried to find out which 5-HT receptor(s) subtype(s) is/are implicated in the photic-like effects of 5-HT (Second part; Article 3). In other brain structures, the 5-HT₃ receptor subtype has been shown to be located on glutamatergic terminals and to induce glutamate release when activated. These results and ours obtained in the Article 2. raised the possibility that the 5-HT₃ receptor subtype is involved in the photic-like synchronizing effect of 5-HT. We thus analyzed the respective effects of a specific 5-HT₃ agonist and a specific 5-HT₃ antagonist on three different parameters: locomotor activity rhythm, c-FOS expression and clock gene expression in the SCN.

Results

I. First part:

Interaction between a photic cue, i.e. the light-dark cycle and a non-photoc cue, i.e. a timed caloric restriction.

Introduction

Photic as well as non-photoc cues are able to synchronize the clock. Moreover, they can interact and modulate their respective effect, but the mechanisms of interaction are not yet well understood. We thus decided to study the interaction of a photic cue, i.e. the LD cycle, and a non-photoc cue, a timed caloric restriction. The effects of timed caloric restriction on different output parameters of the clock as well as on clock gene expression in the SCN in mice exposed to a LD cycle are presented in the following article.

Article 1

Feeding cues alter clock gene oscillations and photic responses in the suprachiasmatic nuclei of mice exposed to a light-dark cycle

Jorge Mendoza*, Caroline Graff*, Hugues Dardente, Paul Pévet and Etienne Challet

Journal of Neuroscience (2005) 25 : 1514-22.

* The first two authors contributed equally to the work.

Abstract

The suprachiasmatic nuclei (SCN) of the hypothalamus contain the master mammalian circadian clock, which is mainly reset by light. Temporal restricted feeding, a potent synchronizer of peripheral oscillators, has only weak influence on light-entrained rhythms via the SCN, unless restricted feeding is coupled with calorie restriction, thereby altering phase angle of photic synchronization. Effects of daytime restricted feeding were investigated on the mouse circadian system. Normocaloric feeding at midday led to a predominantly diurnal (60 %) food intake and decreased blood glucose in the afternoon, but it did not affect the phase of locomotor activity rhythm, or vasopressin expression in the SCN. By contrast, hypocaloric feeding at midday led to 2-4 h phase advances of three circadian outputs, locomotor activity rhythm, pineal melatonin, and vasopressin mRNA cycle in the SCN, and it decreased daily levels of blood glucose. Furthermore, *Per1* and *Cry2* oscillations in the SCN were phase advanced by 1 and 3 h respectively in hypocaloric- but not in normocaloric-fed mice. The phase of *Per2* and *Bmal1* expression remained unchanged regardless of feeding condition. Moreover, the shape of behavioral phase response curve to light and light-induced expression of *Per1* in the SCN were markedly modified in hypocaloric-fed mice compared to animals fed ad libitum. The present study shows that diurnal hypocaloric feeding affects not only the temporal organization of the SCN clockwork and circadian outputs in mice under light-dark cycle, but also photic responses of the circadian system, thus indicating that energy metabolism modulates circadian rhythmicity and gating of photic inputs in mammals.

Introduction

In mammals, the suprachiasmatic nuclei (SCN) of the hypothalamus contain the master circadian clock that coordinates the daily temporal organization of physiology and behavior. The SCN clock, which generates circadian rhythms, is synchronized to cyclic environmental changes, mainly the light-dark cycle (LD cycle; Takahashi *et al.*, 2001).

The molecular mechanisms underlying circadian rhythmicity involve self-sustaining transcriptional/translational feedback loops based on rhythmic expression of the mRNA and proteins of clock components. mRNA of three *Period* genes (*Per1*, *Per2* and *Per3*) oscillate with peak levels during daytime (Albrecht *et al.*, 1997; Zylka *et al.*, 1998). Transcription of *Per*, two *Cryptochrome* (*Cry1* and *Cry2*) *Rev-Erba* and two *Dec* (*Dec1* and *Dec2*) is activated

by heterodimers of transcription factors, CLOCK and BMAL1 (Kume *et al.*, 1999; Honma *et al.*, 2002; Preitner *et al.*, 2002). While *Clock* mRNA levels do not markedly oscillate in mouse SCN neurons (Shearman *et al.*, 2000b), *Bmal1* mRNA levels show daily variations with nocturnal peak and daytime trough (Abe *et al.*, 1998). Several clock proteins, including CRY and DEC, inhibit transcription of *Per* and *Cry* through binding to, or competition with, CLOCK/BMAL1 (Kume *et al.*, 1999; Honma *et al.*, 2002). Moreover, *Bmal1* transcription is repressed by REV-ERB α (Preitner *et al.*, 2002) and activated by ROR α (Sato *et al.*, 2004).

Synchronization of the SCN clock to light has been associated with increases of *Per1* and *Per2* mRNA (Albrecht *et al.*, 1997; 2001; Shigeyoshi *et al.*, 1997). Synchronizing effects of food availability differ largely from photic phase resetting. Behavioral outputs of light-synchronized SCN are usually not affected by restricted feeding (Mistlberger, 1994; Stephan, 2002). Accordingly, daily food access limited to daytime does not change clock gene expression in the SCN of rodents exposed to LD cycle (Damiola *et al.*, 2000; Hara *et al.*, 2001; Stokkan *et al.*, 2001; Wakamatsu *et al.*, 2001). When rats and C57BL mice kept under LD cycle are fed daily with only a hypocaloric diet, however, significant phase advances of circadian rhythms of melatonin, body temperature and locomotor activity have been detected (Challet *et al.*, 1997c; 1998d), suggesting that the phase of the SCN is modulated by feeding-related/metabolic cues.

Here we investigated the molecular mechanisms whereby timed calorie restriction alters the phase angle of photic synchronization. For this purpose, daily patterns of clock and clock-controlled gene expression were determined in the SCN of mice fed during daytime either with hypocaloric or normocaloric diet, and compared to ad lib-fed control animals. Moreover, phase shift responses of locomotor activity rhythm to light, light-induced suppression of pineal melatonin, and light-induced expression of clock genes in the SCN were compared between hypocaloric-fed and ad lib-fed mice.

Material and Methods

Animal housing and experimental design

Male, 8-wks old C3H mice (Charles Rivers, Lyon, France) were housed singly in cages equipped with a running wheel (10 cm diameter) in a room at 23 ± 1 °C with a 12-h light:12-h dark cycle (lights on at 5:00 AM) for 2-3 wks. Under LD conditions, times of day were converted to zeitgeber times (ZT), where ZT 0 and ZT 12 were the onsets of light and darkness, respectively. On the first day of constant darkness (DD), times of day were converted to projected ZT (pZT), where pZT 0 and pZT 12 were defined as the respective projected time of lights on and lights off in the previous lighting cycle. During daytime, light intensity was ~200 lux at the level of the cages. Food pellets and water were available *ad libitum* unless otherwise stated. Food pellets were composed of (per 100 g): 4 g fat, 20 g proteins, and 66 g carbohydrates (UAR, Epinay sur Orge, France). This diet contained 3.90 kcal/g, including 0.37 kcal/g from fat. All experiments were performed in accordance with the “Principles of laboratory animal care” (NIH publication 86-23, revised 1985) and the French national laws.

Behavioral phase shifts

To determine circadian rhythm of locomotor activity, wheel-running was continuously recorded in 24 mice (Experiment 1) and collected every 5 min as described before (Challet *et al.*, 2003). Mice were transferred to DD during 1 wk to assess the endogenous period (τ) of each animal (χ^2 periodogram, ClockLab software, Actimetrics, Evanston, USA). Mice were then returned to LD cycle with food *ad libitum* for 2 wks. Daily food intake was determined to be 5.4 g of chow. As in previous studies (Challet *et al.*, 1998d), mice were then randomly divided into three groups. The normocaloric-fed group received 100% of the mean daily food intake (i.e., 5.4 g) 6 h after the onset of light (i.e., at ZT 6). The hypocaloric-fed group was given 66% (i.e., 3.6 g) of the daily food intake at ZT 6. A third group of mice fed *ad libitum* served as control with a mean spontaneous food intake of 5.4 g. The period of food restriction lasted 3 wks. Thereafter, the mice were transferred to DD and fed *ad libitum* for 2 wks. On the

day of transfer to DD, lights were not switched on at pZT 0 and all the animals received food *ad libitum* from pZT 6. Body mass was measured weekly.

For assessment of phase changes in the SCN-controlled nocturnal period of activity, the onsets of nocturnal locomotor activity were determined during the last 8 days of *ad libitum* baseline conditions under LD cycle and from the second to ninth day of *ad libitum* (re)feeding in DD (ClockLab). To determine individual phase changes, a linear regression analysis of the onsets of activity (ClockLab) was performed by projecting the onset phase of the free-run in DD back to the mean onset phase under LD baseline conditions.

For assessment of the daily pattern of wheel-running activity, the cumulative wheel revolutions performed during eight 3 h intervals (ClockLab) starting at ZT 0 were determined during the last 8 days of *ad libitum* baseline conditions under LD cycle and the last 8 days of food restriction under LD cycle. Daily activity was defined as the total wheel revolutions per day averaged for each mouse over these two 8 day periods.

For assessment of the day-night pattern of food intake, food intake was measured by weighing remaining food pellets with a scale (Fisher Bioblock Scientific, Illkirch, France) at the nearest 0.1g during 12 h daytime and 12 h nighttime over 24 h at the end of *ad libitum* baseline conditions under LD cycle. During the 3rd wk of food restriction, food intake was measured over 24 h during five 3-h intervals from ZT 0 to ZT 15 and one 9 h interval from ZT 15 to ZT 24.

Circadian oscillations of clock genes

In Experiment 2, mice were exposed to 3 wks of food restriction under LD conditions as described for Experiment 1, and then transferred to DD (i.e., lights were not switched on at pZT 0). On this day without light, mice were sacrificed at 3 h intervals starting at projected time of lights on (i.e., pZT 0; $n=4$ per time point for a given feeding condition). Normocaloric-fed and hypocaloric-fed animals (except those already sacrificed at pZT 0, pZT 3 and pZT 6) were provided with respective diets at pZT 6, while control mice had food *ad libitum*. After isoflurane anesthesia and decapitation, brains were removed and stored at -80°C . Trunk blood was sampled to determine blood glucose (Glucotrend premium kit, Roche Diagnostics, Meylan, France). Antisense and sense RNA probes were generated with an *in vitro* transcription kit (Maxiscript, Ambion, USA). Here we used riboprobes of *rPer1*, *mPer2*, *mCry2* (from plasmids kindly provided by Dr. H. Okamura, University of Kobe,

Japan), *rVasopressin* (*VP*; see Dardente *et al.*, 2002) and *mBmallb*. *mBmallb* cDNA fragments were PCR-amplified using the following oligonucleotides: 5'--GCCCCACCGACCTACTCT-3' and 5'-CATCGTTACTGGGACTACTTGAT-3' (nuc. 55-1807 of GenBank accession number: AB012601). *mBmallb* PCR product of the expected size was cloned into the PCR-Script SK(+) cloning vector (Stratagene Europe, Amsterdam, the Netherlands). Identity and orientation of the cloned PCR fragment was confirmed by sequencing (AGOWA sequencing services, Berlin, Germany)., 14 μ m brain sections were post-fixed in 4 % phosphate buffered paraformaldehyde, rinsed with phosphate buffered saline (PBS) and sodium saline citrate (SSC), and then acetylated twice in 0.1 M triethanol-amine, washed again with SSC and PBS, treated with Tris 0.1 M containing glycine, rinsed with SSC and PBS, and dehydrated in a graded ethanol series. Sections were hybridized overnight with either denatured antisense or sense riboprobe in a humid chamber at 62 °C. Sections were then rinsed with SSC, treated with ribonuclease A (Sigma, St. Louis, MO), rinsed with stringency washes of SSC, and dehydrated in a graded ethanol series. Slices and radioactive standards were exposed for one wk to an autoradiographic film (Biomax MS-1 Kodak; Sigma). Standards were included in each cassette to verify that the measured values of optical densities were in the linear response range of the film. Densitometric analysis of hybridization signals was performed with a computerized analysis system (Biocom RAG200, Les Ulis, France). The optical density of specific signal was calculated by subtracting the intensity of staining background area (defined as a circle of 100 μ m diameter) measured in the anterior hypothalamic area above the SCN from that of a circle of 100 μ m diameter measured in the right and left SCN. Measures were made on three consecutive slices in the rostrocaudal middle of the SCN and averaged for a given brain. Data were expressed as relative optical density values.

Light-induced behavioral phase shifts

Experiment 3 was designed to test the ability of timed calorie restriction to modulate light-induced phase shifts of locomotor activity rhythm. Mice were exposed to 3 wks of food restriction under LD conditions and then transferred to DD, as described for Experiment 1 (hypocaloric-fed vs. fed *ad libitum*), except that on the first day of DD, animals were placed for 30 min in a white chamber delivering a light pulse of 100 lux at 3 h intervals starting at projected ZT 0 (5 hypocaloric-fed mice and 4 mice fed *ad libitum* per time point). Six

hypocaloric-fed and 6 mice fed *ad libitum* that were placed into a dark chamber (0 lux) for 30 min served as dark controls. Assessment of light-induced phase changes in the SCN-controlled nocturnal period of activity followed the method described above for determining possible behavioral phase changes in response to restricted feeding.

Responses to light of pineal melatonin and clock genes

In Experiment 4, mice were exposed to 3 wks of food restriction under LD conditions and then transferred to DD, as described for Experiment 1 (hypocaloric-fed vs. fed *ad libitum*). On the first day of DD, food was provided at the usual time and then subgroups of animals were exposed to a light pulse at projected ZT 0, 3, 6, 9, 12, 15, 18 or 21. Light-exposed mice (4 hypocaloric-fed and 4 fed *ad libitum* per time point) were sacrificed in darkness 60 min after the beginning of 30 min light exposure, and dark controls (4 hypocaloric-fed and 3 fed *ad libitum* per time point) were killed at the same time in darkness. After isoflurane anesthesia and decapitation, brains and pineal glands were removed and stored at -80°C. Pineal melatonin content was determined by radioimmunoassay, as previously described (Vivien-Roels *et al.*, 1999). *In situ* hybridization with riboprobes for *Per1* and *Per2* was performed as above on hypothalamic slices. Plasmids were kindly provided by Dr. H. Okamura (University of Kobe).

Statistical analysis

Data are presented as means \pm SEM. Analyses of variance, with or without repeated measures, were followed by post-hoc comparisons with the Student-Newman-Keuls test. For a given feeding condition, the daily patterns of gene expression and pineal melatonin were fitted by a non-linear least-squares regression (SigmaPlot software, Jandel Scientific, Chicago, USA) to determine the basal level, the mean peak level above basal, the phase and duration of the peak (i.e., the interval between half maximal values either side of the peak) using the following logistic equation:

$$y = y_0 + (y_{\max} / ((1 + \exp(\text{slope1} \times (\text{phi} - x))) \times (1 + \exp(\text{slope2} \times (x - \text{phi} - d))))))$$

where y is the level of mRNA, y_0 is the basal level, y_{\max} is the mean peak level above basal, slope1 is the ascending slope, phi is the time of half increase, slope2 is the descending slope, and d is the duration of the peak (i.e., the delay between times of half amplitude on increase

and decrease). The slopes were determined from regression on a first trial run, and then set at constant values throughout. The effects of the feeding conditions (*ad libitum* feeding vs. normocaloric diet, *ad libitum* feeding vs. hypocaloric diet, and normocaloric vs. hypocaloric diet) were then assessed by a variance-covariance analysis in which the following parameters were introduced stepwise according to F-to-enter: Δ_{y0} = difference in basal level, $\Delta_{y_{max}}$ = difference in amplitude, Δ_{ϕ} = difference in phase (delay or advance of time of half increase), and Δ_d = difference in peak duration. When all parameters had been added, the final equation was:

$$y = (y_0 + \Delta_{y0}) + ((y_{max} + \Delta_{y_{max}}) / ((1 + \exp(\text{slope1} \times (\phi + \Delta_{\phi} - x))) \times (1 + \exp(\text{slope2} \times (x - \phi - \Delta_{\phi} - d - \Delta_d))))))$$

The analysis gave the calculated values of Δ_{y0} , $\Delta_{y_{max}}$, Δ_{ϕ} and Δ_d , and the associated probabilities. Any effect was considered statistically significant if $P \leq 0.05$.

Results

Changes in daily pattern of wheel-running activity

At a behavioral level, hypocaloric-fed mice showed changes in their daily pattern of locomotor activity, characterized by a robust bout of activity prior to the time of feeding and an alteration of the phase-lock of the nocturnal activity to dark onset (Fig. 21). Normocaloric-fed mice expressed a small bout of activity prior to the time of feeding and no apparent change in the timing of nocturnal activity (Fig. 21). Phase changes of the SCN-controlled rhythm of locomotor activity were assessed during *ad libitum* refeeding in DD. While both control mice fed *ad libitum* and mice fed with a normocaloric diet showed

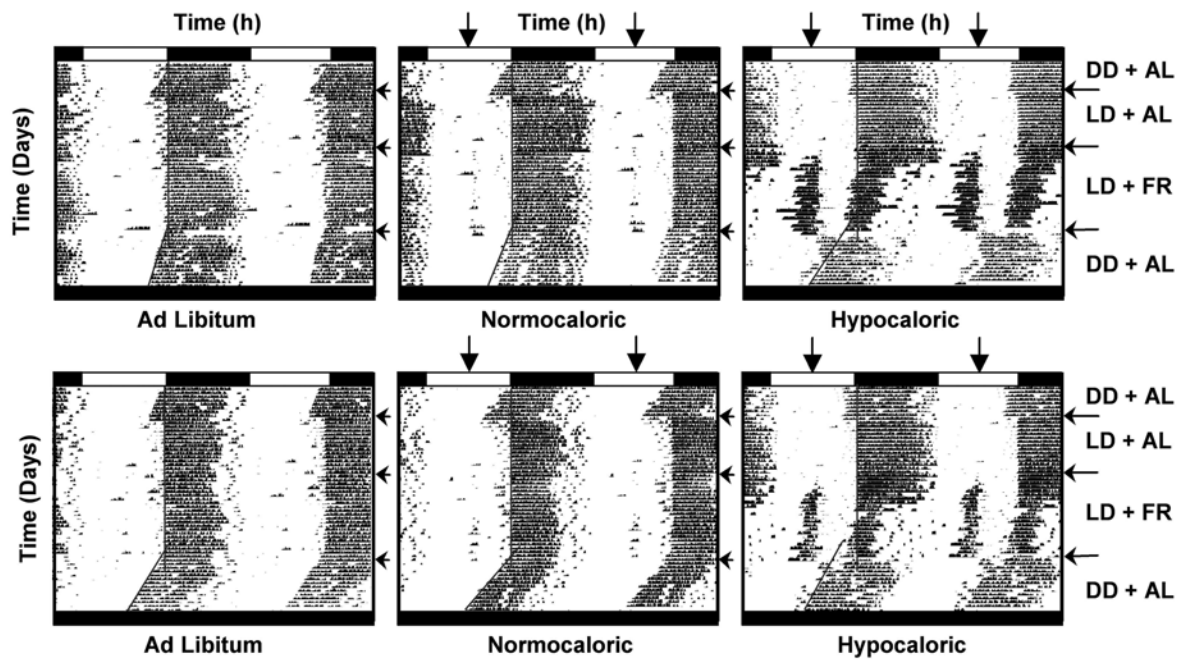

Figure 21. Daily wheel-running activity in 2 ad lib-fed mice (left panels), 2 normocaloric-fed mice (middle panels) and 2 hypocaloric-fed mice (right panels). First period (1 wk) in constant darkness and ad libitum feeding (DD + AL) ; second period (2 wks) in light-dark cycle and ad libitum feeding (LD + AL) ; third period (3 wks) in light-dark cycle and food restriction (LD + FR), and fourth period (2 wks) in constant darkness and ad libitum feeding (DD + AL). Successive 24 h periods are double-plotted (48 h horizontal time scale). Nighttime when mice were housed under light-dark conditions is indicated by black bar on upper abscissa. Time of feeding during food restriction is indicated by a vertical arrow 6 h after lights on. AL, ad libitum feeding; DD, constant darkness; FR, food restriction; LD, light-dark cycle.

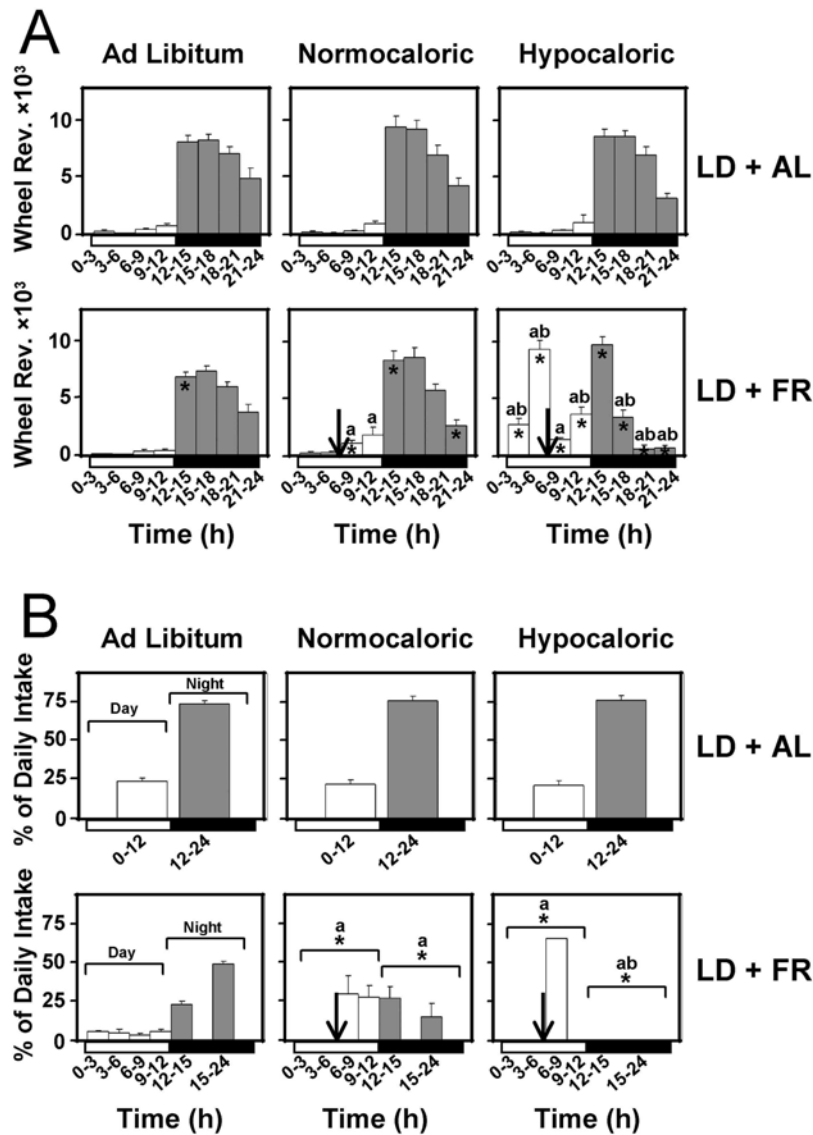

Figure 22. A. Daily pattern of wheel-running activity during the last 8 days in light-dark cycle and ad libitum feeding (LD + AL, upper panels) and during the last 8 days in light-dark cycle and food restriction (LD + FR, lower panels). Wheel-running activity is presented as cumulated wheel revolutions (rev.) during 3 h intervals. *: $P < 0.05$ in bouts of activity for a given nutritional status between LD + AL and LD + FR; a and b: $P < 0.05$ in activity bouts in hypocaloric-fed or normocaloric-fed mice compared to ad lib-fed mice, and in hypocaloric-fed vs. normocaloric-fed mice, respectively. Nighttime is indicated by a black bar on abscissa. Time of hypocaloric and normocaloric feeding is indicated by a vertical arrow 6 h after lights on. Means \pm SEM ($n = 8$ per feeding condition).

B. Daily pattern of food intake (expressed as % daily intake during baseline) in light-dark cycle and ad libitum feeding (LD + AL, upper panels) and during the 3rd wk of food restriction under a light-dark cycle (LD + FR, lower panels). Food intake during baseline

was determined over 24 h at two 12 h intervals, daytime and nighttime. Food intake during food restriction was measured over 24 h, every 3-h intervals from ZT 0 to ZT 15 and during a 9-h interval from ZT 15 to ZT 24. During food restriction, the normocaloric-fed group received 100% of daily food intake (i.e., 5.4 g) 6 h after the onset of light and they ate 60 and 40 % of this diet during the afternoon (i.e., from ZT 6 to ZT 12) and the night (i.e., from ZT 12 to ZT 24), respectively. The hypocaloric-fed group was given only 66% of baseline food intake (i.e., 3.6 g) at ZT 6. This hypocaloric diet was eaten between ZT 6 and ZT 9. Control mice had a free access to food over the experiment. Statistical analysis of food intake was performed on the cumulated intake during daytime and nighttime. *, $P < 0.05$ in diurnal or nocturnal food intake for a given nutritional status between LD + AL and LD + FR; a and b, $P < 0.05$ in diurnal or nocturnal food intake in hypocaloric-fed or normocaloric-fed mice compared to ad lib-fed mice, and in hypocaloric-fed vs. normocaloric-fed mice, respectively. Nighttime is indicated by a black bar on abscissa. Time of hypocaloric and normocaloric feeding is indicated by a vertical arrow 6 h after lights on. Means \pm SEM ($n = 6$ per feeding condition).

very small behavioral phase shifts (0.1 ± 0.1 and 0.6 ± 0.2 h, respectively), the phase of the activity onset was advanced by 3.6 ± 0.4 h in hypocaloric-fed mice ($P < 0.001$; Fig. 21).

The endogenous period in DD was not significantly modified by the treatment (baseline vs. after food restriction, $\tau = 23.8 \pm 0.04$ vs. 23.9 ± 0.05 h, respectively; $P > 0.05$), nor by the feeding condition (hypocaloric feeding, normocaloric feeding, and *ad libitum* feeding, $\tau = 23.8 \pm 0.05$, 23.8 ± 0.04 and 23.9 ± 0.07 h, respectively; $P > 0.05$; Fig. 21), and the treatment \times feeding condition interaction was not significant ($P > 0.05$).

During baseline, all mice show a large increase of wheel-running activity at night (Fig. 22A). The average total number of wheel revolutions during days of baseline was similar between the 3 nutritional groups (28426 ± 2103 , 30930 ± 2643 , and 29377 ± 2282 wheel revolutions in hypocaloric-, normocaloric-fed mice, and control mice fed *ad libitum*, respectively; $P > 0.1$). In response to food restriction, the average total number of wheel revolutions was not significantly modified by the nutritional status (31449 ± 2639 , 28648 ± 2506 , and 25216 ± 1552 wheel revolutions in hypocaloric-fed, normocaloric-fed, and control ad lib-fed mice, respectively; $P > 0.1$). However, both hypocaloric- and normocaloric-fed mice

displayed changes in their day-night pattern of activity compared to their activity pattern during baseline and to the pattern of activity in control mice fed *ad libitum*. The changes of activity pattern were more marked in hypocaloric- than in normocaloric-fed mice (Fig. 21, 22A). During the 6 h interval before the time of providing food to normocaloric- and hypocaloric-fed mice (i.e., from ZT 0 to ZT 6), the so-called food-anticipatory bout of activity was much larger in the latter group. During the two 3 h intervals following mealtime (i.e., from ZT 6 to ZT 12), both groups of mice displayed a higher level of locomotor activity than that performed at the same time by control mice. During the first 3 h nocturnal interval (ZT 12-15), locomotor activity was slightly decreased in normocaloric- and *ad lib*-fed mice, while it was increased in hypocaloric-fed mice compared to respective baseline values. In the last 3 h nocturnal interval (ZT 21-24), the level of wheel-running activity was significantly reduced in normocaloric-fed mice and, to a larger extent, in hypocaloric-fed mice (Fig. 22A).

Changes in day-night pattern of food intake, body mass and 24 h blood glucose

Daytime and nighttime food intake was modified significantly by time (baseline vs. food restriction; $P < 0.001$) and feeding condition (hypocaloric feeding, normocaloric feeding, and *ad libitum* feeding; $P < 0.05$). Moreover, the time \times feeding condition interaction was significant ($P < 0.001$). During baseline, all mice ate 25 and 75% of their spontaneous daily food intake during daytime and nighttime, respectively ($P > 0.1$; Fig. 22B). In response to food restriction, hypocaloric-fed mice ate their diet (66% of baseline intake) within the first 3 h interval after food was provided (i.e., between ZT 6-ZT 9). Normocaloric feeding led to a progressive change in the day/night ratio of food intake. During the 3rd wk of food restriction, daytime food intake in normocaloric-fed mice ($61 \pm 11\%$ of daily intake) was larger than that of *ad lib*-fed controls ($23 \pm 2\%$ of daily intake) and not different from that of hypocaloric-fed mice ($66 \pm 0\%$ of baseline intake; Fig. 22B). Nocturnal food intake was lower in normocaloric-fed mice ($39 \pm 11\%$ of daily intake) than in *ad lib*-fed controls ($77 \pm 2\%$ of daily intake; Fig. 22B).

Body mass was altered significantly by feeding condition (hypocaloric feeding, normocaloric feeding, and *ad libitum* feeding; $P < 0.001$) and the 3 wks of food restriction ($P < 0.001$; Fig. 23A). Body mass decreased only in mice fed with hypocaloric diet (after an initial loss during the 1st and 2nd wk, amounting -13 ± 2 and $-20 \pm 1\%$ of body mass

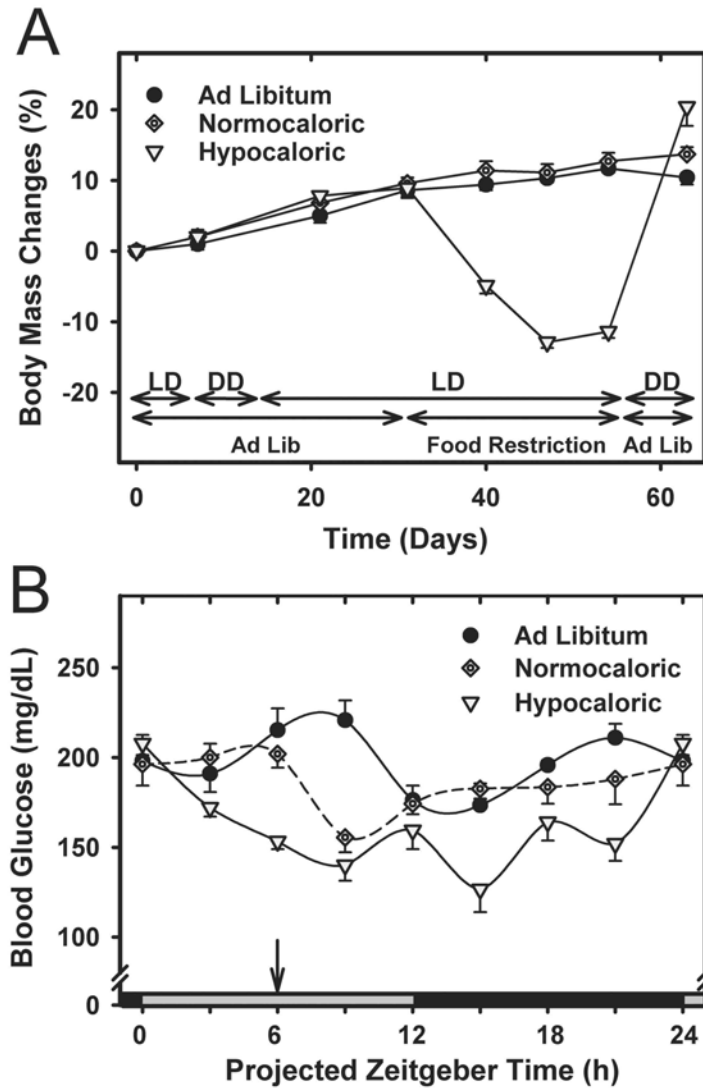

Figure 23. A. Changes in body mass (expressed as % of initial body mass at day 0) in hypocaloric-fed, normocaloric-fed and ad lib-fed mice. DD, constant darkness; LD, light-dark cycle.

B. Daily changes of blood glucose in hypocaloric-fed, normocaloric-fed and ad lib-fed mice. Projected zeitgeber time (pZT) 0 and pZT 12 are defined respectively as the projected times of lights on and lights off in the previous lighting cycle. Data for pZT 0 are double-plotted at pZT 24. Time of hypocaloric and normocaloric feeding 6 h after lights on is indicated by a vertical arrow.

measured at the end of baseline period, respectively, it remained stable at $-19 \pm 1\%$ during the 3rd wk of food restriction). During the same 3-wk period, mice fed *ad libitum* or with a normocaloric diet slightly increased body mass (3 ± 1 and $3 \pm 1\%$ of body mass measured at the end of baseline period, respectively). The loss of body mass in hypocaloric-fed mice was fully recovered by one wk of *ad libitum* refeeding (Fig. 23A).

Blood glucose was modified significantly by feeding condition ($P < 0.001$) and time of the day ($P < 0.001$). The decrease of daily blood glucose was much more marked in hypocaloric-fed mice (-19%) than in normocaloric-fed animals (-6%) compared to control values (159.4 ± 4.9 , 185.3 ± 4.3 and 197.7 ± 4.6 mg/dL, respectively; Fig. 23B).

Changes in expression of clock and clock-controlled genes

At a molecular level, the daily pattern of expression was assessed for four clock genes (i.e., *Per1*, *Per2*, *Cry2* and *Bmal1*) and one clock-controlled gene (i.e., *VP*) across feeding condition. The daily expression of the mRNA studied was very similar between normocaloric-fed mice and control animals fed *ad libitum*, except that the amplitude of *Per1* mRNA was slightly, but significantly higher in the SCN of normocaloric-fed mice ($P < 0.05$; Fig. 24, 25). By contrast, a number of differences in gene expression were detected in hypocaloric-fed mice compared to control individuals fed *ad libitum* or normocaloric-fed mice. With respect to expression of SCN clock genes, the daily oscillation of *Per1* in hypocaloric-fed was damped compared to that in *ad lib*-fed ($P < 0.05$) and normocaloric-fed mice ($P < 0.05$). SCN *Per1* oscillation in hypocaloric-fed mice was phase advanced by 1.4 ± 0.4 and 1.1 ± 0.4 h compared to that in *ad lib*-fed ($P = 0.001$) and normocaloric-fed mice ($P < 0.01$),

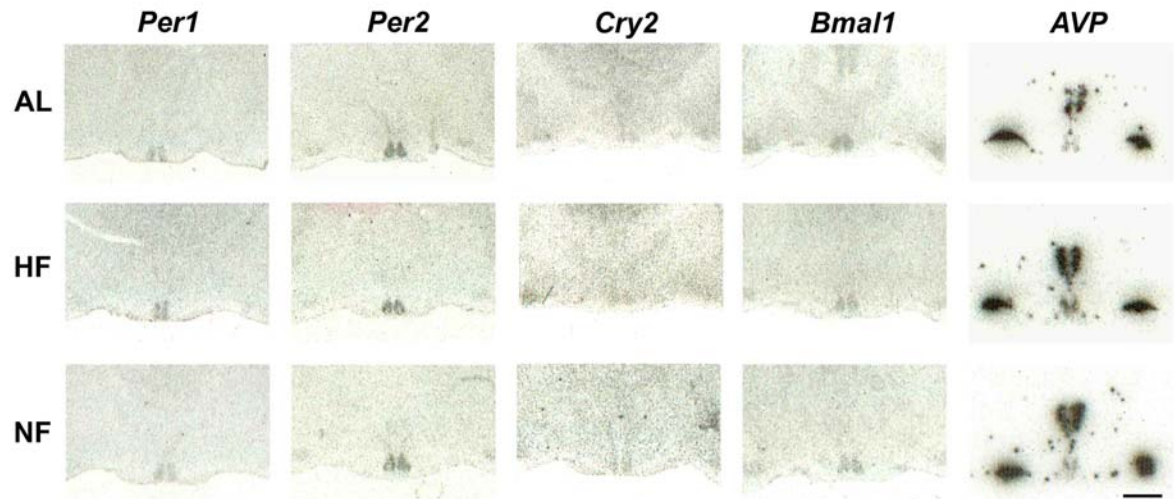

Figure 24. Expression of *Per1* at projected zeitgeber (pZT) 3, *Per2* at pZT 12, *Cry2* at pZT 6, *Bmal1* at pZT 18 and vasopressin (VP) at pZT 3 in the suprachiasmatic nuclei of ad lib-fed (AL, upper panels), hypocaloric-fed (HF, middle panels) and normocaloric-fed mice (NF, lower panels). Scale bar = 1 mm.

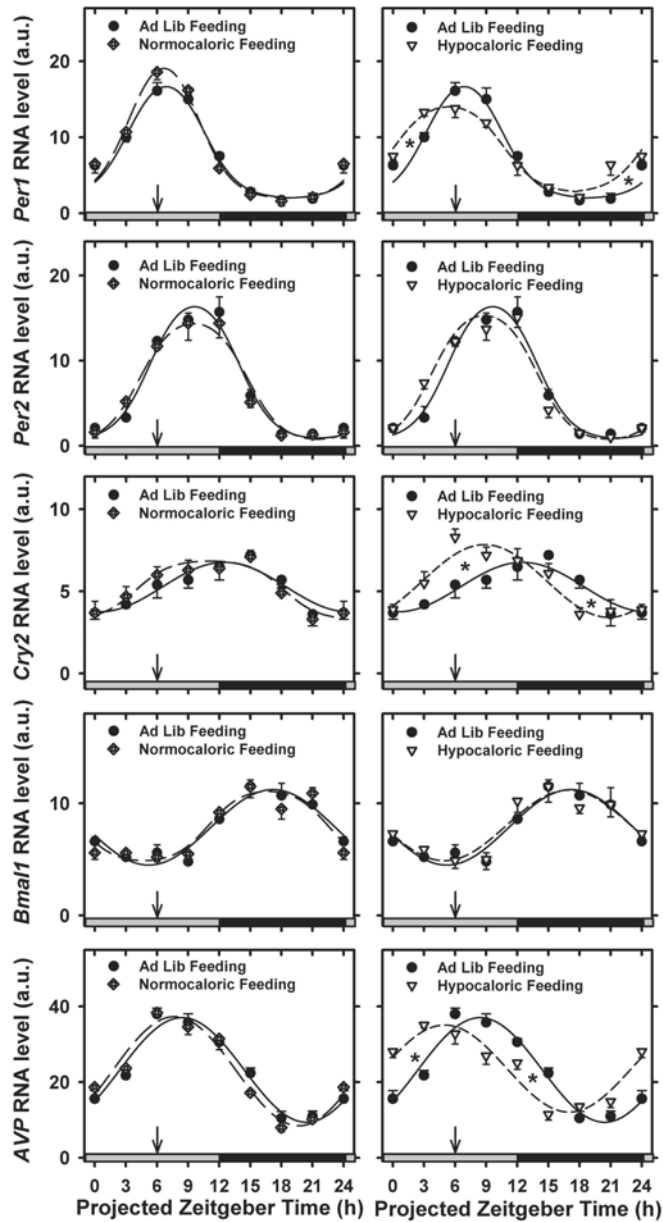

Figure 25. Daily profiles of *Per1*, *Per2*, *Cry2*, *Bmal1* and vasopressin (VP) mRNA levels in the SCN of ad lib-fed vs. normocaloric-fed mice (left column) and of ad lib-fed vs. hypocaloric-fed mice (right column) and respective fitted curves. Means \pm SEM ($n = 4$ per feeding condition at a given time point) and fitted curves. Stars indicate a significant phase shift between the 2 curves. Data for projected zeitgeber time (pZT) 0 are double-plotted at pZT 24. Nighttime is indicated by a black bar on abscissa. Time of hypocaloric and normocaloric feeding is indicated by a vertical arrow 6 h after lights on. a.u., arbitrary unit.

respectively. Daily oscillation of *Per2* in the SCN of hypocaloric-fed mice was slightly, but not significantly, phase advanced compared to ad lib-fed (0.6 ± 0.3 h ; $P=0.07$) and normocaloric-fed mice (0.3 ± 0.4 h ; $P>0.1$). Moreover, in addition to a higher amplitude ($P=0.04$) compared to ad lib-fed, but not to normocaloric-fed mice, the phase of *Cry2* mRNA was phase advanced by 3.3 ± 0.8 h in hypocaloric-fed vs. ad lib-fed mice ($P<0.001$) and by 2.3 ± 0.8 h in hypocaloric-fed vs. normocaloric-fed mice ($P<0.01$). By contrast, the daily profile of *Bmal1* was similar regardless of feeding condition (Fig. 24). Finally, the phase of the daily expression of SCN *VP* was phase advanced by 4.5 ± 0.5 h in hypocaloric-fed vs. ad lib-fed mice ($P<0.001$) and by 2.8 ± 0.5 h in hypocaloric-fed vs. normocaloric-fed mice ($P<0.001$).

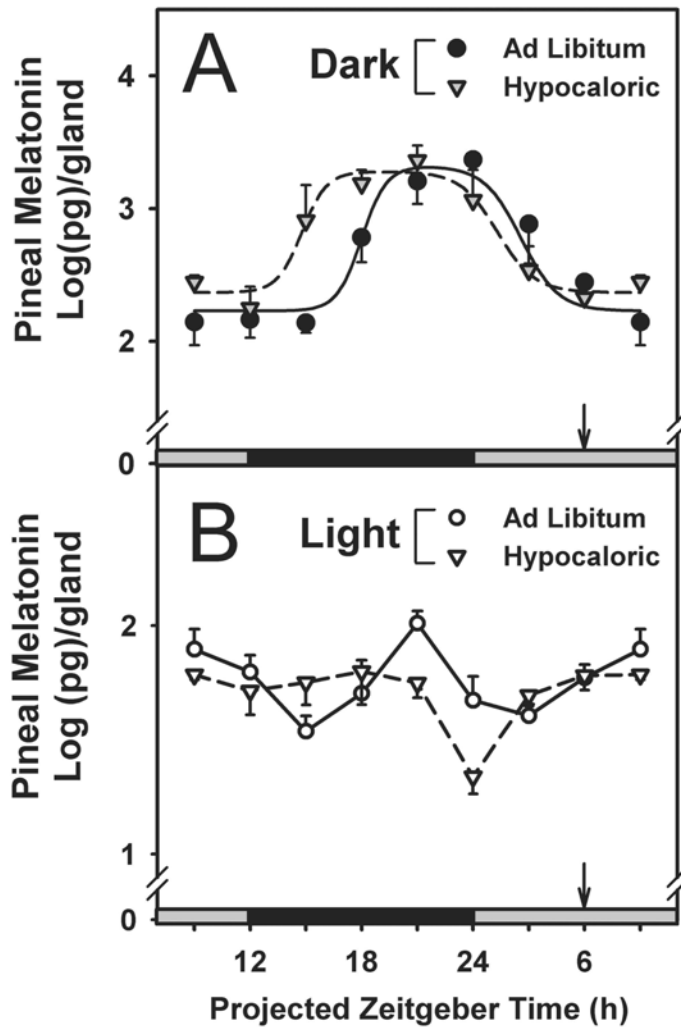

Figure 26. A. Daily rhythm of pineal melatonin in ad lib-fed (black circles; $n=3$ per time point) vs. hypocaloric-fed mice (open triangles; $n=4$) and respective fitted curves.

B. Light-induced suppression of plasma melatonin in ad lib-fed ($n=4$ per time point) vs. hypocaloric-fed mice ($n=4$). Time of hypocaloric feeding is indicated by a vertical arrow 6 h after lights on. Data for projected zeitgeber time 9 are double-plotted.

Changes in circadian rhythm and light-induced suppression of pineal melatonin

Logarithmic transformation of individual values of pineal melatonin was performed before comparisons to ensure homogeneity of residual variances. The daily rhythm of pineal melatonin synthesis was phase advanced in hypocaloric-fed compared to that of ad lib-fed mice ($P < 0.002$; Fig. 26). The magnitude of the phase advance was larger for the onset (i.e., 3.2 h) compared to the offset of melatonin synthesis (i.e., 1.3 h). Light-induced suppression of pineal melatonin assessed over the circadian cycle was not significantly modified by the nutritional status (hypocaloric diet vs. *ad libitum* food; $P > 0.1$, Fig. 26).

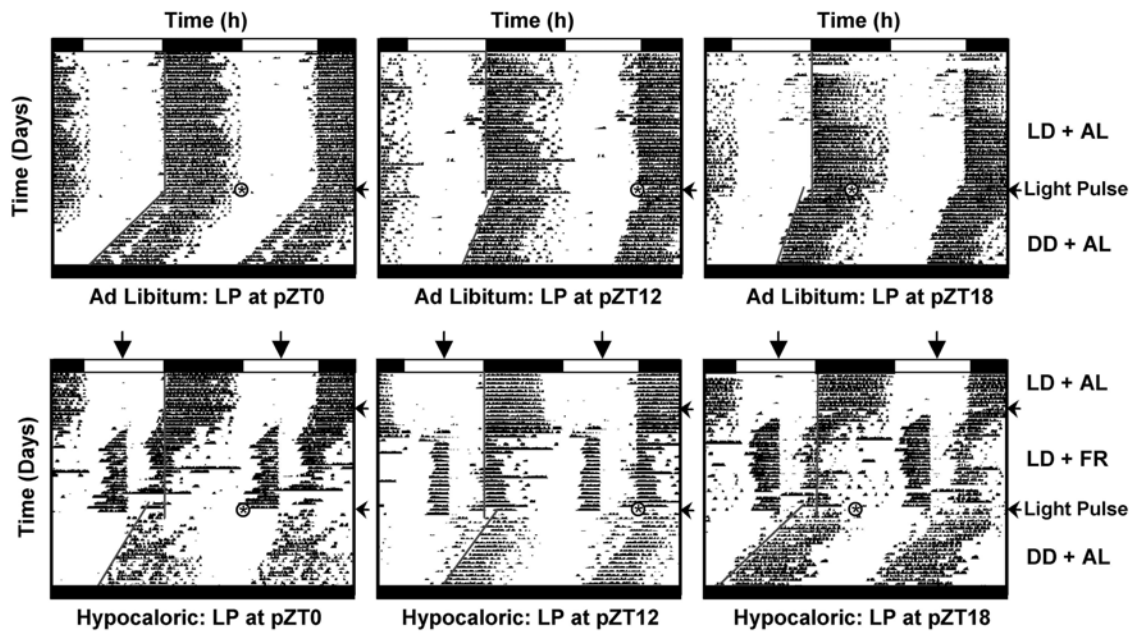

Figure 27. Daily wheel-running activity in 3 ad lib-fed mice (upper panels) and 3 hypocaloric-fed mice (lower panels) exposed to a light pulse (LP) at projected zeitgeber time (pZT) 0 (left panels), pZT 12 (middle panels) and pZT 18 (right panels). First period (2 wks) in light-dark cycle and ad libitum feeding (LD + AL); second period (3 wks) under a light-dark cycle with or without food restriction (LD + FR), and third period (2 wks) in constant darkness and ad libitum feeding (DD + AL) with a light pulse on the first day of constant darkness. Successive 24 h periods are double-plotted (48 h horizontal time scale). Nighttime when mice were housed under light-dark conditions is indicated by black bar on upper abscissa. Time of feeding during food restriction is indicated by a vertical arrow 6 h after lights on. Light pulse is indicated by circles. AL, ad libitum feeding; DD, constant darkness; FR, food restriction; LD, light-dark cycle.

Altered phase shift responses of locomotor activity rhythm to light

The amplitude and direction of light-induced phase shifts depended on the time of light exposure ($P < 0.0001$; Fig. 27, 28). The phase response curve to light in control C3H mice fed *ad libitum* was characterized by phase delaying and phase advancing regions in the early (pZT 12-15) and late (pZT 18-24) subjective night, respectively. During most of the subjective day (pZT 0-6), light exposure led to negligible behavioral phase shifts in control mice. Unexpectedly, compared to other phase response curves to light in mice (e.g., Schwartz and Zimmerman, 1990), phase advances were apparent at pZT 9 in C3H mice fed *ad libitum*. The shape of the phase response curve to light was dramatically changed in hypocaloric-fed mice ($P < 0.0001$; Fig. 27, 28). While light-induced phase delays were slightly reduced, phase advances in late night were more than twice in hypocaloric-fed mice compared to those in *ad lib*-fed animals. Moreover, large phase advances were still detectable in hypocaloric-fed mice exposed to a light pulse during the subjective day, a temporal window which corresponds to the “dead zone” of the phase response curve to light in control animals fed *ad libitum* (Fig. 27, 28).

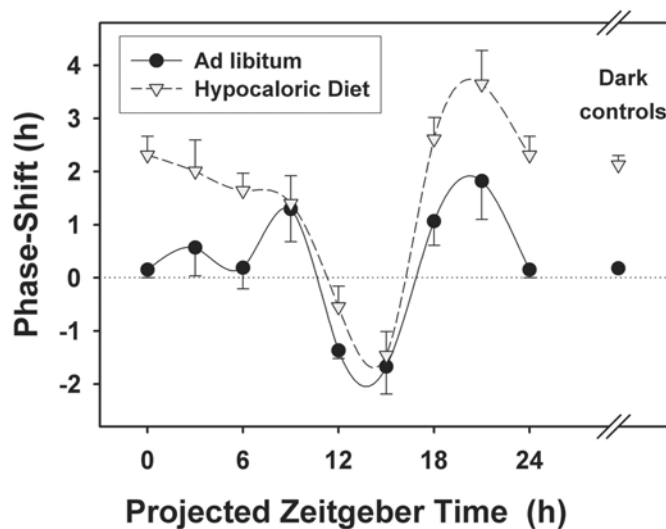

Figure 28. Phase response curve of locomotor activity rhythm to light exposure in *ad lib*-fed (black circles; $n=4$ per time point) and hypocaloric-fed mice (open triangles; $n=5$ per time point). Six *ad lib*-fed and 6 hypocaloric-fed mice not exposed to light served as “dark controls”. Data for projected zeitgeber time (pZT) 0 are double-plotted at pZT 24.

Altered responses of clock gene expression to light

In control animals fed *ad libitum*, light exposure during the subjective night in darkness led to a marked increase of *Per1* mRNA levels in the SCN ($P < 0.001$; Fig. 29, 30). Light induction of *Per1* in the SCN of hypocaloric-fed mice was lower in comparison with respective levels in ad-lib fed mice ($P < 0.001$; Fig. 29, 30). The reduction in light-exposed animals occurred not only during the night, but also during the day (Fig. 30, upper left panel), as confirmed with a non-significant feeding condition \times time interaction ($P > 0.5$). When compared to respective dark controls, the reduction of light induction of *Per1* in hypocaloric-fed mice was detected during the night (Fig. 30, upper right panel). Light induction of *Per2* was also altered in the SCN of hypocaloric-fed mice compared to that in control mice fed *ad libitum* (Fig. 29, 30). Contrary to *Per1*, there was an overall increased induction of *Per2* by light exposure in hypocaloric-fed mice ($P < 0.05$; Fig. 30, lower left panel). The small increase of *Per2* induction in the SCN of hypocaloric-fed mice was not time-dependent compared to ad lib fed mice also exposed to light, given that feeding condition \times time interaction was not significant ($P > 0.5$; Fig. 30, lower left panel). When compared to respective dark controls, a larger light induction of *Per2* was detected in the early night (Fig. 30, lower right panel).

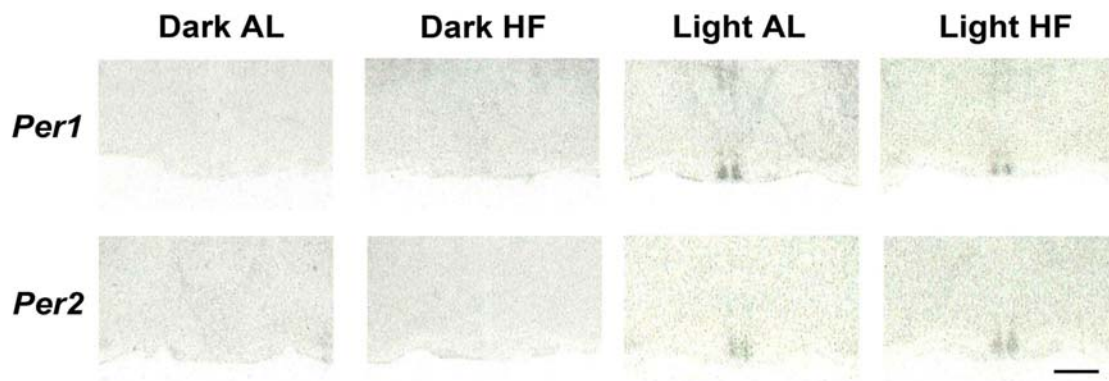

Figure 29. Expression of *Per1* and *Per2* in the suprachiasmatic nuclei of ad lib-fed (AL) and hypocaloric-fed mice (HF) exposed to a 1 h light pulse (right panels) at projected zeitgeber time (pZT) 18 (*Per1*) and at pZT 15 (*Per2*) or kept in dark at the same time points (left panels). Scale bar = 1 mm.

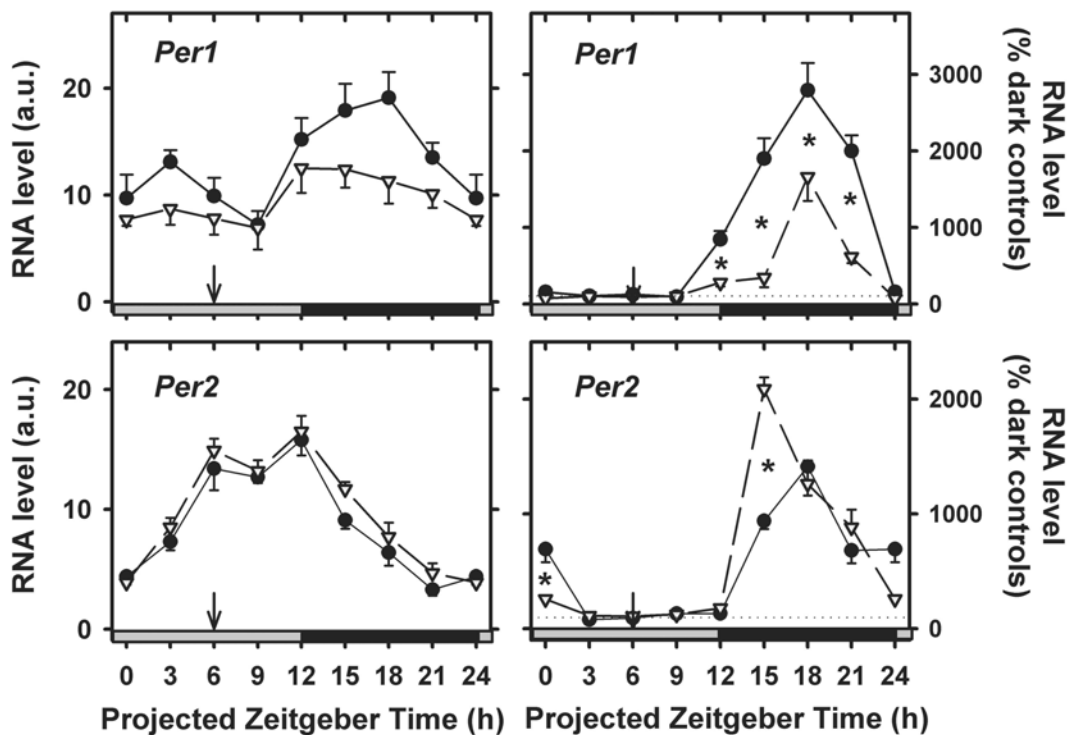

Figure 30. Altered light-induced expression of *Per1* and *Per2* in hypocaloric-fed mice (HF: open triangles) compared to control mice fed ad libitum (AL: black circles). Left panels: data are presented as absolute values in light-exposed animals ($n=4$ per time point per feeding condition). Right panels: data of light-exposed animals are presented as % of mRNA levels of mice not exposed to light (for each time point, 3 dark controls fed ad libitum and 4 dark controls previously fed with hypocaloric diet). Time of feeding during food restriction is indicated by a vertical arrow 6 h after lights on. a.u., arbitrary unit. Data for projected zeitgeber time (pZT) 0 are double-plotted at pZT 24. The effect of feeding condition (AL vs. HF) for *Per1* and *Per2* in light-exposed animals was significant at $P<0.001$ and $P<0.05$, respectively, while the interaction between feeding condition and time was not significant in both cases. * $P<0.05$ according to feeding conditions for a given time point.

Discussion

To our knowledge, this is the first study in which a synchronizer is shown to compete with entrainment to LD cycle, both at the behavioral and molecular levels. Contrary to daily normocaloric feeding, timed hypocaloric feeding modifies clock gene expression in the SCN and the phase of three outputs from the SCN (i.e., VP mRNA oscillation, daily rhythms of locomotor activity and pineal melatonin). Moreover, both temporal gating of light-induced phase shifts and light induction of *Per1* are deeply modified with daily hypocaloric feeding. These results thus demonstrate that repetitive food-related/metabolic cues interact with entrainment of the SCN to light.

No phase shifting effect of normocaloric feeding

Normocaloric feeding presented at midday did not modify the daily expression of clock genes in the SCN, or the timing of two circadian outputs, *VP* mRNA oscillation and locomotor activity rhythm. These variables were assessed in DD to prevent masking effects of light on clock-controlled parameters. Some changes, however, were detected on the daily pattern of wheel-running activity measured during normocaloric feeding under LD cycle. In keeping with the increased daytime food intake and its nocturnal decrease, locomotor activity was increased in early afternoon (i.e., after mealtime) and reduced in late night. The lack of significant shift of activity rhythm in DD suggests that the changes in activity distribution under LD cycle are not directly controlled by the SCN. Normocaloric feeding schedule also led to a post-prandial decrease of plasma glucose in late afternoon (Fig. 23). Even though the ratio of daytime/nighttime intake is then less drastic than that in daytime restricted feeding (that is, a food access strictly restricted to daytime) as used by others (Damiola *et al.*, 2000; Hara *et al.*, 2001; Stokkan *et al.*, 2001; Wakamatsu *et al.*, 2001), neither normocaloric feeding, nor daytime restricted feeding under LD cycle affect clock gene expression within the SCN.

Phase shifting effects of hypocaloric feeding

In contrast, timed hypocaloric feeding led to alterations in timing of the SCN clock: *Per1* and *Cry2* mRNA oscillations were phase advanced by 1.4 and 3.3 h, respectively, while *Per2* and *Bmal1* oscillations remained essentially unchanged. Moreover, oscillation of *VP* mRNA in the SCN, considered as a circadian output controlled by CLOCK/BMAL1 (Jin *et al.*, 1999), was phase advanced by 4.5 h. Finally, when animals were transferred to DD, the onset of the nocturnal locomotor activity was phase advanced by 3.6 h in hypocaloric-fed mice. The earlier nocturnal activity onset in calorie-restricted mice confirms previous findings (Challet *et al.*, 1998d; Holmes and Mistlberger, 2000; Sharma *et al.*, 2000).

The behavioral phase advance in calorie-restricted mice cannot be ascribed to a shortening of τ , because no changes were detected before vs. after food restriction. Nor can it be explained by transient hyperactivity it produces, although such bouts of activity during the subjective day can induce phase shifts of the SCN clock in nocturnal rodents (Mrosovsky *et al.*, 1989; Van Reeth and Turek, 1989; Marchant *et al.*, 1997). The food-anticipatory bout of activity that hypocaloric-fed rodents expressed before mealtime was initially considered to play a role in the behavioral phase advance. However, when food-anticipatory activity was prevented by daily immobilization, hypocaloric feeding was still capable of inducing a behavioral phase advance, indicating that food-anticipatory activity is not critical in mediating the phase shifting effects of a hypocaloric diet (Challet *et al.*, 1998d). Furthermore, because mice fed ad libitum and stressed on a daily basis showed no behavioral phase advance, a daily stress cannot account for the shifting effects of hypocaloric feeding (Challet *et al.*, 1998d).

The distribution of wheel-running during the active period affects the phase angle of photic synchronization (Mistlberger and Holmes, 2000). A higher amount of activity in early nocturnal period was associated with a 30 min advance in the phase angle of photic synchronization and a shortening of τ . Therefore, the slight increased running activity detected in hypocaloric-fed mice in the first 3 h nocturnal period (and/or the activity decrease in the late night) may participate in the phase advancing properties of timed hypocaloric feeding. However, hypocaloric feeding did not change τ . Moreover, an activity decrease in late night, although to a lesser extent, was also observed in normocaloric-fed mice that did not show significant behavioral phase advances. Taken together, these data indicate that if behavioral changes play a role in the phase advancing effects of hypocaloric feeding, they cannot be the only factors involved, suggesting that metabolic factors are in that case

predominant. Another finding supporting this metabolic hypothesis is that phase advances are induced whatever the time of the day (day or night) at which hypocaloric diet is given (Challet *et al.*, 1998d).

Serotonergic inputs from raphe nuclei and NPYergic projections from intergeniculate leaflets are neuronal pathways that have been shown to convey nonphotic signals to the SCN (e.g., Marchant *et al.*, 1997). These pathways and projections from the ventromedial hypothalamic nuclei may also participate in transmitting nonphotic cues associated with hypocaloric feeding signals to the SCN (Challet and Pevet, 2003).

Effects of hypocaloric feeding on SCN gene expression

While three outputs studied (i.e., *VP* expression, rhythms of locomotor activity and pineal melatonin) displayed significant phase advances, there were discrepancies between the phase-relationships of the clock genes studied in the SCN of hypocaloric-fed mice. Direct effects of food intake (i.e., masking effects) are unlikely to explain these various phase-relationships in the SCN of animals that were still fed on the day of sacrifice because food intake per se does not affect clock gene expression in the SCN (Damiola *et al.*, 2000; Stokkan *et al.*, 2001). Transient alterations between oscillations of different clock genes (Reddy *et al.*, 2002; Nagano *et al.*, 2003) and between clock gene oscillation and behavioral outputs have been already reported following rapid changes in LD cycle (Nagano *et al.*, 2003; Vansteensel *et al.*, 2003). Direct and conclusive implication of one or another clock gene in the control of behavioral outputs and the precise mechanisms leading to a complete and stable rephasing of clock genes still await clarification.

While *Per1* and *Cry2* mRNA levels were phase advanced, the daily oscillation of *Per2* and *Bmal1* in calorie-restricted mice matched closely that of control fed animals. When the photic zeitgeber is changed by lengthening or shortening the photoperiod, the phase and duration of *Per1* expression in the SCN are markedly modified accordingly, while *Bmal1* expression remains centered to the dark period with no change in duration. This difference observed both in hamsters (Tournier *et al.*, 2003) and sheep (Lincoln *et al.*, 2002) indicates that the duration of *Bmal1* oscillation is kept constant and its timing is phase-locked to the middle of the nighttime when parameters of the photic synchronizer (photoperiod) are modified. A differential effect between phasing of *Per1* and *Bmal1* is also observed here in the case of a competition between light and feeding/hypocaloric cues.

Because *VP* transcription is driven by CLOCK/BMAL1 heterodimers (Jin *et al.*, 1999), the lack of phase shift in *Bmal1* transcription concomitant with a 4 h phase advance in *VP* oscillation is puzzling. Calorie restriction may modify the timing of protein synthesis and/or phosphorylation, so that initiation of *VP* transcription occurs earlier than normally imposed by photic synchronization. Alternatively, if *Bmal1* oscillation is a phase marker of the SCN clock, the clock core may be considered in phase in both calorie-restricted and ad lib-fed mice, implying that the lag within the SCN concerns more specifically the temporal coupling of the clock core to the outputs.

Behavioral circadian responses to light

Light exposure in the early and late subjective night induces subsequent phase delays and advances, respectively (Daan and Pittendrigh, 1976). Our aim was to understand the behavioral phase advance expressed in rodents fed with a hypocaloric diet and exposed to LD cycle (Challet *et al.*, 1997c; 1998d). The shift may result from competing food and light synchronizers on the circadian molecular loops. Alternatively, considering that a restricted feeding does not provide temporal cues to the SCN, the hypometabolic state in response to chronic calorie restriction may lead to a decreased suprachiasmatic sensitivity to light resetting. Indeed, low glucose availability can reduce circadian phase shift responses to light (Challet *et al.*, 1999). Because plasma glucose is decreased in hypocaloric-fed mice (Fig. 25B), we expected reduced light-induced phase shifts with a hypocaloric feeding. Actually, light resetting properties after timed calorie-restriction are not decreased, but increased over the daily cycle. This finding thus suggests that decreased glucose availability cannot fully explain the data because, although light-induced phase delays were more or less reduced, light-induced phase advances were clearly increased. Moreover, there was no advance of the whole phase response curve to light.

Stress does not affect light resetting (Meerlo *et al.*, 1997; Challet *et al.*, 2001) and thus cannot account for the altered responses to light due to hypocaloric feeding. Moreover, hypocaloric feeding led to changes in daily wheel-running activity. Spontaneous or triggered wheel-running activity generally reduces (Ralph and Mrosovsky, 1992; Mistlberger and Antle, 1998) or leaves unchanged light-induced phase shifts (Mistlberger and Holmes, 2000). Thus, a behavioral modulation does not appear to readily explain the increased photic resetting in hypocaloric-fed mice. Nevertheless, the present data clearly indicate that the

phase advances induced by hypocaloric restricted feeding may in part be explained by altered photic gating of the clock.

Molecular circadian responses to light

Synchronization of the SCN to light is coupled with transcriptional mechanisms involving up-regulation of *Per* mRNA levels. Light exposure activates expression of *Per1* and *Per2* in the SCN during the night, when light also induces behavioral phase shifts (Albrecht *et al.*, 1997; Shigeyoshi *et al.*, 1997).

In hypocaloric-fed mice, there was a clear reduction in the induction of *Per1* transcription by light exposure while induction of *Per2* was slightly increased. This differential effect supports the hypothesis that both genes play different functions in the synchronization of the SCN clock (e.g., Albrecht *et al.*, 2001). For both genes, the effect in absolute values was not phase dependent but global over the daily cycle. As for the behavioral approach, these results suggest that timed calorie restriction leads to chronic (i.e., tonic) effects on the SCN clock.

Contrary to temporal restricted feeding, timed calorie restriction competes with entrainment to LD cycle, as evidenced by altered circadian oscillations of clock and clock-controlled genes in the SCN and circadian responses to light. A better understanding of how calorie restriction impacts on the temporal patterns of transcriptional activity in the SCN cells will be useful to characterize the control of energy metabolism on circadian rhythmicity and its entrainment to light.

Acknowledgements

The plasmids for synthesis of *rPer1*, *mPer2* and *mCry2* were generously donated by Dr. Hitoshi Okamura (Kobe University Graduate School of Medicine, Kobe, Japan). We are grateful to Christiane Calgari, Sylviane Gourmelen and Dominique Streicher for excellent technical assistance. We thank Dr. David Hazlerigg and Dr. Maria-Teresa Romero for constructive comments. The present study was funded in part by a "crédit exceptionnel pour jeunes équipes" from CNRS (E.C.).

II. Second part:

Localisation and subtype of the 5-HT receptor(s) involved in the photic-like effects of 5-HT agonists in the rat

Introduction

The results presented in the first part, raise the question of how the chronic metabolic cues can influence the light entrainment and more particularly which neuronal system could convey this information to the SCN?

The 5-HT afferences to the SCN could be implicated in the resetting effects of the timed caloric restriction since a lesion of these afferences with the specific 5-HT neurotoxin, 5,7-DHT, is able to block the phase advances of the locomotor activity and body temperature rhythm induced by this factor (Challet *et al.*, 1997e). Moreover, the link between food restriction and 5-HT is well documented. Acute and long-term application of food restriction as well as fasting have been shown to increase brain 5-HT metabolism. Indeed, the brain tryptophan concentration due to an increase of the uptake in blood, was increased in food restricted animals (Kantak *et al.*, 1978; Kohsaka *et al.*, 1980). Tryptophan being the precursor of the 5-HT, subsequent increase of 5-HT brain concentration has also been observed in rats after food restriction (Curzon *et al.*, 1972; Kantak *et al.*, 1978) and more precisely in the hypothalamus (Fuenmayor and Garcia, 1984; Schweiger *et al.*, 1989). Moreover, 5-HIAA, a metabolite of the 5-HT release, has also been demonstrated to increase in the whole brain (Curzon *et al.*, 1972; Kohsaka *et al.*, 1980; Schweiger *et al.*, 1989) and in the hypothalamus (Fuenmayor and Garcia, 1984) of food restricted rats. In addition, more recent studies demonstrated that the density of the 5-HT transporters in the forebrain of the food restricted rodents is lower compared to ad libitum fed animals (Zhou *et al.*, 1996; Huether *et al.*, 1997).

The 5-HT_{1B} receptors which regulate 5-HT release at a presynaptic level, show a decrease sensitivity specifically in the hypothalamus after a 4 weeks period of food restriction (Gur *et al.*, 2003). Altogether these data suggest an increase in the 5-HT synaptic concentration induced by food restriction.

In addition, 5-HT agonists in rats induce photic-like resetting effects of the locomotor activity rhythm with a phase delay when administered at the beginning of the subjective night and a phase advance when applied at the end of the subjective night and no effect when applied during the subjective day (Kennaway *et al.*, 1996; Kennaway and Moyer, 1998, 1999; Kohler *et al.*, 1999). Moreover, the expression of *c-Fos* and two clock genes are induced by 5-HT agonists during the night (Varcoe *et al.*, 2003). Considering that 5-HT availability is increased by food restriction and that 5-HT has photic-like effects in rats, this raises the hypothesis that in hypocaloric-fed animals the increased level of 5-HT could potentiate the synchronizing effects of light. This could explain the increase of light effects observed in hypocaloric-fed mice on locomotor activity rhythm at the end of the subjective night. We thus decided to study the neuronal mechanisms of the photic-like effects of 5-HT in rats to see how this transmitter could enhance the light input to the SCN. The results obtained are presented in the following two articles.

Article 2

*Involvement of the retinohypothalamic tract in the photic-like effects of the 5-HT
agonist quipazine in the rat*

Caroline Graff, Markus Kohler, Paul Pévet and Franziska Wollnik

Neuroscience (2005) 135 : 273-83.

Abstract

Light is the major synchronizer of the mammalian circadian pacemaker located in the suprachiasmatic nucleus (SCN). Photic information is perceived by the retina and conveyed to the SCN either directly by the retinohypothalamic tract (RHT) or indirectly by the intergeniculate leaflet (IGL) and the geniculohypothalamic tract (GHT). In addition, serotonin (5-HT) has been shown to affect the SCN by both direct and indirect 5-HT projections from the raphe nuclei. Indeed, systemic as well as local administrations of the 5-HT agonist quipazine in the region of the SCN mimic the effects of light on the circadian system of rats, i.e., they induce phase advances of the locomotor activity rhythm as well as c-FOS expression in the SCN during late subjective night. The aim of this study was to localize the site(s) of action mediating those effects. Phase shifts of the locomotor activity rhythm as well as c-FOS expression in the SCN after subcutaneous (s.c.) injection of quipazine (10 mg/kg) were assessed in Lewis rats, which had received either radio-frequency lesions of the intergeniculate leaflet (IGL) or infusions of the 5-HT neurotoxin 5,7-dihydroxytryptamine (5,7-DHT) into the SCN (25 µg/SCN) or bilateral enucleation. Lesions of IGL and 5-HT afferents to the SCN did not reduce the photic-like effects of quipazine, whereas bilateral enucleation and the subsequent degeneration of the retinohypothalamic tract (RHT) abolished both the phase shifting and the FOS-inducing effects of quipazine. The results indicate that photic-like effects of quipazine are mediated via the RHT.

Introduction

In mammals, the suprachiasmatic nuclei (SCN) of the hypothalamus contain the major pacemaker, which generates and regulates circadian rhythms (Moore, 1983; Morin, 1994). The most effective synchronizer of the circadian clock in the SCN is the light-dark (LD) cycle that resets the pacemaker every day (Pittendrigh and Daan, 1976). However, the circadian system can also be reset and entrained by various non-photoc stimuli such as access to a running wheel (Mrosovsky *et al.*, 1989) or arousal due to daily injections of triazolam, a benzodiazepine (Van Reeth and Turek, 1989).

According to the current state of knowledge (Moga and Moore, 1997; Morin, 1994), there are three major inputs to the SCN: (i) the retinohypothalamic tract (RHT), a direct

projection from the retina to the SCN (Moore and Lenn, 1972), which releases glutamate (Ebling, 1996) and pituitary adenylate cyclase-activating polypeptide (PACAP) (Hannibal *et al.*, 1997) as neurotransmitters, (ii) the geniculohypothalamic tract (GHT), an indirect projection originating in the retinorecipient intergeniculate leaflet (IGL) (Card and Moore, 1989), which releases neuropeptide Y (NPY) and γ -aminobutyric acid (GABA) (Moore and Speh, 1993) and (iii) a dense serotonergic input both directly from the median raphe nucleus (MRN) to the SCN and indirectly from the dorsal raphe nucleus (DRN) to the IGL (Azmitia and Segal, 1978; Moga and Moore, 1997; Hay-Schmidt *et al.*, 2003). Furthermore, a tract connecting the retina with the DRN has been demonstrated in rats (Kawano *et al.*, 1996). Although this pathway has not been detected in golden hamster (Morin, 1994), it indicates that, in the rat, photic information reaches the DRN and consequently may affect the circadian clock through the serotonergic inputs to the SCN and/or the IGL.

Data obtained in hamsters and rats indicate that the role of the 5-HT system is species dependent (Kohler *et al.*, 2000). In hamsters, for example, systemic injections of 5-HT agonists such as 8-hydroxy-2-(di-*n*-propylamino)tetralin (8-OH-DPAT, a 5-HT_{1A/7} agonist) induce phase advances during the subjective day (Tominaga *et al.*, 1992b; Cutrera *et al.*, 1996). Furthermore, phase advances induced by triazolam injections and arousal due to saline injections, but not novel-wheel running, are reduced by depletion or blockade of serotonergic transmission (Meyer-Bernstein and Morin, 1998). These results demonstrate the involvement of the 5-HT system in the phase resetting effects of non-photoc stimuli observed during subjective day. Moreover, during subjective night, 5-HT has been reported to reduce photic effects on the hamster circadian system, including light-induced phase shifts of locomotor activity rhythm (Rea *et al.*, 1994), increase in cellular firing (Ying and Rusak, 1994) and stimulation of c-FOS protein immunoreactivity (ir) in SCN cells (Selim *et al.*, 1993).

In rats, on the other hand, 5-HT enhances photic responses. Systemic injections of 5-HT agonists such as quipazine or the more specific 5-HT_{2C} agonists (\pm)-1-(4-iodo-2,5-dimethoxyphenyl)-2-aminopropane (DOI) and 1-(3-chlorophenyl)-piperazine HCl (mCPP) have been shown to mimic the phase shifting effects of light on the circadian rhythms of locomotor activity (Kohler *et al.*, 1999) and melatonin (Kennaway *et al.*, 1996; Kennaway and Moyer, 1998, 1999). Furthermore, it has been shown that similar to light, quipazine and other 5-HT agonists injected in the periphery or in the SCN region induce c-FOS expression in the ventrolateral area of the SCN during subjective night, but not during subjective day

(Moyer *et al.*, 1997; Kennaway and Moyer, 1998, 1999; Kalkowski *et al.*, 1999; Kohler *et al.*, 1999; Varcoe *et al.*, 2003).

However, in *in vitro* studies on rat SCN slices, no photic-like effects have been observed. On the contrary, non-photic effects of 5-HT agonists have been demonstrated (Prosser *et al.*, 1990, 1993). In addition, quipazine, *in vitro*, failed to induce *c-fos* mRNA during subjective night (Prosser *et al.*, 1994b). These differences between the *in vivo* and *in vitro* data open questions concerning the pathway(s) involved in the photic-like effects of quipazine and other 5-HT agonists.

The photic-like effects of quipazine and other 5-HT agonists could be due to a direct action on the SCN neurons through postsynaptic 5-HT receptors, the 5-HT_{2C} receptor being the most likely candidate (Kennaway *et al.*, 2001). An alternative explanation would be that 5-HT affects the SCN at a presynaptic level. Possible targets include 5-HT receptors located on fibers (either RHT, GHT or 5-HT fibers from raphe nuclei) ending on SCN cells. The main focus of this study was thus to solve this issue by analyzing the photic-like effects of quipazine (phase shifting effect and c-FOS protein expression) in animals bearing lesions of either the RHT, the GHT, or specific destruction of the serotonergic input to the SCN.

Materials and Methods

Animals

Male rats of the inbred strain LEW/Ztm (albino) were housed individually in plastic cages (35 x 55 x 15 cm) equipped with a running wheel (diameter 35 cm, width 10 cm) under standard laboratory conditions (LD 12:12, lights on at 07:00 h, 20 ± 1°C, 50 ± 5% relative humidity) with food and water ad libitum for at least 2 weeks before the start of the experiments. Running wheel revolutions were recorded by a computer and collected in 5-min bins. All experiments with animals were performed in accordance with European Communities Council Directive of November 24, 1986 (86/609/EEC) as well as in accordance with the German law. All efforts were made to minimize the number of animals used and any potential suffering.

Surgical procedures

Bilateral IGL lesions

Bilateral IGL lesions were performed on animals weighing 332 ± 4 g. Ten minutes prior to surgery the animals received an intraperitoneal (i.p.) injection of atropine sulfate (0.1 mg/kg, Wirtschaftsgenossenschaft Deutscher Tierärzte; Garbsen, Germany) in order to diminish the mucous pulmonary secretion and avoid severe hypoxemia. The animals were then anesthetized (100 mg/kg ketamine hydrochloride, CeVa Tiergesundheit GmbH, Düsseldorf, Germany, and 4 mg/kg xylazine, Bayer, Leverkusen, Germany, intramuscular: i.m.) and placed in a Kopf stereotaxic instrument with the incisor bar set at -3.5 mm below the interaural line (Challet *et al.*, 1996b). IGL lesions were made by applying a 500 KHz radio-frequency current for 1 min (first group of $n = 9$ animals) or 2 min (second group of $n = 7$ animals) through the tip (diameter = 0.25 mm) of a temperature-monitoring electrode (Radionics model RFG-4A Research RF, Radionics, Burlington, MA) with the temperature at the electrode tip set to 80°C. In the first group, bilateral IGL lesions were made at two rostro-caudal levels, i.e., 4.1 and 4.7 mm posterior to bregma, 4.4 mm lateral to the midline and 4.9 mm below the dura. In the second group an additional lesion was aimed at 4.7 mm posterior to bregma, 3.7 mm lateral to the midline and 5.5 mm below the dura. A similar procedure was used in 8 sham-operated rats, except that the electrode was lowered only to 2.9 mm below the dura and no current was passed through the electrode.

5-HT depletion

Lesions of the 5-HT terminals within the SCN were performed following the technique developed by Cutrera *et al.* (1994), on 9 animals weighing 261 ± 8 g. The animals received an i.p. injection of desmethylinipramine (20 mg/kg, Sigma, Steinheim, Germany) 30 min prior to surgery to protect catecholaminergic terminals (Björklund *et al.*, 1975) followed by an i.p. injection of atropine sulfate 20 min later. Surgery was conducted stereotaxically under deep anesthesia (100 mg/kg ketamine hydrochloride and 1 mg/kg diazepam, Ratiopharm GmbH & Co, Ulm, Germany) with the incisor bar set at +5 mm above the interaural line. Microinjections of the serotonin specific neurotoxin 5,7-dihydroxytryptamine creatinine sulphate (5,7-DHT, Sigma, Steinheim, Germany) or vehicle (0.5% ascorbic acid, Merck,

Rathway, NJ) were delivered bilaterally into the SCN (25 µg 5,7-DHT in 0.2 µl vehicle per side) via a 1 ml Hamilton syringe. Serotonergic lesions of the SCN were made with the syringe positioned at a 2° angle at two rostro-caudal levels: 2.0 mm and 2.4 mm anterior to bregma, 0.7 mm lateral to midline, and 8.9 mm ventral to dura. Microinjections were made over a 1 min period and the cannula was left in place for 5-10 min to reduce neurotoxin leakage into the needle tract. Sham-operated rats (n = 4) received bilateral microinjections of vehicle only.

Biocular enucleation

Five rats were subjected to bilateral enucleations under deep anesthesia (100 mg/kg ketamine hydrochloride and 1 mg/kg diazepam).

Experimental protocol

After post-surgical recovery, the animals were returned to their running-wheel cages and transferred to constant darkness (DD) for at least ten days before receiving the first injection. IGL-lesioned and 5-HT-lesioned animals first received an injection of quipazine (Sigma-Aldrich Chemie GmbH, Deisenhofen, Germany; 10 mg/kg subcutaneous: s.c.) and 3 weeks after, an injection of vehicle (saline). The last quipazine injection, 3 weeks after the saline injection, was followed by a transcardiac perfusion. A first group of enucleated and control animals received an injection of either quipazine or saline and were maintained at least 10 days in DD to analyze the locomotor activity rhythm. Another group of enucleated and control rats received at least 10 days after transfer to DD a quipazine injection followed by a transcardiac perfusion to analyse c-Fos expression. Using a darkroom light source (<0.5 lux, Kindermann, Berlin, Germany), all injections were performed at circadian time (CT) 22, CT 12 being defined as the onset of the active period. We chose CT 22 because phase shifts as well as c-FOS expression were highest at this circadian phase compared to other CTs (Kohler *et al.*, 1999).

Histological procedures, control of the lesions and immunohistochemical procedures

At the end of the experiment, the animals were deeply anesthetized 2 h after the last quipazine injection at CT 22 and transcardially perfused with 200 ml phosphate-buffered saline (0.1 M PBS, pH 7.4) containing 0.1% heparin (Roth, Karlsruhe, Germany) followed by 200 ml 4% paraformaldehyde in 0.1M PBS, pH 7.4. The brains were removed, post-fixed in the same fixative for 24 h and then cryoprotected in 30% sucrose in PBS for 3 days. The brains were cut on a freezing microtome and collected in 0.1M PBS containing 0.1% Triton X-100 (PBST). In order to check the completeness of the IGL lesions, 30 µm brain sections were cut through the SCN and the IGL. Alternate sections of the SCN were processed for immunohistological localization of NPY and c-FOS, sections of the IGL for NPY only. For the 5,7-DHT-treated animals, alternate SCN sections were processed for 5-HT and c-FOS immunohistochemistry. In the third group (bilateral enucleation), 35 µm SCN sections were processed for c-FOS immunohistochemistry only. Immunohistological localization of 5-HT, NPY and c-FOS was done using standard procedures. Briefly, free-floating sections were rinsed in PBST and then incubated in NPY primary antibody (Peninsula, San Carlos, CA, USA, 1:1000 in PBST), 5-HT primary antibody (Oncogene, San Diego, CA, USA, 1:20000) or c-FOS primary antibody (Calbiochem, Schwalbach, Germany, 1:10000) for 18 h at room temperature. Sections were then reacted using the Vectastatin ABC kit (Vector Laboratories, Burlingame, CA, USA) with diaminobenzidine as the chromogen.

To determine IGL lesion extent, NPY-ir cells were counted throughout the rostrocaudal extent of the IGL. 100% IGL lesions were defined as those in which NPY-ir cells were totally absent. Furthermore, the area of NPY-ir fibers within both SCN was analyzed in 10 alternating sections from the mid-caudal part of the SCN using a computerized image system (SoftImaging, Münster, Germany). First, an area of interest was defined by outlining the borders of each SCN. Then, a data filter and a threshold level were determined such that only stained fibers were detected. Finally, the mean area of NPY-ir fibers for each animal was calculated from measurements of 10 bilateral SCN sections.

To determine 5-HT lesion extent, the mean area of 5-HT-ir fibers within the SCN was quantified with the same method. 100% 5-HT lesions were defined as those in which 5-HT-ir fibers were totally absent from the SCN, while the average area of the sham-operated animals was defined as a 0% lesion. Extent of lesions was then calculated for each animal in reference to the average area of the 100% lesion animals.

The expression of c-FOS-ir was also determined using the computerized software system. In this case the mean area of c-FOS-ir was assessed within a pre-defined area of interest (400 x 260 μm^2) placed within the ventral subfields of 10 bilateral SCN sections.

Behavior analyses

Eye-fitted lines through the daily onsets (CT 12) of activity were drawn by two observers without knowledge of the treatment for the 10 days before and after treatment (saline or quipazine). The phase shifts were defined as the average difference between the two lines on the day after the injection. The endogenous period (τ) was determined on these 10 days before and after the treatment.

Statistics

Statistical comparisons between surgery and treatments were performed using a two-factor analysis of variance (ANOVA) with repeated measurement when different injections were performed in the same animal. In the case of significant main effects or interactions, the Tukey HSD test was used for post hoc comparison of means.

Results

Histology

IGL lesions

Complete lesions of the IGL included adjacent portions of the dorsal and ventral geniculate nuclei (DGL and VLG, respectively) and may have also damaged borders of hippocampus, fimbria, reticular thalamic nucleus, subgeniculate nucleus, peripeduncular nucleus, zona incerta and optic tract. Fig. 31 shows representative coronal sections of a sham-operated rat and an animal bearing complete bilateral lesion of the IGL, along with sections of the corresponding SCN to illustrate NPY-ir in the SCN. In sham-operated animals, there was extensive NPY-ir in the ventrolateral, retinorecipient area of the SCN as well as in the dorsomedial part of the middle and caudal SCN. In IGL-lesioned animals, lesion size was confirmed by the reduction or complete absence of NPY-ir fibers and terminals in the SCN. After quantification of NPY-ir in the SCN, lesioned animals were divided into two groups: (i) those with only partial IGL lesions ($n = 9$, $\leq 75\%$ of NPY-ir decrease): the “partially IGL-lesioned” group and (ii) those with almost complete IGL lesions ($n = 7$, $> 75\%$ of NPY-ir decrease): the “wholly IGL-lesioned” group. This last group contains two animals with complete IGL lesion (100% disappearance of the NPY-ir fibers), whose responses to quipazine (phase advance of the locomotor activity and c-Fos expression in the SCN) are very similar to other animals in this group.

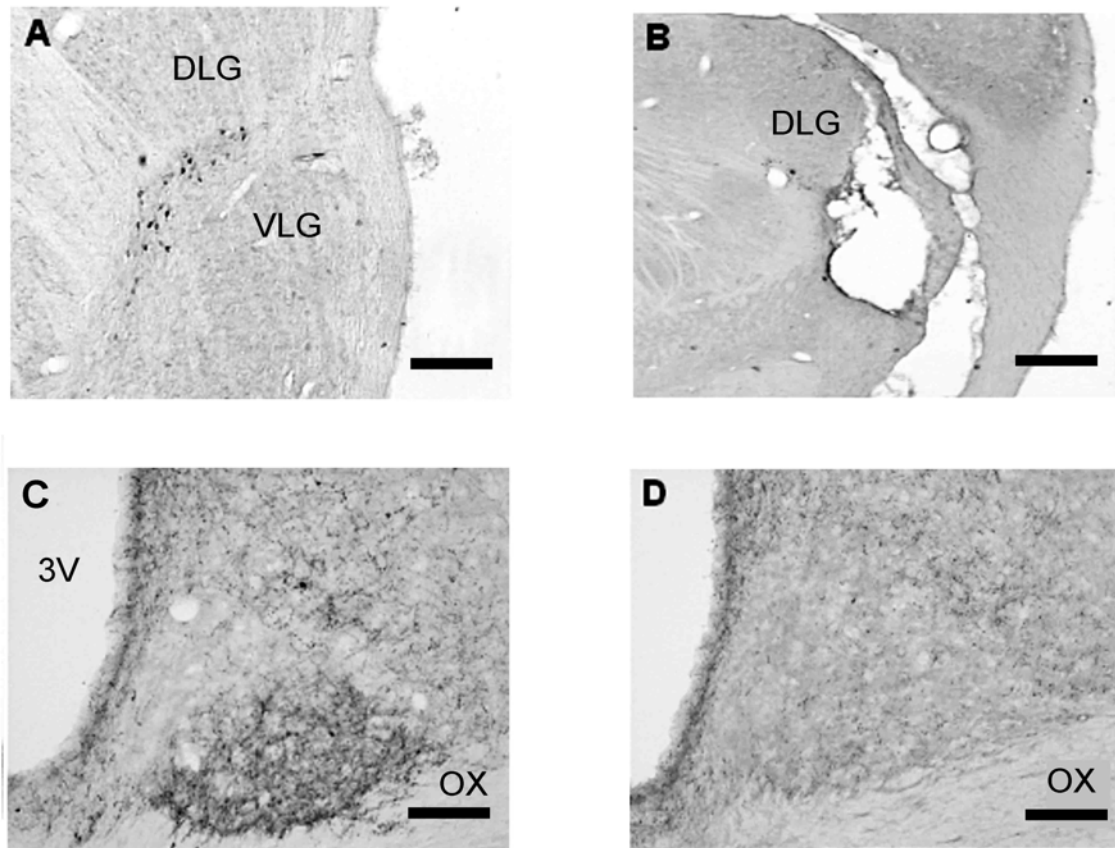

Figure 31. Representative photomicrographs showing NPY-ir cell in the IGL (A, B) and NPY-ir fibers in the SCN (C, D) of a sham-operated rat (A, C) and a rat with a complete IGL lesion (B, D). DLG = dorsal lateral geniculate, VLG = ventral lateral geniculate, OC = optic chiasm, 3V = third ventricle. Scale bar = 250 μm for A, 1 mm for B and 100 μm for C and D.

5-HT depletion

Microinjections of 5,7-DHT into the SCN significantly reduced 5-HT terminals within the SCN and surrounding areas as determined by immunohistological methods (Fig 32A,B). Sham-operated animals showed a dense plexus of 5-HT-ir fibers in the ventral part of the SCN (Fig. 32A), while the SCN of completely lesioned animals was devoid of essentially all 5-HT-ir fibers (Fig. 32B). There was some variability, because 5-HT fibers were not completely eliminated in all animals. After quantification of 5-HT-ir in the SCN, lesioned

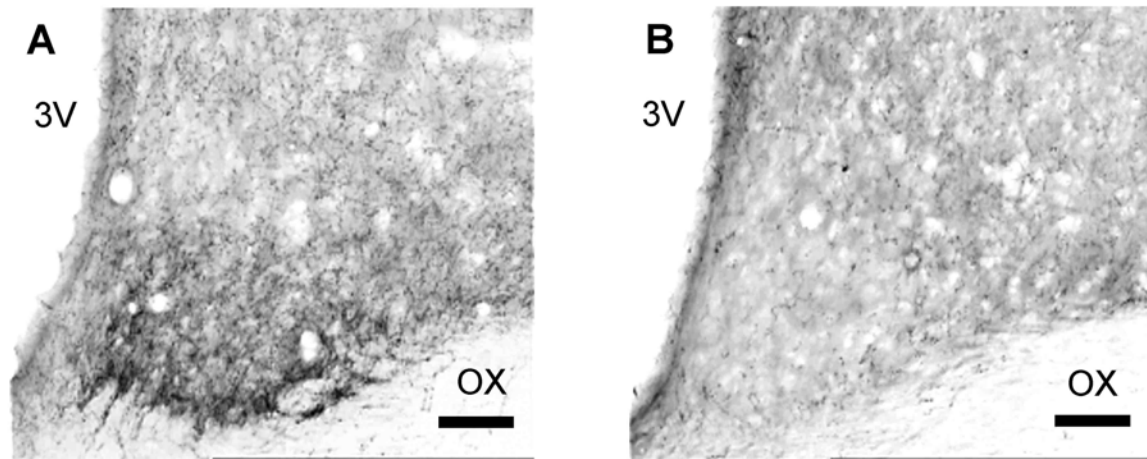

Figure 32. Representative photomicrographs showing 5-HT-ir fibers in the SCN of a sham-operated rat (A) and an animal bearing a complete neurotoxic lesion after 5,7-DHT injection into the SCN (B). OC = optic chiasm, 3V = third ventricle. Scale bar = 100 μ m.

animals were divided into two groups: (i) those with only partial 5-HT-lesions ($n = 4$, $\leq 75\%$ of 5-HT-ir decrease): the “partially 5-HT-lesioned” group and (ii) those with almost complete lesions ($n = 5$, $> 75\%$ of 5-HT-ir decrease): the “wholly 5-HT-lesioned” group. The attribution of these groups, based on the percentage of fibers remaining after the lesion, is justified by the results of Cutrera *et al.* (1994) in which the physiological responses were abolished after the degeneration of at least 80% of the 5-HT fibers. Moreover, this group contains four animals with complete 5-HT lesion (100% disappearance of the 5-HT-ir fibers), whose responses to quipazine (phase advance of the locomotor activity and c-FOS expression in the SCN) closely resemble to those of the other animals in this group.

Biocular enucleation

As confirmed by brain sections analyzed for c-FOS-ir in the SCN, bilateral enucleation produced a major degeneration of the optic nerve, including the optic chiasm and the RHT, as previously described (Moore and Lenn, 1972).

Circadian activity parameters

*I*GL lesions

Representative activity records for sham-operated and IGL-lesioned rats that received injections of quipazine or saline at CT 22 are shown in Fig. 33. Both IGL-lesioned and sham-operated rats showed large phase advances after quipazine treatment at CT 22, while saline injections had no effect. Fig. 34 shows mean phase shifts induced by quipazine and saline for sham-operated, “partially IGL-lesioned” (IGL-X_P) and “wholly IGL-lesioned” (IGL-X_W) animals. Two-way ANOVA revealed a significant effect of quipazine treatment ($F_{\text{injection}}(1,21) = 81.99, p < 0.001$). However, there were no significant differences either between groups (sham-operated vs “partially IGL-lesioned” vs “wholly IGL-lesioned”, $F_{\text{surgery}}(2,21) = 2.62, \text{n.s.}$) or between surgery and injection ($F_{\text{surgery/injection}}(2,21) = 0.14, \text{n.s.}$).

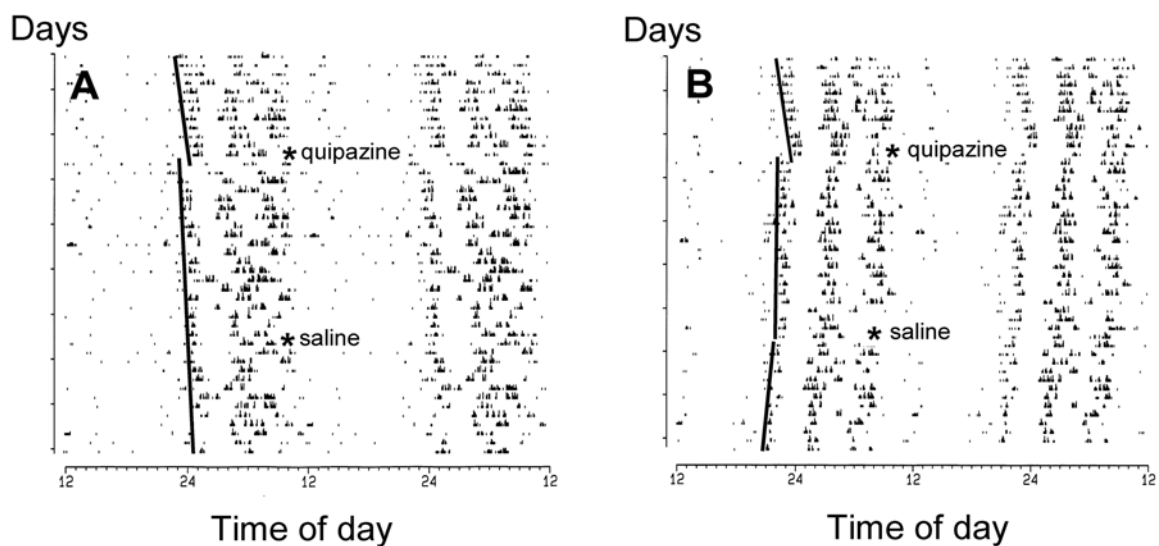

Figure 33. Double-plotted wheel-running activity records of sham-operated (A) and IGL-lesioned (B) rats before and after subcutaneous injections of quipazine (10 mg/kg) or saline at CT 22. Lines on the vertical axes denote 5-day intervals, whereas numbers on the horizontal axes denote time of day. To visualize phase shifts of the activity rhythm, eye-fitted lines are drawn through the onset of the activity rhythm before and after treatment. Treatment times (quipazine or saline) are indicated by asterisks.

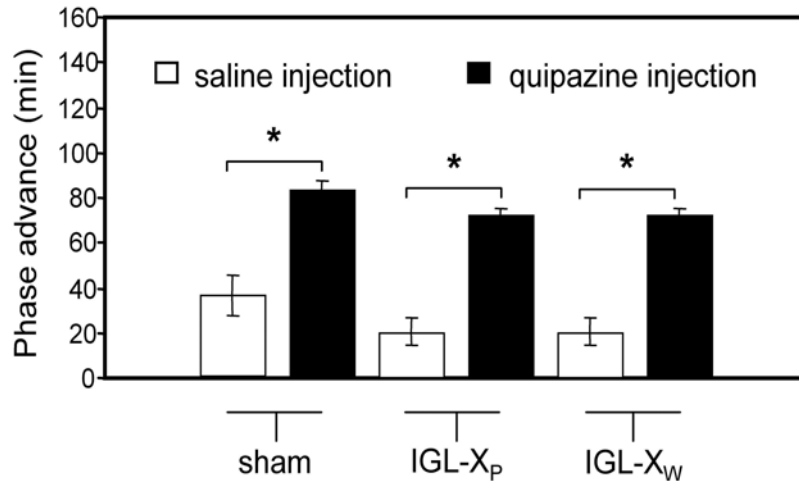

Figure 34. Comparison of phase shifts (means \pm SEM: standard error of mean) observed after saline (open bars) or quipazine (closed bars) injections at CT 22 in sham-operated ($n = 8$), “partially IGL-lesioned” (IGL-X_p; $n = 9$) and “wholly IGL-lesioned” (IGL-X_w; $n = 7$) animals. * $p < 0.001$, post-hoc Tukey HSD test.

In all groups, the differences between endogenous period (τ) of the locomotor activity before and after injections were calculated (before – after). One way ANOVA revealed a significant effect of the treatment (quipazine vs saline, $F_{\text{injection}}(1,21) = 6.64$, $p < 0.05$), a significant difference between groups (sham-operated vs “partially IGL-lesioned” vs “wholly IGL-lesioned”, $F_{\text{surgery}}(2,21) = 3.61$, $p < 0.05$) and between surgery and injection ($F_{\text{surgery/injection}}(2,21) = 12.46$, $p < 0.01$). However, τ differences never exceeded ± 0.11 h in sham-operated animals (after quipazine and saline injections, respectively 0.1 ± 0.03 h and -0.02 ± 0.02 h), “partially IGL-lesioned” animals (after quipazine and saline injections, respectively 0.1 ± 0.02 h and 0.08 ± 0.03 h) and “wholly IGL-lesioned” animals (after quipazine and saline, respectively 0.06 ± 0.02 h and 0.11 ± 0.02 h). Thus, those variations in τ cannot explain the advances of the locomotor activity onset observed in all groups after quipazine injection.

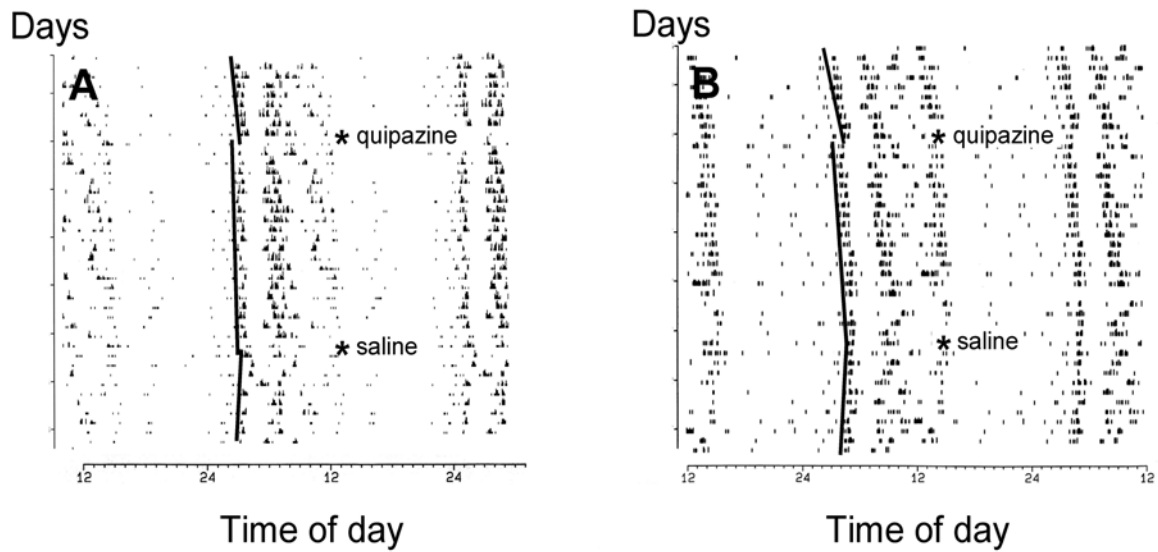

Figure 35. Double-plotted wheel-running activity records of sham-operated (A) and 5-HT-lesioned (B) rats before and after subcutaneous injections of quipazine (10 mg/kg) or saline at CT 22. Treatment times (quipazine or saline) are indicated by asterisks.

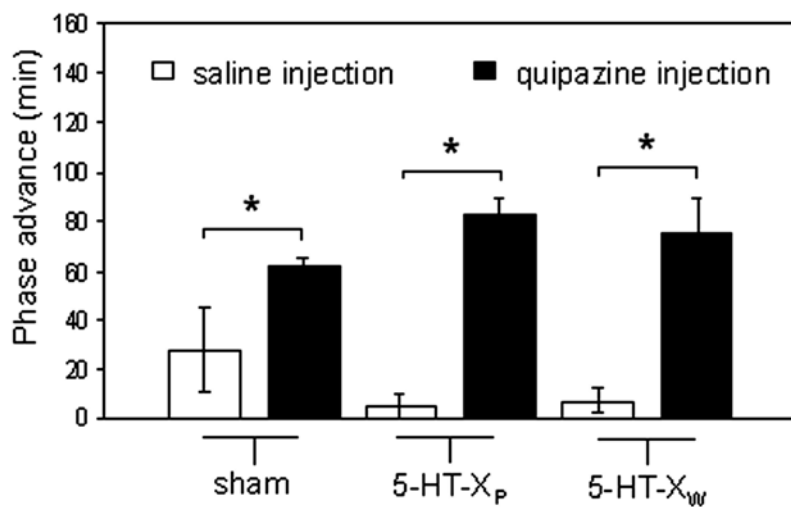

Figure 36. Comparison of phase shifts (means \pm SEM) observed after saline (open bars) or quipazine (closed bars) injections at CT 22 in sham-operated ($n = 4$), “partially 5-HT-lesioned” (5-HT-X_p; $n = 4$) and “wholly 5-HT-lesioned” (5-HT-X_w; $n = 5$) animals. * $p < 0.001$, post-hoc Tukey HSD test.

5-HT depletion

Representative activity records for sham-operated rats and 5-HT-lesioned rats that received injections of quipazine or saline at CT 22 are shown in Fig. 35. Quipazine induced large phase advances in both sham-operated and 5-HT-lesioned rats. Fig. 36 shows mean phase shifts induced by quipazine and saline treatment for sham-operated, “partially 5-HT-lesioned” (5HT-X_p) and “wholly 5-HT-lesioned” (5-HT-X_w) animals. Two-way ANOVA revealed a significant difference between quipazine and saline injections ($F_{\text{injection}}(1,10) = 54.85, p < 0.001$), whereas there were no differences between groups (sham-operated vs “partially 5-HT-lesioned” vs “wholly 5-HT-lesioned”, $F_{\text{surgery}}(2,10) = 0.09, \text{ n.s.}$) or between surgery and injections ($F_{\text{surgery/injection}}(2,10) = 2.67, \text{ n.s.}$).

In all groups, the differences between endogenous period (τ) of the locomotor activity before and after injections were calculated (before – after). One way ANOVA did not revealed a significant effect of the treatment (quipazine vs saline, $F_{\text{injection}}(1,10) = 1.58, \text{ n.s.}$), a significant difference between groups (sham-operated vs “partially 5-HT-lesioned” vs “wholly 5-HT-lesioned”, $F_{\text{surgery}}(2,10) = 0.33, \text{ n.s.}$) and between surgery and injection ($F_{\text{surgery/injection}}(2,10) = 0.14, \text{ n.s.}$). τ differences never exceeded ± 0.10 h in sham-operated animals (after quipazine and saline injections, respectively 0.07 ± 0.02 h and 0.06 ± 0.05 h), “partially 5-HT-lesioned” animals (after quipazine and saline injections, respectively 0.1 ± 0.04 h and 0.03 ± 0.06 h) and “wholly 5-HT-lesioned” animals (after quipazine and saline, respectively 0.08 ± 0.05 h and 0.01 ± 0.03 h).

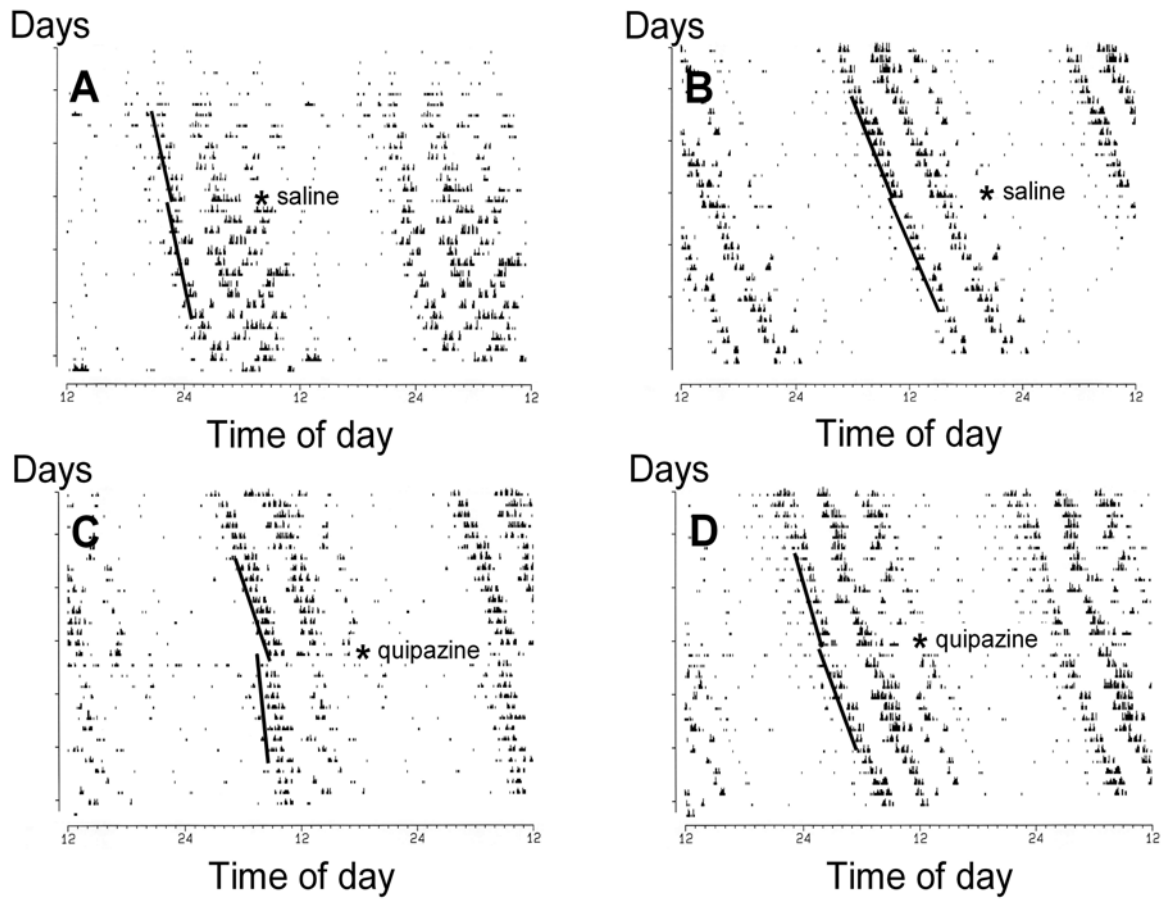

Figure 37. Double-plotted wheel-running activity records of control rats (A,C) and enucleated rats (B,D) before and after subcutaneous injections of saline (A,B) or quipazine (C,D) at CT 22. Treatment times (quipazine or saline) are indicated by asterisks.

Biocular enucleation

Representative activity records for intact and enucleated rats that received injections of quipazine or saline at CT 22 are shown in Fig. 37. Enucleated rats showed no phase shifts in response to quipazine treatment at CT 22 (Fig. 38). Two-way ANOVA revealed significant effects for bilateral enucleation ($F_{\text{surgery}}(1,25) = 41.68, p < 0.001$) and quipazine treatment ($F_{\text{injection}}(1,25) = 26.02, p < 0.001$) and a significant interaction among surgery and injection ($F_{\text{surgery/injection}}(1,25) = 24.18, p < 0.001$). The differences between endogenous period (τ) of the locomotor activity before and after injections were calculated (before – after). One way ANOVA revealed a significant effect of the surgery (intact vs enucleated animals, $F_{\text{surgery}}(1,25) = 8.12, p < 0.01$) but failed to reveal a significant effect of the treatment (quipazine vs saline, $F_{\text{injection}}(1,25) = 0.01, \text{n.s.}$) and a significant difference between surgery and injection ($F_{\text{surgery/injection}}(1,25) = 0.61, \text{n.s.}$). The advance of the locomotor activity onset after quipazine injection in intact rats cannot therefore be explained by an effect on the endogenous period.

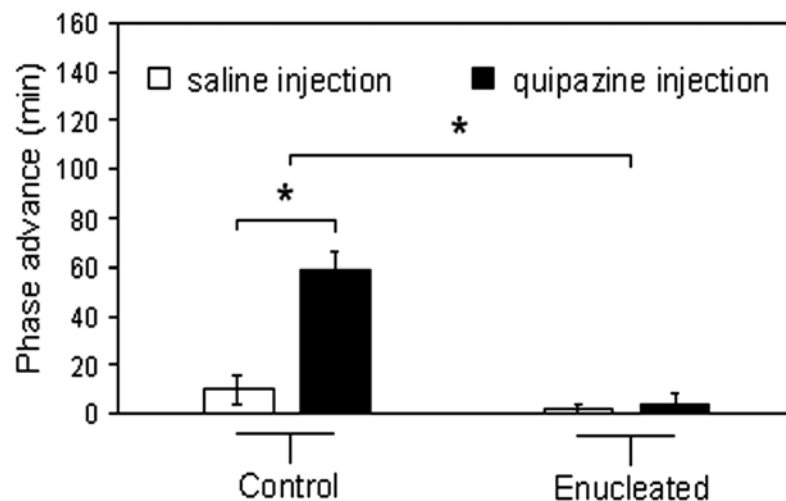

Figure 38. Comparison of phase shifts (means \pm SEM) observed after saline (open bars) or quipazine (closed bars) injections at CT 22 in control ($n = 7$) and enucleated rats. * $p < 0.001$, post-hoc Tukey HSD test.

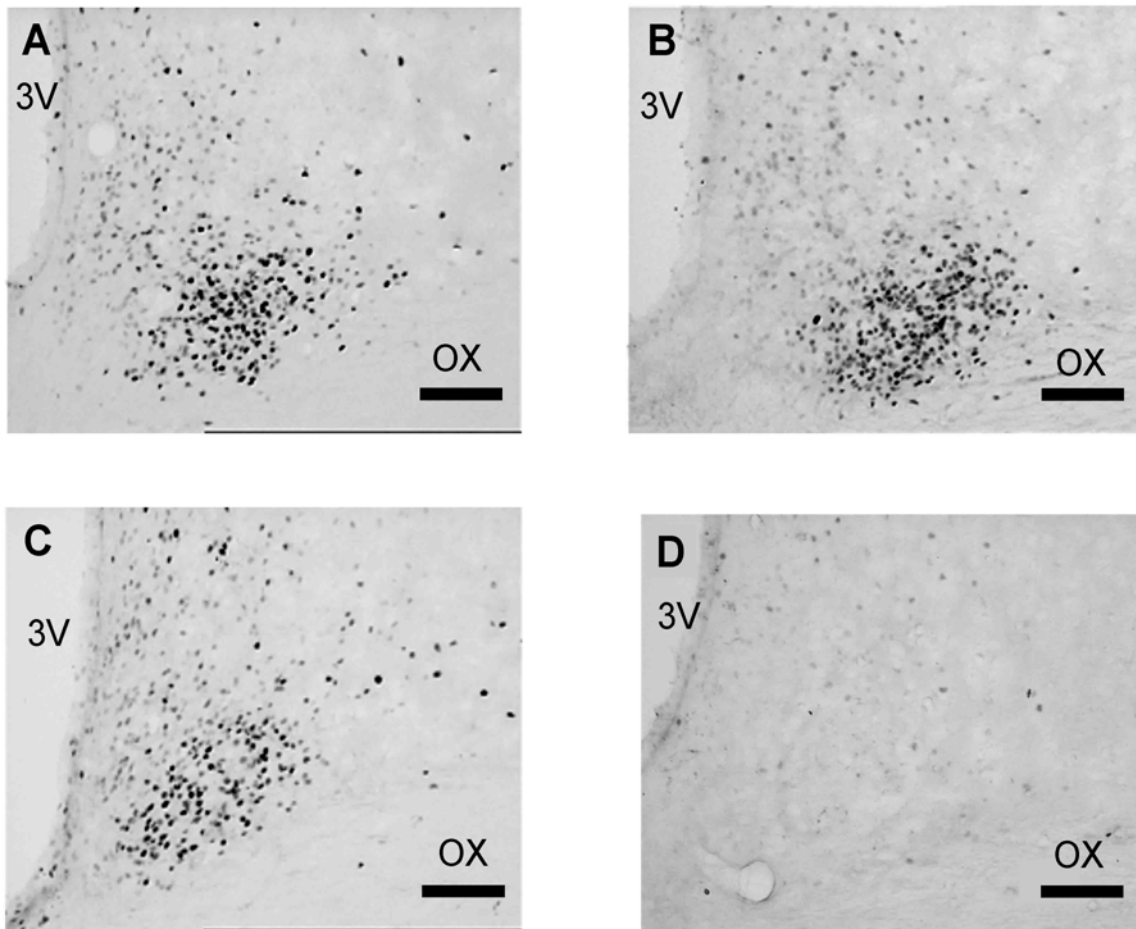

Figure 39. Representative photomicrographs showing *c-FOS* expression in the ventrolateral SCN of control (A), IGL-lesioned (B), 5-HT-lesioned (C) and enucleated rats (D) 2h after s.c. injections of quipazine at CT 22. OC = optic chiasm, 3V = third ventricle. Scale bar = 100 μ m.

Effect of quipazine on c-FOS expression

For the analysis of quipazine-induced c-FOS expression, sham-operated and intact animals of the three experimental groups were pooled in one control group. As shown in Figs. 39 and 40, administration of quipazine at CT 22 produced a pronounced expression of c-FOS in the ventrolateral SCN of control rats as well as in the SCN of IGL-lesioned and 5-HT-lesioned animals, but not in the SCN of enucleated rats. One-way ANOVA revealed a significant difference between groups ($F_{\text{surgery}}(3,40) = 9.54, p < 0.001$). Quipazine-induced c-FOS-ir was significantly lower in the SCN of enucleated rats ($378 \pm 105 \mu\text{m}^2$) compared to

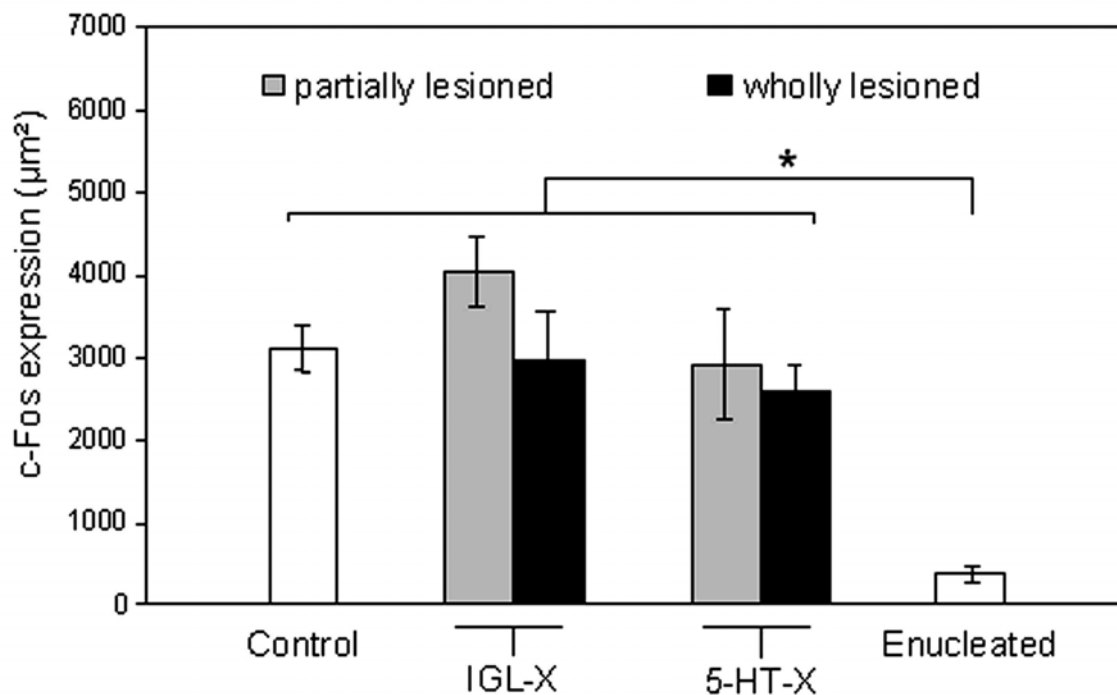

Figure 40. Comparison of quipazine-induced c-FOS expression (means \pm SEM) in the SCN of control ($n = 14$), IGL-lesioned (IGL-X, $n = 16$), 5-HT-lesioned (5-HT-X, $n = 9$) and enucleated rats ($n = 5$). IGL-lesioned animals are divided into partially ($n = 9$) and wholly ($n = 7$)-lesioned animals. 5-HT-lesioned animals are divided in partially ($n = 4$) and wholly ($n = 5$)-lesioned animals. $*p < 0.001$, post-hoc Tukey HSD test.

controls ($3090 \pm 307 \mu\text{m}^2$), IGL-lesioned rats (overall mean = $3579 \pm 358 \mu\text{m}^2$: “partially IGL-lesioned” rats = $4040 \pm 415 \mu\text{m}^2$, “wholly IGL-lesioned” rats = $2986 \pm 577 \mu\text{m}^2$) and 5-HT-lesioned rats (overall mean = $2736 \pm 327 \mu\text{m}^2$: “partially 5-HT-lesioned” rats = $2924 \pm 655 \mu\text{m}^2$, “wholly 5-HT-lesioned” rats = $2586 \pm 340 \mu\text{m}^2$).

Discussion

Lesions of IGL or 5-HT afferents to the SCN did not affect the photic-like effects of quipazine. However, bilateral enucleation and ensuing degeneration of the retinohypothalamic tract (RHT) abolished both the phase shifting and FOS-inducing effects of quipazine. These results suggest that photic-like effects of quipazine involve the RHT.

Photic-like effects of quipazine

The results of the present study are consistent with a number of *in vivo* studies demonstrating that serotonin has photic-like effects on the SCN in rats. For example, 5-HT agonists, such as quipazine, DOI or mCPP have been shown to induce photic-like phase shifts of locomotor activity (Kalkowski and Wollnik, 1999; Kohler *et al.*, 1999) and melatonin rhythms (Kennaway *et al.*, 1996, 2001; Kennaway, 1997; Kennaway and Moyer, 1998), c-FOS protein expression in the ventrolateral SCN (Moyer *et al.*, 1997; Kennaway and Moyer, 1998; Kalkowski and Wollnik, 1999; Kohler *et al.*, 1999; Ferguson and Kennaway, 2000) as well as *Per* gene expression in the SCN (Varcoe *et al.*, 2003). In addition, light-induced c-FOS protein expression in the rat SCN was reduced after application of the 5-HT_{1A} antagonist 1-(2-methoxyphenyl)-4(4-(2-phtalimido)butyl)piperazine (NAN-190) (Recio *et al.*, 1996) or after neurotoxic 5-HT depletion (Moyer and Kennaway, 2000). These findings suggest that the serotonergic regulation of these phenomena is mediated by a serotonergic control of the pathway conveying photic input to the SCN rather than acting directly on SCN neurons.

Findings obtained in rats are different from those obtained in hamsters and in mice, in which 5-HT has been described to inhibit photic input to the SCN (for reviews see Pickard and Rea, 1997; Morin, 1999). During subjective night, 5-HT agonists (8-OH-DPAT and N-(3-trifluoromethylphenyl)-piperazine HCl: TFMPP) partially or completely inhibit

light-induced phase shifts and c-FOS expression (Glass *et al.*, 1994; Rea *et al.*, 1994. Pickard *et al.*, 1996; Pickard and Rea, 1997) while 5-HT antagonists (NAN-190, WAY-100635 (N-[2-[4-(2-methoxyphenyl)-1-piperazinyl]ethyl]-N-2-pyridinyl-cyclohexanecarboxamine) and other mixed 5-HT_{1A} agonists/antagonists in hamster) potentiate the effects of light (Rea *et al.*, 1995; Smart and Biello, 2001; Gannon, 2003). Furthermore, there is substantial evidence for a role of 5-HT in the processing of non-photic stimuli in the circadian system of hamsters. For example, 5-HT agonists mimic the phase advancing effects of non-photic stimuli during subjective day (Tominaga *et al.*, 1992b; Cutrera *et al.*, 1996). In mouse, Antle *et al.* (2003) did not observe any phase shifting effects of 8-OH-DPAT applied during the subjective day, whereas Horikawa and Shibata (2004) found a clear phase advance after (+)8-OH-DPAT treatment. These divergent results clearly indicate species-dependent differences in 5-HT responsiveness of the circadian systems (Kohler *et al.*, 2000).

Species differences cannot explain the contradicting results between *in vivo* and *in vitro* studies in rats. For example, previous studies using isolated slice preparations of rat SCN revealed a non-photic rather than a photic effect of quipazine, with phase advances during subjective day and phase delays during subjective night (Prosser *et al.*, 1990, 1993). In addition, quipazine failed to induce *c-fos* mRNA during subjective night in the rat SCN *in vitro* (Prosser *et al.*, 1994b). One explanation for these differences may be that quipazine affects the circadian system of intact rats indirectly through other brain structures such as the raphe complex or the IGL. I.c.v. injections of quipazine close to the SCN during subjective night induce photic-like phase shifts of locomotor activity rhythm as well as c-FOS expression in the ventrolateral SCN (Kalkowski and Wollnik, 1999), implicating 5-HT receptors (pre and/or post-synaptic) located in this region. In addition, the present study demonstrated that the photic-like effects of quipazine are not mediated by the GHT or by 5-HT afferents from the raphe nuclei. Differences between *in vitro* and *in vivo* effects of quipazine in the rat may be due to the impairment of the retinal input in SCN brain slice preparations, after cutting the optic nerve. This hypothesis is clearly supported by the present study, because quipazine failed to phase shift the circadian system of enucleated animals.

A direct interaction between the RHT and the serotonergic system has already been demonstrated in other studies. Pre-treatment with the NMDA (N-methyl D-aspartate) antagonist MK-801 blocked phase shifting effect of the 5-HT agonist DOI and reduced by approximately 90% c-FOS induction in the SCN (Kennaway *et al.*, 1999). In addition, treatment of SCN slices with 5-HT not only increased the percentage of neurons responding

to glutamate but also potentiated the neuronal responses to glutamate (Huang and Pan, 1993). Furthermore, it has been shown that light induces c-FOS expression in SCN cells that are encircled by nerve terminals bearing serotonin transporter protein (Amir *et al.*, 1998). The hypothesis of Kennaway *et al.* (2001) was that 5-HT affects SCN interneurons directly via post-synaptic 5-HT_{2c} receptors. These interneurons should then release glutamate and activate SCN neurons further downstream. Instead, we propose that 5-HT affects the circadian system by modulating the pathway conveying photic input to the SCN, as suggested by Recio *et al.* (1996), and furthermore, that 5-HT stimulates or potentiates the effect of glutamate release from the terminals of the RHT via pre-synaptic receptor subtypes.

Presynaptic hypothesis

The results of the present study clearly demonstrate that an intact RHT is necessary for quipazine to mediate its photic-like effects. These findings suggest that quipazine and other 5-HT agonists may affect the circadian system of rats via presynaptic 5-HT receptors located within RHT terminals. Bilateral enucleation and the subsequent degeneration of the RHT would then result in the disappearance of these receptors and the photic-like effects of 5-HT agonists.

So far, presynaptic effects of 5-HT agonists have mostly been shown in hamsters and mice. 5-HT agonists block glutamate release during subjective night through the 5-HT_{1B} receptor subtype localized on the terminals of the RHT (Selim *et al.*, 1993; Srkalovic *et al.*, 1994; Pickard *et al.*, 1996; Pickard and Rea, 1997). Although a presynaptic 5-HT_{1B} receptor has also been demonstrated in the rat SCN (Manrique *et al.*, 1999), it is rather unlikely that quipazine may mediate its photic-like effect through such a receptor mechanism, because quipazine has a very low binding affinity for the 5-HT_{1B} receptor subtype (Zifa and Fillon, 1992). The 5-HT₃ receptor subtype is known to increase intracellular calcium concentration in glutamatergic terminals, thereby inducing the release of glutamate from RHT terminals (Nayak *et al.*, 1999; Van Hoof and Vijverberg, 2000). Therefore, we propose that quipazine exerts its effects upon the SCN via the 5-HT₃ receptor subtype for which quipazine has relatively high binding affinity (Zifa and Fillon, 1992). There is no experimental evidence for the 5-HT₃ receptor subtype in the SCN assayed by *in situ* hybridization (Roca *et al.*, 1993), however the lack of signal is to be expected, because the mRNA coding for such receptors should reside in their cell bodies and not in presynaptic terminals. Thus, 5-HT₃ mRNA should

be located in the retinal ganglion cells, but not in the SCN, while the protein should be present in the latter. However, previous autoradiography studies using [³H]quipazine failed to demonstrate any binding sites of 5-HT₃ receptor subtype in the SCN *in vivo* (Prosser *et al.*, 1993). It will be therefore necessary to proceed to 5-HT₃ immunohistology in the SCN, in order to prove the presence of the 5-HT₃ receptor subtype in the ventrolateral retinorecipient area of the SCN and its presynaptic localization. However, the only 5-HT₃ receptor antibody available, applied alone, seems not to be specific enough to build clear conclusions (Mazzia *et al.*, 2003).

Post-synaptic hypothesis

Kennaway and co-workers (2001) based their theory of a postsynaptic 5-HT_{2C} receptor pathway on experimental evidence showing that quipazine effects can be mimicked by application of specific 5-HT_{2C} agonists such as DOI, mCPP, and TFMPP, while drugs more specific for 5-HT_{1A/7} receptors (e.g. 8-OH-DPAT) are incapable of inducing phase shifts at CT 18 (Kennaway and Moyer, 1998). In addition, DOI and the highly selective 5-HT_{2C} agonist RO 60-0175 ((s)-2-(6-chloro-5fluoroindol-1-yl)-1-methylethylamine) increased both *c-fos* and *per* gene expression in the SCN (Varcoe *et al.*, 2003). Furthermore, DOI induced phase shifts and *c-FOS* expression were reduced by the relatively specific 5-HT_{2C} antagonist SB-242084 (6-chloro-5-methyl-1-[[2-(2-methylpyrid-3-yloxy)pyrid-5-yl]carbamoyl]indoline), as well as the atypical 5-HT_{2C} antagonists methylclozapine and clozapine (Kennaway *et al.*, 2001). Kennaway and co-workers (2001) have proposed that 5-HT_{2C} receptors located postsynaptically within the SCN play a role in the transmission of photic information in the rat circadian system. This is also consistent with anatomical studies demonstrating 5-HT_{2C} receptor mRNA and protein expression in the SCN of rats (Roca *et al.*, 1993; Moyer and Kennaway, 1999).

Nevertheless, a number of differences between Kennaway's and our own studies might explain the divergent results and interpretations. First, Kennaway and co-workers used nocturnal release of melatonin to quantify phase shifts while in our studies locomotor activity rhythms were analyzed. Second, the effects of quipazine and other 5-HT agonists were tested under different experimental protocols (Aschoff Type I versus Type II methods) and perhaps more importantly, at different circadian times. For example, quipazine-induced phase shifts of melatonin rhythm were largest at CT 18 (compared to CT 6 or CT 12), while CT 22 was not

tested (Kennaway *et al.*, 1996). In our hands, quipazine-induced phase delays and advances of locomotor activity were highest at CT 14 and CT 22, respectively (Kohler *et al.*, 1999; Kalkowski and Wollnik, 1999). Thus, it is possible that 5-HT uses different receptor subtypes to affect the various output parameters of the circadian clock.

Nevertheless, our results do not completely rule out the possibility that, in our experimental conditions, quipazine partly mediates its photic-like effects via postsynaptic 5-HT receptors. Indeed, it might be argued that RHT degeneration would induce a post-lesion down-regulation of postsynaptic 5-HT receptors and would thus either decrease receptor density or binding affinity. To our knowledge it has only been shown that specific neurotoxic lesions of the 5-HT terminals in the SCN result in an up-regulation of 5-HT_{1B} binding sites (Manrique *et al.*, 1994). Therefore, it remains to be determined whether other receptor subtypes show down-regulation after RHT degeneration.

Based on the current knowledge, 5-HT function in the circadian system seems to be varied and complex. One contributing factor is that multiple types of serotonin receptors are present in the SCN, and at different levels of the circadian system. Furthermore, if the expression pattern of these different receptor subtypes varies even slightly throughout the 24-h cycle, different drugs and different times of application could indeed induce different effects on the pacemaker. Therefore, *in vivo* experiments establishing phase response curves for the various 5-HT agonists combined with *in situ* hybridization as well as autoradiographic data should shed light on the exact nature and location of the 5-HT receptor subtype(s) mediating the photic-like effects of serotonergic activation.

Acknowledgments

This research was supported by the “Deutsche Forschungsgemeinschaft”. We wish to thank Dr. Etienne Challet for helpful comments on the manuscript, Dr. David Hicks for English revision and Angeline Votteler for excellent technical assistance.

Appendum

Results presented in the previous article showed that the RHT degeneration following enucleation, is able to block the photic-like resetting effects of quipazine while lesions of either the GHT or the serotonergic tract are not. These results indicate that the 5-HT receptor(s) involved are located on terminals of the RHT.

This raised the question concerning the subtype of the 5-HT receptor(s) implicated in the photic-like shifting effects of 5-HT agonists. As exposed in the previous article, it is rather unlikely that postsynaptic 5-HT receptors, like the 5-HT_{2C} receptor subtype, mediate these effects of quipazine. Moreover, inhibitory presynaptic 5-HT receptors, like 5-HT_{1B} receptors, could not explain the photic-like effects of quipazine on the clock. Based on the literature, the 5-HT₃ receptor subtype seems to be a good candidate. Indeed, activation of this receptor increases the intracellular calcium concentration in terminals (Nayak *et al.*, 1999), induces the release of glutamate (Ashworth-Preece *et al.*, 1995; Wang *et al.*, 1998; Sevoz-Couche *et al.*, 2002; Funahashi *et al.*, 2004) acting on postsynaptic NMDA receptors (Wang *et al.*, 1998; Reges *et al.*, 2002). Despite the fact that the localization of this receptor in the SCN is not clear, activation of this 5-HT receptor subtype could induce photic-like effects of 5-HT agonists in rats, through its action on glutamate release from the RHT and subsequent activation of NMDA receptors.

We thus decided to test the implication of the 5-HT₃ receptor in the photic-like effects of quipazine, by using of a specific 5-HT₃ agonist and a specific 5-HT₃ antagonist, as well as the implication of the NMDA receptors, by using of a specific NMDA receptor antagonist. Three circadian parameters have been analyzed, i.e. the locomotor activity rhythm as well as c-FOS and various clock genes expression in the SCN.

Article 3

5-HT₃ receptor-mediated photic-like responses of the circadian clock in the rat

Caroline Graff, Etienne Challet, Paul Pévet and Franziska Wollnik

Submitted

Abstract

Serotonin (5-HT) and 5-HT agonists have various resetting effects on the master clock, located in the suprachiasmatic nucleus (SCN), depending on the species. In rats, they induce photic-like effects on locomotor activity rhythm as well as on gene expression in the SCN. The 5-HT receptor(s) mediating these effects at circadian time 22 are localized in the suprachiasmatic nucleus and most likely at a presynaptic level, on the retinohypothalamic terminals (RHT) known to convey photic information by releasing glutamate. Indeed, RHT degeneration blocks photic-like effects of a non-specific 5-HT agonist, quipazine. However, the 5-HT receptor subtype(s) involved is still unknown, although 5-HT₃ receptor activation is known to induce glutamate release. We thus analyzed the effects of specific 5-HT₃ agonist and antagonist as well as a specific NMDA receptor antagonist on different parameters of the clock. This study shows that the 5-HT₃ receptor mediates the resetting effects of quipazine on locomotor activity rhythm. Moreover, the 5-HT₃ receptor is only partially implicated in quipazine-induced expression of c-FOS. In addition, NMDA receptor inhibition blocks quipazine photic-like effects on both parameters. Taken together, photic-like responses produced by 5-HT stimulation in rats are likely mediated by presynaptic 5-HT₃ receptor activation followed by NMDA receptor activation.

Introduction

In mammals, the master clock located in the suprachiasmatic nuclei (SCN) of the hypothalamus is able to generate and distribute a rhythmic message to the whole body (Morin, 1994). The SCN can be entrained by photic cues, i.e. light (Pittendrigh and Daan, 1976) and non photic cues, such as access to a running wheel (Mrosovsky *et al.*, 1989) or triazolam injection (Van Reeth and Turek, 1989).

External information reaches the SCN through 3 major inputs. The first one is the retinohypothalamic tract (RHT) which comes from the retina and releases glutamate (Morin, 1994) and pituitary adenylate cyclase-activating polypeptide (PACAP) (Hannibal *et al.*, 1997). The second SCN input is the geniculohypothalamic tract (GHT) which originates in the retinorecipient area of the intergeniculate leaflet (IGL) and releases neuropeptide Y (NPY) and γ -aminobutyric acid (GABA) (Morin, 1994). The third SCN input is a dense serotonergic

projection coming directly from the median raphe nucleus (MRN) and indirectly from the dorsal raphe nucleus (DRN) via the IGL (Azmitia and Segal, 1978; Hay-Schmidt *et al.*, 2003). Furthermore, a tract connecting the retina with the DRN has been demonstrated in rats (Kawano *et al.*, 1996). However, this pathway has not been detected in golden hamsters (Morin, 1994).

Serotonin (5-HT) agonists have different resetting properties depending on the species (Kohler *et al.*, 2000). In hamsters, systemic (Tominaga *et al.*, 1992b; Cutrera *et al.*, 1996; Schuhler *et al.*, 1998) or local injection of 5-HT agonists such as 8-OH-DPAT (8-hydroxy-di-*n*-propylamino tetralin) in the SCN (Challet *et al.*, 1998c) during the subjective day induce phase advances of the locomotor activity that mimic the effect of non photic stimuli. Moreover, 8-OH-DPAT decreases *Per1* and *Per2* mRNA levels in the SCN (Horikawa *et al.*, 2000) as do non photic stimuli, like novel-wheel running (Maywood *et al.*, 1999). Besides direct effects on the SCN clock during the subjective day, serotonergic stimulation modulates photic input to the SCN during the subjective night. Systemic (Rea *et al.*, 1994) as well as local injections of 8-OH-DPAT (Weber *et al.*, 1998) decrease the magnitude of light-induced phase shifts of locomotor activity rhythm, block the light-induced firing increase of SCN neurons (Ying and Rusak, 1994), induce the release of glutamate in the SCN (Srkalovic *et al.*, 1994), as well as the stimulation of c-FOS protein immunoreactivity in SCN cells (Rea *et al.*, 1994). Similar results were obtained with 5-HT (Selim *et al.*, 1993; Ying and Rusak, 1994) and other 5-HT agonists like quipazine (Selim *et al.*, 1993) or 5-CT (5-carboxamidotryptamine) (Ying and Rusak, 1997). Results obtained in mice were almost the same as those gathered in hamsters (Pickard *et al.*, 1999; Horikawa and Shibata, 2004), albeit with small differences (Antle *et al.*, 2003).

Contrary to the results obtained in hamsters and mice, a serotonin stimulation in the rat seems to enhance, rather than reduce, photic responses. Systemic injections of 5-HT agonists such as quipazine or the more specific 5-HT_{2C} agonists, DOI ((±)-1-(2,5-dimethoxy-4-iodophenyl)-2-aminopropane HCL) and mCPP (1-(3-chlorophenyl)-piperazine HCL) induce photic-like phase shifting of the circadian rhythms of locomotor activity and melatonin (Kennaway and Moyer, 1998, 1999; Kohler *et al.*, 1999). Furthermore, quipazine (Moyer *et al.*, 1997) and DOI, systemically injected induce c-FOS expression in the ventrolateral area of the SCN during the subjective night, but not during the subjective day (Moyer *et al.*, 1997; Kennaway and Moyer, 1998, 1999; Kohler *et al.*, 1999). Similar effects of quipazine were demonstrated after its local injection into the SCN (Kalkowski and Wollnik, 1999). Moreover,

systemic injections of DOI can induce the expression of *Per1* and *Per2* during the subjective night (Varcoe *et al.*, 2003).

Concerning *in vitro* studies on rat SCN slices, only non photic effects of 5-HT agonists on the SCN neurons firing rate rhythm have been demonstrated (Prosser *et al.*, 1993). These differences between the *in vitro* and *in vivo* effects of quipazine in rats could suggest that systemically administered quipazine may affect the circadian system not only directly at the level of the SCN, but also through other brain structures such as the raphe or the IGL. However, i.c.v. injections of quipazine close to the SCN during the subjective night induce photic-like phase shifts of locomotor activity rhythm as well as c-FOS expression in the ventrolateral SCN (Kalkowski and Wollnik, 1999), implicating 5-HT receptors (pre and/or post-synaptic) located in this region.

Our recent study provides strong arguments for an involvement of 5-HT receptors located on the RHT terminals (Graff *et al.*, 2005). Indeed, degeneration of the RHT, resulting from bilateral enucleation, blocks the photic-like effects of quipazine on locomotor activity rhythm as well as on c-FOS expression in the SCN. At the opposite, degeneration of the GHT following bilateral IGL lesion and lesion of 5-HT input to the SCN with a specific neurotoxin, the 5,7-dihydroxytryptamine (5,7-DHT), do not abolish those photic-like effects of quipazine. These results raise the question of knowing which 5-HT receptor(s), located on the RHT, could be responsible for the photic-like effects of 5-HT agonists. The 5-HT₃ receptor subtype is a good candidate, since it has been shown to increase intracellular calcium concentration in glutamatergic terminals, thereby inducing the release of glutamate (Van Hooft and Vijverberg, 2000; Funahashi *et al.*, 2004) and subsequent NMDA receptor activation (Reges *et al.*, 2002). The aim of this study was thus to test the implication of the 5-HT₃ receptor activation and the subsequent glutamate release in the photic-like serotonergic effects. We used specific 5-HT₃ agonist and antagonist as well as a specific NMDA receptor antagonist. The parameters analyzed were locomotor activity rhythm, c-FOS expression and clock gene expression in the SCN.

Methods

Animals

Male inbred LEW/Ztm (albino) rats were housed individually in plastic cages (35 x 55 x 15 cm) equipped with a running wheel (diameter 35 cm, width 10 cm) under standard laboratory conditions (light/dark: LD 12:12, lights on at 07:00 h, 20±1°C, 50±5% relative humidity) with food and water ad libitum for at least 2 weeks before the start of the experiments. Running wheel revolutions were recorded by a computer and collected in 5 min bins. All experiments with animals were performed in accordance with European Communities Council Directive of November 24, 1986 (86/609/EEC) as well as in accordance with the German law. All efforts were made to minimize the number of animals used and any potential suffering.

Experimental protocol

First set of experiments: Effect of serotonergic and glutamatergic drugs on the locomotor activity rhythm

The animals were transferred to constant darkness (DD) for at least ten days before receiving the injections.

In experiment 1, rats received either vehicle (saline; s.c.) (n = 6) or different doses of quipazine (a non specific 5-HT receptor agonist) (Sigma-Aldrich Chemie GmbH, Deisenhofen, Germany; subcutaneous: s.c.): 0.3 mg/kg (n = 6), 1 mg/kg (n = 6), 3 mg/kg (n = 6) and 10 mg/kg (n = 4) in order to determine the most suitable dose.

In experiment 2, the rats received injections of either: (1) vehicle (saline; s.c.) (n = 6), (2) m-chlorophenylbiguanide (m-CPBG, a specific 5-HT₃ receptor agonist) (Tocris Cookson, Bristol, United Kingdom; 5 mg/kg intraperitoneal: i.p.) (n = 4), (3) quipazine (3 mg/kg, s.c.) (n = 6), (4) ondansetron hydrochloride dihydrate (a specific 5-HT₃ receptor antagonist) (Glaxo Smith Kline Laboratories, UK; 3 mg/kg, i.p.) 10 min before saline (n = 6) or (5) ondansetron 10 min before quipazine (n = 6) at the same doses as for (4) and (3) respectively.

In experiment 3, the rats received injections of either: (1) vehicle (saline, s.c.) (n = 4), (2) quipazine (3 mg/kg) (n = 4), (3) (+)-5-methyl-10,11-dihydroxy-5h-dibenzo (a,d)cyclohepten-5,10-imine (MK-801, a specific NMDA receptor antagonist) (Sigma-Aldrich Chemie GmbH, Deisenhofen, Germany; 3 mg/kg i.p.) 10 min before saline (n = 4) or (4) MK-801 10 min before quipazine (n = 4) at the same doses as for (3) and (2) respectively.

All injections were performed at circadian time (CT) 22. We chose CT 22 because phase shifts as well as c-FOS expression were highest at this circadian phase compared to other CTs (Kohler *et al.*, 1999). All injections were performed using a darkroom red light source (< 0.5 lux, Kindermann, Berlin, Germany). Both groups of animals remained in DD, in their cages at least for 10 days after the injection.

Second set of experiments: Effect of serotonergic and glutamatergic drugs on the expression of c-FOS in the SCN

The animals were transferred to DD for at least ten days before receiving the injections or treatment.

In experiment 4, the rats received a 2 h light pulse (LP) (about 250 lux) (n = 5) or injections of either: (1) vehicle (saline, s.c.) (n = 4), (2) m-CPBG (5 mg/kg, i.p.) (n = 4), (3) quipazine (3 mg/kg, s.c.) (n = 10), (4) ondansetron (3 mg/kg, i.p.) 10 min before saline (n = 10) or (5) ondansetron 10 min before quipazine (n = 10) at the same doses as in experience 2.

In experiment 5, the rats received injections of either: (1) vehicle (saline, s.c.) (n = 4), (2) quipazine (3 mg/kg, s.c.) (n = 4), (3) MK-801 (3 mg/kg, i.p.) 10 min before saline (n = 4) or (4) MK-801 10 min before quipazine (n = 3) at the same doses as in experiment 3.

In experiment 6, the rats received injections of either: (1) vehicle (saline, s.c.) (n = 5), (2) quipazine (3 mg/kg, s.c.) (n = 5), (3) 6-Chloro-5-methyl-1-[[2-(2-methylpyrid-3-yloxy)pyrid-5-yl] carbamoyl] indoline dihydrochloride (SB-242084, a specific 5-HT_{2C} receptor antagonist) (Sigma-Aldrich Chimie S.a.r.l., Lyon, France; 1 mg/kg i.p., diluted in dimethylsulphoxide 50%) 10 min before saline (n = 5) or (4) SB-242084 10 min before quipazine (n = 5) at the same doses as for (3) and (2) respectively.

All injections were followed 2 h later, by a deep anesthesia and a transcardial perfusion with 200 ml phosphate-buffered saline (0.1 M PBS, pH 7.4) containing 0.1% heparin (Roth, Karlsruhe, Germany) followed by 200 ml 4% paraformaldehyde in 0.1M PBS, pH 7.4. The

brains were removed, post-fixed in the same fixative for 24 h and then cryoprotected in 30% sucrose in PBS for 3 days. The brains were then cut and proceeded for c-FOS immunocytochemistry.

Experiment 7: Effect of serotonergic drugs on the expression of clock genes in the SCN

The animals were transferred to DD for at least ten days before receiving the injections. The animals received injections of either: (1) vehicle (saline, s.c.) (n = 4), (2) m-CPBG (5 mg/kg, i.p.) (n = 5), (3) quipazine (3 mg/kg) (n = 6) or (4) quipazine (10 mg/kg) (n = 5). The animals were deeply anesthetized 1h after the injection and sacrificed by decapitation. Brains were rapidly removed, frozen in isopentane maintained at -30°C and stored at -80°C .

Behavior analyses

Onsets of nocturnal locomotor activity were determined during the 10 days before and after the injection. For assessment of the phase shifts induced by the injections, linear regression analysis of the onset of activity (Clocklab software; Actimetrics, Evanston, IL) was performed. The phase shifts were defined as the average difference between the two lines on the day after the injection.

Histological procedures

c-FOS immunocytochemistry procedure

The brains were cut through the SCN on a freezing microtome and the 30 μm sections collected in 0.1 M PBS containing 0.1% Triton X-100 (PBST). The sections (25 for each brain) were then processed for c-FOS immunohistochemistry. Briefly, free-floating sections were rinsed in PBST and then incubated in c-FOS primary antibody (Calbiochem, Schwalbach, Germany, 1:10000) for 18 h at room temperature. Sections were then processed using the Vectastatin ABC kit (Vector Laboratories, Burlingame, CA, USA) with diaminobenzidine as the chromogen. The expression of c-FOS immunoreactivity (ir) was determined using a computerized software system. The mean area of c-FOS-ir was assessed

within a pre-defined area of interest covering the whole SCN and divided in a dorsomedial (DM) and ventrolateral (VL) region (Fig. 41).

In situ hybridization of clock genes

Here we used riboprobes of *rPer1* (981 bp), *rPer2* (760 bp), *mCry1* (516 bp), *mCry2* (468 bp), *rBmal1* (1735 bp) and *rRev-erb α* (983 bp). *rPer1* and *rPer2* plasmid were kindly provided by Dr. H. Okamura (University of Kobe, Japan). Clones of *mCry1*, *mCry2*, *rBmal1* and *rRev-erb α* were generated by RT-PCR from rat RNA extracts. PCR products of the expected size were cloned into the PCR-Script SK(+) cloning vector (Stratagene, Amsterdam,

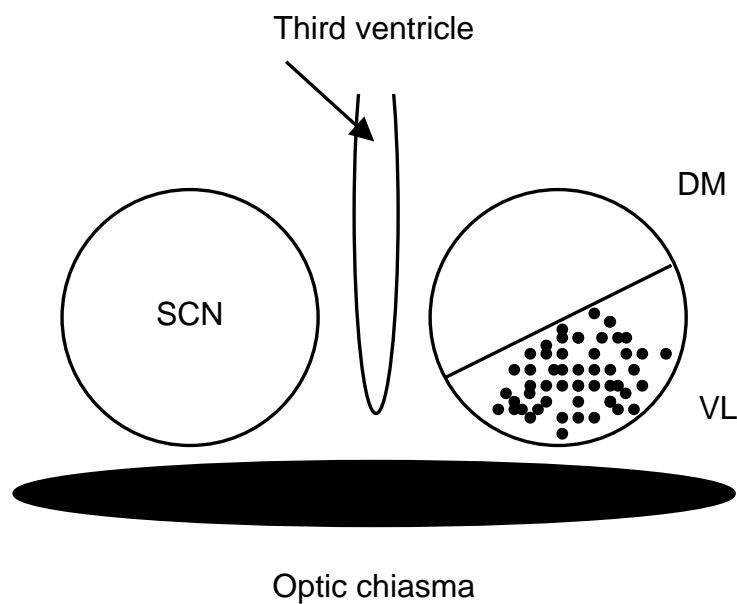

Figure 41. Picture of the pre-defined area of interest for *c-FOS* immunoreactive cells quantification. Example of *c-FOS* induction after quipazine injection. *c-FOS*-immunoreactive cells may be quantified in the whole nucleus as well as in its ventrolateral (VL) and dorsomedial (DM) part. SCN = suprachiasmatic nucleus.

The Netherlands). Identity and orientation of the cloned PCR fragments were confirmed by sequencing (AGOWA Sequencing Services, Berlin, Germany). *mCry1* cDNA covers nucleotides 1394-1909 of GenBank accession number AF156986, *mCry2* cDNA covers nucleotides 955-1422 of GenBank accession number AF156987, *rBmall* cDNA covers nucleotides 75-1809 of GenBank accession number AB012600 and *rRev-erb α* cDNA covers nucleotides 908-1890 of GenBank accession number NM_145775. Serial coronal sections (20 μ m thick) of the region containing the SCN were cut on a freezing microtome, thaw mounted onto gelatin coated slides and kept at -20°C until use. Antisense and sense RNA probes were transcribed in the presence of α [^{35}S]-UTP (1200 Ci/mmol, Amersham, Saclay, France) according to the manufacturer's protocol (MAXIscript, Ambion, USA). *In situ* hybridization was performed as previously described (Gauer *et al.*, 1998). Slides were then exposed for one week with radioactive standards in each cassette to verify that measured values were in the linear response range of the autoradiographic film (Biomax MS-1 Kodak; Sigma, St. Louis, MO). Quantitative analysis of the autoradiograms was performed using the computerized analysis system Biocom-program RAG 200.

For each probe and each animal, quantification was performed on both SCN on four subsequent sections. Specific signal intensity was obtained by subtraction of the background intensity measured in the anterior hypothalamic area. Data are depicted as arbitrary units (a.u.).

Statistics

Statistical comparisons between treatments were performed by one-way analyses of variance (ANOVA). In the case of significant main effects, the LSD Fisher test was used for post hoc comparison of means.

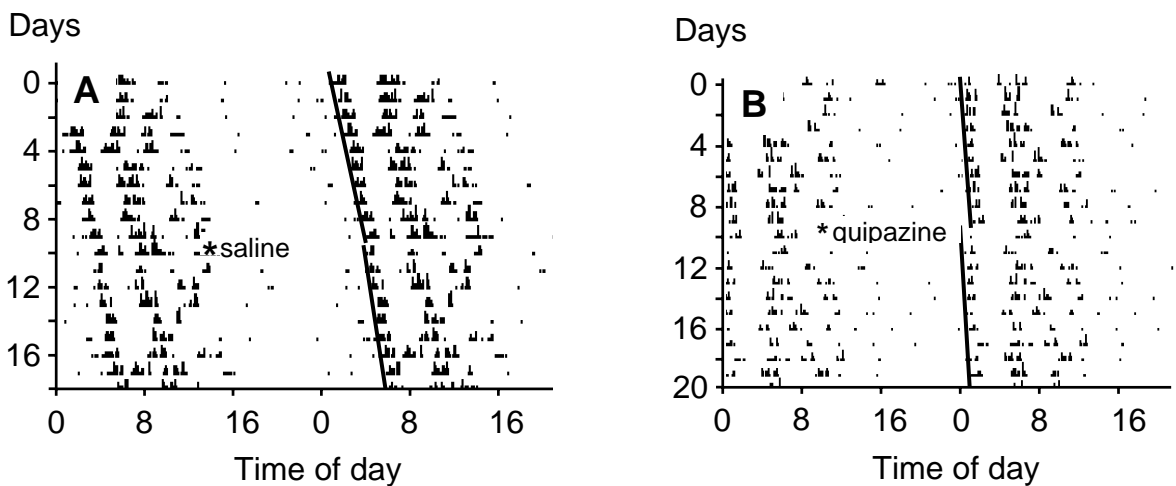

Figure 42. Double-plotted wheel-running activity records of rats before and after s.c. injections of saline (A) or quipazine (3 mg/kg) (B) at CT 22. Lines on the vertical axes denote 2 day intervals, whereas numbers on the horizontal axes denote time of day. To visualize phase shifts of the activity rhythm, eye-fitted lines are drawn through the onset of the activity rhythm before and after treatment. Saline or quipazine injection times are indicated by asterisks.

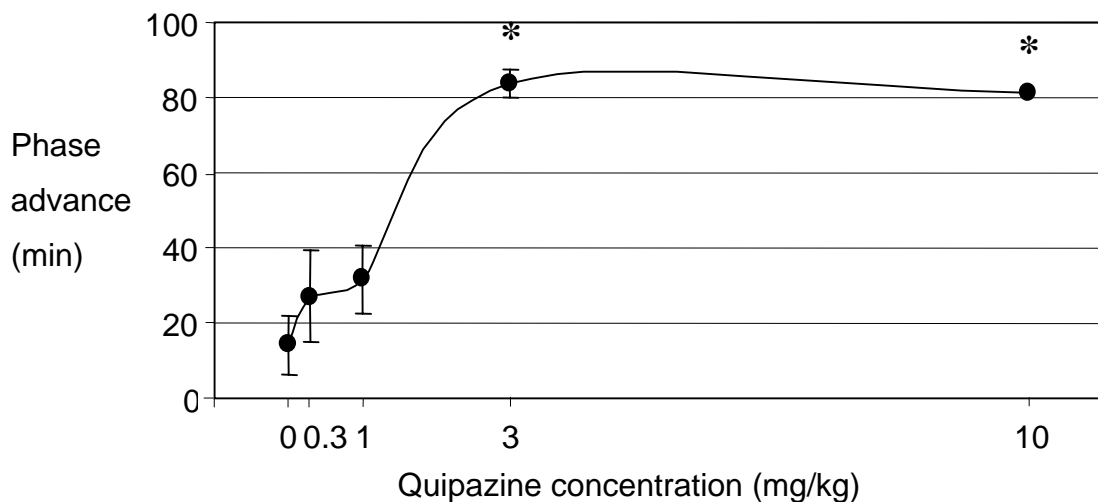

Figure 43. Quipazine dose-response curve on locomotor activity rhythm. Phase advances of the locomotor activity rhythm were analyzed after s.c. quipazine injection at 0.3 (n = 6), 1 (n = 6), 3 (n = 6) and 10 mg/kg (n = 4). * $p < 0.005$, post-hoc LSD Fisher test.

Results

First set of experiments: Effect of serotonergic and glutamatergic drugs on the locomotor activity rhythm

In experiment 1, different doses of quipazine were tested at CT 22: 0.3, 1, 3 and 10 mg/kg as well as vehicle (Fig. 42, 43). One-way ANOVA revealed a significant effect of quipazine concentration ($F_{concentration} (3,18) = 10.81, p < 0.001$). Phase advances of locomotor activity rhythm were significantly higher in animals that received 3 or 10 mg/kg (84 ± 9 min and 81 ± 4 min, respectively) compared to animals that received 0.3 or 1 mg/kg of quipazine (27 ± 8 min and 32 ± 12 min, respectively) or saline (14 ± 9 min) ($p < 0.005$). Thus, the minimal quipazine concentration for inducing maximal phase advances of the locomotor activity was 3 mg/kg, which was used in all subsequent experiments.

Rats of experiment 2, received injections of either saline, m-CPBG (a specific 5-HT₃ receptor agonist), quipazine (3 mg/kg) and ondansetron (a specific 5-HT₃ receptor antagonist) before saline or quipazine (3 mg/kg) (Fig. 44). One-way ANOVA revealed a significant effect of injections ($F_{injections}(4,23) = 17.36, p < 0.001$). m-CPBG as well as quipazine induced phase advances (84 ± 9 min and 66 ± 5 min, respectively) significantly different ($p < 0.001$) compared to saline (14 ± 9 min). In addition, phase advances did not differ significantly between animals that received ondansetron injected before quipazine (6 ± 4.5 min) and those that received injections of either ondansetron before saline (17 ± 11 min) or saline alone (14 ± 9 min). Thus, quipazine as well as m-CPBG induced phase advances of the locomotor activity rhythm, while ondansetron was able to block the effect of quipazine on the locomotor activity rhythm at CT 22.

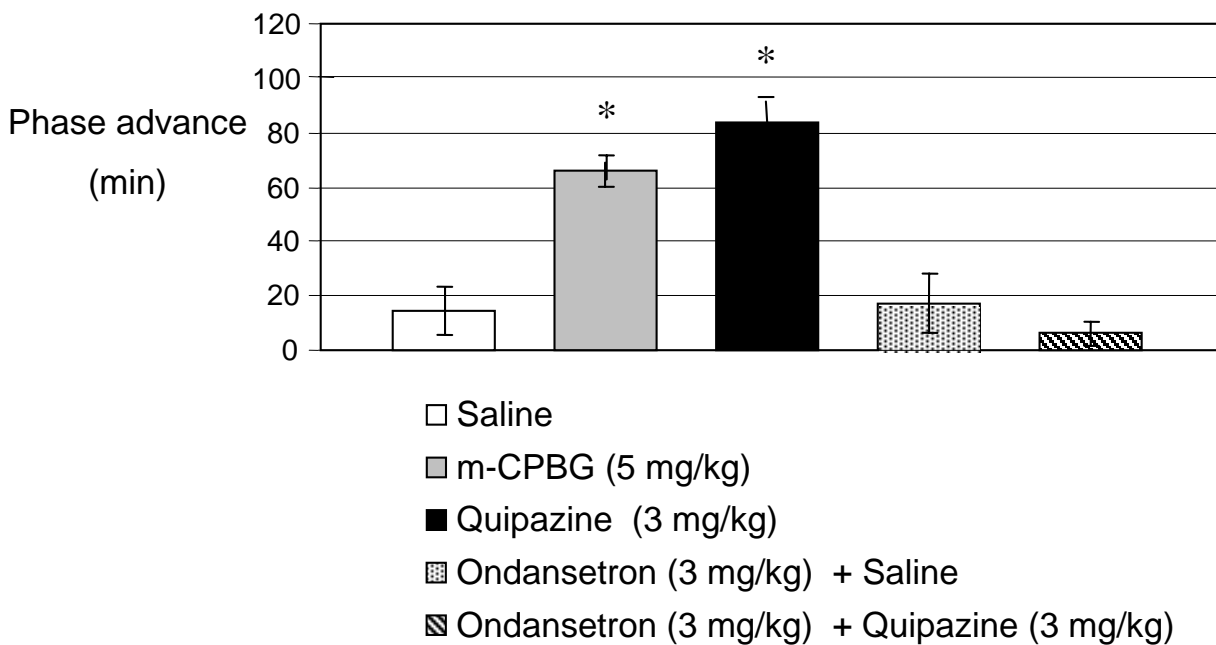

Figure 44. Comparison of phase advances (means \pm SEM: standard error of mean) observed after different injections at CT 22: saline (s.c.) ($n = 6$), m-CPBG (5 mg/kg, i.p.) ($n = 4$), quipazine (3 mg/kg, s.c.) ($n = 6$), pretreatment with ondansetron (3 mg/kg, i.p.) followed by saline ($n = 6$) and pretreatment with ondansetron followed by quipazine ($n = 6$). * $p < 0.001$, post-hoc LSD Fisher test.

In experiment 3, the rats received injections of either saline, quipazine (3 mg/kg) and MK-801 (a specific NMDA receptor antagonist) before saline or quipazine (3 mg/kg) (Fig. 45). One-way ANOVA revealed a significant effect of injections ($F_{\text{injections}}(3,12) = 7.80$, $p < 0.005$). Quipazine-induced phase advances (64 ± 3 min) that were significantly different ($p < 0.001$) from those observed after saline (13 ± 14 min), MK-801 before saline (28 ± 7 min), or MK-801 before quipazine (19 ± 6 min). Thus, MK-801 was able to block the effect of quipazine on the locomotor activity rhythm at CT 22.

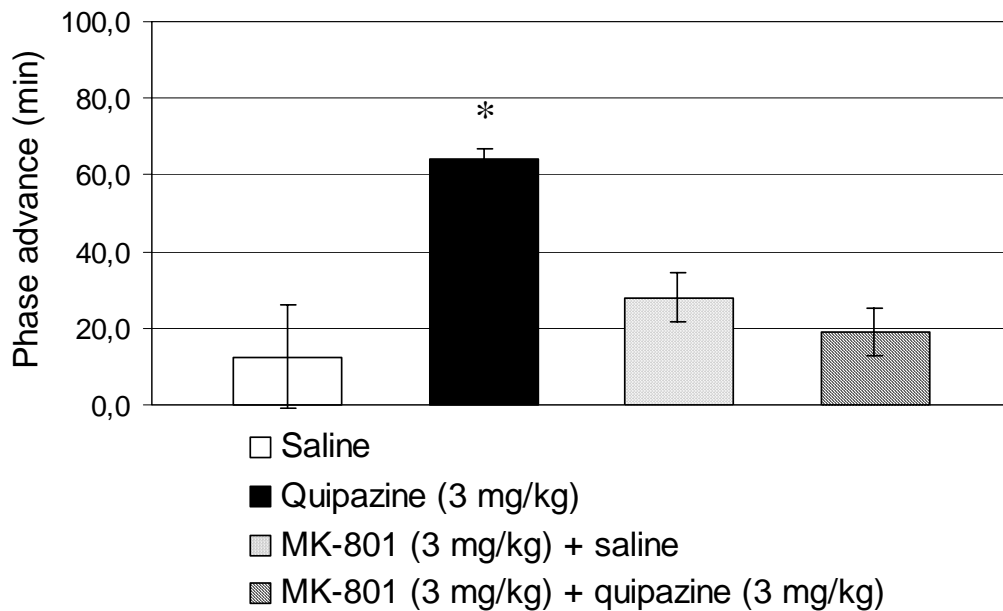

Figure 45. Comparison of phase advances (means \pm SEM) observed after different injections at CT 22: saline (s.c.) ($n = 4$), quipazine (3 mg/kg, s.c.) ($n = 4$), pretreatment with MK-801 (3 mg/kg, i.p.) followed by saline ($n = 4$) and pretreatment with ondansetron followed by quipazine ($n = 4$). * $p < 0.001$, post-hoc LSD Fisher test.

Second set of experiments: Effect of serotonergic and glutamatergic drugs on the expression of c-Fos in the SCN

Fig. 46 shows representative picture of c-FOS immunohistochemistry in the SCN induced by saline (3 mg/kg) and quipazine injections. Quipazine at 3 mg/kg induced the expression of c-FOS in the SCN, mainly in the ventrolateral region, compared to saline injection.

The rats of experiment 4 received a 2 h light pulse (LP) or injections of either saline, m-CPBG, quipazine (3 mg/kg), ondansetron before saline or ondansetron before quipazine (3 mg/kg). c-FOS immoreactivity (ir) was first assessed in the whole SCN. Fig. 47 shows mean c-FOS-ir induced by these different injections. One-way ANOVA revealed a significant effect of treatments ($F_{treatments} (5,37) = 10.68, p < 0.001$) on c-FOS expression in the whole SCN. LP, quipazine (3 mg/kg) as well as m-CPBG induced a c-FOS expression (LP: $4453 \pm 486 \mu\text{m}^2, p < 0.001$; quipazine: $2616 \pm 185 \mu\text{m}^2, p < 0.01$ and m-CPBG: $4176 \pm 600 \mu\text{m}^2, p < 0.001$) that was significantly different from that induced by saline ($1142 \pm 343 \mu\text{m}^2$). Moreover, c-FOS expression in the whole SCN induced by ondansetron before saline ($1935 \pm$

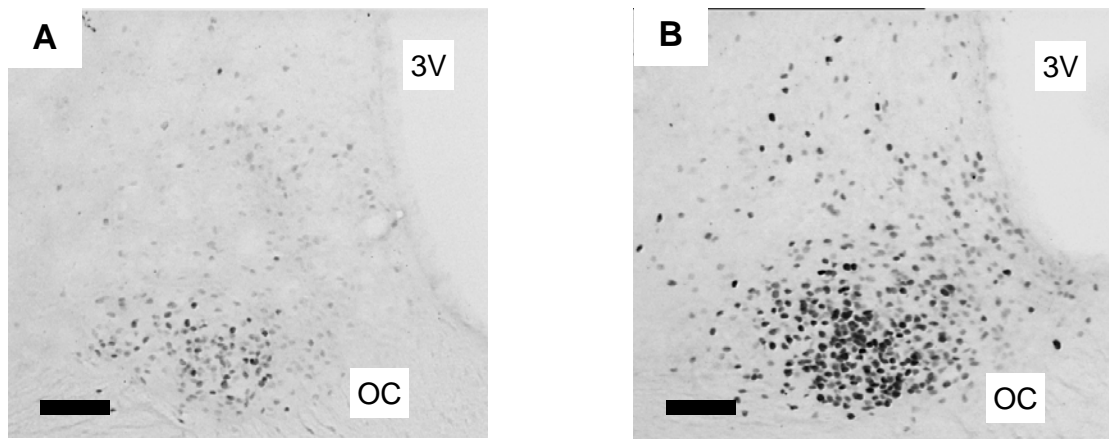

Figure 46. Representative photomicrographs showing c-FOS expression in the ventrolateral SCN of rats after s.c. injections at CT 22 of saline (A) or quipazine (3 mg/kg) (B). OC = optic chiasm, 3V = third ventricle. Scale bar = 100 μm .

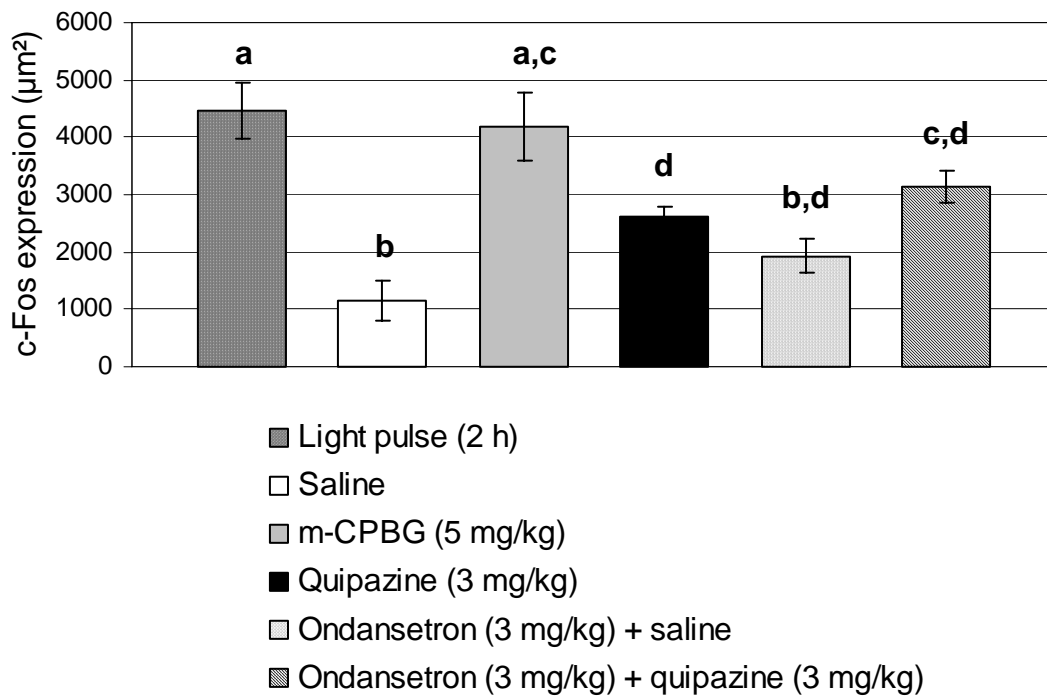

Figure 47. Comparison of c-FOS expression (means \pm SEM) in the whole SCN of rats, induced at CT 22 by a 2 h LP (about 250 lux) ($n = 5$) or by injections of either saline (s.c.) ($n = 4$), m-CPBG (5 mg/kg, i.p.) ($n = 4$), quipazine (3 mg/kg, s.c.) ($n = 10$), pretreatment with ondansetron (3 mg/kg, i.p.) followed by saline ($n = 10$) or pretreatment with ondansetron followed by quipazine ($n = 10$). Absence of shared letters above each column denotes significant difference, $p < 0.05$, post-hoc LSD Fisher test.

284 μm^2) was not significantly different from that induced by saline. However, c-FOS expression in the whole SCN was significantly different in animals that received ondansetron before quipazine ($3137 \pm 293 \mu\text{m}^2$) compared to animals that received injections of ondansetron before saline ($p < 0.05$). In addition, no significant differences was found between c-FOS expression in animals that received ondansetron before quipazine and c-FOS expression in animals that received quipazine alone. A similar pattern of changes was found in both VL and DM regions of the SCN (data not shown).

In experiment 5, the rats received injections of either saline, quipazine (3 mg/kg), MK-801 before saline or MK-801 before quipazine (3 mg/kg). c-FOS-ir was first assessed in the whole SCN. Fig. 48 shows mean c-FOS-ir induced by these different injections. One-way ANOVA revealed a significant effect of treatments ($F_{\text{treatments}}(3,11) = 7.64$, $p < 0.005$) on c-FOS expression in the whole SCN. Quipazine induced a c-FOS expression ($3729 \pm 648 \mu\text{m}^2$) that was significantly different ($p < 0.005$) compared to saline ($1293 \pm 345 \mu\text{m}^2$). Moreover, c-FOS expression in the SCN induced by MK-801 before saline ($1558 \pm 281 \mu\text{m}^2$) did not differ significantly from those induced by either saline or MK-801 before quipazine ($1458 \pm 101 \mu\text{m}^2$). Similar results were obtained in both VL and DM regions of the SCN (data not shown).

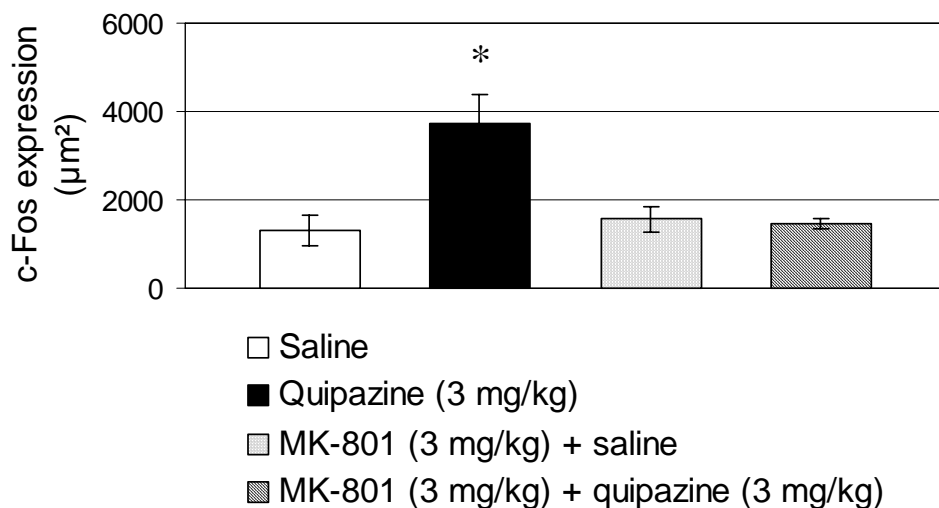

Figure 48. Comparison of c-FOS expression (means \pm SEM) in the whole SCN of rats induced at CT 22 by injections of either saline (s.c.) ($n = 4$), quipazine (3 mg/kg, s.c.) ($n = 4$), pretreatment with MK-801 (3 mg/kg, i.p.) followed by saline ($n = 4$) or pretreatment with MK-801 followed by quipazine ($n = 3$). * $p < 0.005$, post-hoc LSD Fisher test.

In experiment 6, the rats received injections of either saline, quipazine (3 mg/kg), SB-242084 (a specific 5-HT_{2C} receptor antagonist) before saline or SB-242084 before quipazine (3 mg/kg). c-FOS-ir was first assessed in the whole SCN (Fig. 49). One-way ANOVA revealed a significant effect of injections ($F_{injections} (3,15) = 9.54, p < 0.001$) on c-FOS expression in the whole SCN. c-FOS expression in the whole SCN was significantly higher in animals that had received either quipazine alone ($3157 \pm 251 \mu\text{m}^2$) or SB-242084 before saline ($1862 \pm 170 \mu\text{m}^2$) or saline alone ($1732 \pm 189 \mu\text{m}^2$). A similar pattern of changes was found in the VL, but not the DM region of the SCN (data not shown).

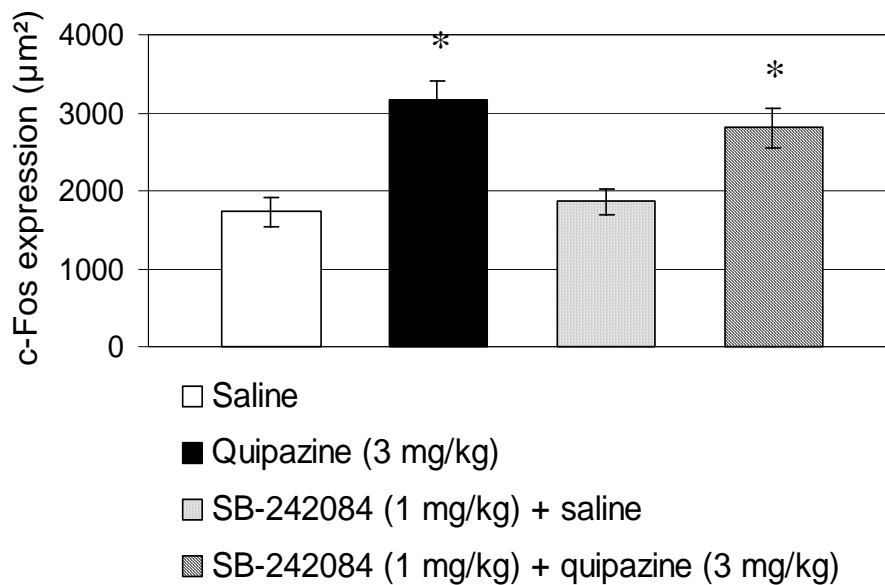

Figure 49. Comparison of c-FOS expression (means \pm SEM) in the whole SCN of rats induced at CT 22 by injections of either saline (s.c.) ($n = 5$), quipazine (3 mg/kg, s.c.) ($n = 5$), pre-treatment with SB-242084 (1 mg/kg, i.p.) followed by saline ($n = 5$) or pre-treatment with SB-242084 followed by quipazine ($n = 5$) (* $p < 0.005$, post-hoc LSD Fisher test).

Experiment 7: Effect of serotonergic drugs on the expression of clock genes in the SCN

Fig. 50 shows a representative picture of *rPer1* hybridation in the SCN induced by saline and quipazine (3 mg/kg) injections. Quipazine at 3 mg/kg induced the expression of *rPer1* in the SCN. The animals received injections of either saline, m-CPBG, quipazine at 3 mg/kg or quipazine at 10 mg/kg.

Fig. 51 shows mean mRNA levels of *Per1* and *Per2* induced by these different injections. One-way ANOVA revealed a significant effect of injections on *rPer1* mRNA level ($F_{injections} (3,16) = 5.780, p < 0.05$). Quipazine at 3 mg/kg induced a significant increase of *Per1* mRNA level (166 ± 12.5 min) compared to saline (114.4 ± 9.7 min) ($p < 0.05$). Moreover, the post hoc test indicates that the differences between mRNA levels of *Per1* in animals injected with m-CPBG or with quipazine at 10 mg/kg and animals injected with saline are at the limit of significance with $p = 0.08$ and $p = 0.06$, respectively. However, one-way ANOVA failed to reveal any significant effect of injection on *Per2* (Fig. 51), *Cry1*, *Cry2*, *Bmal1* and *Rev-erb α* (data not shown).

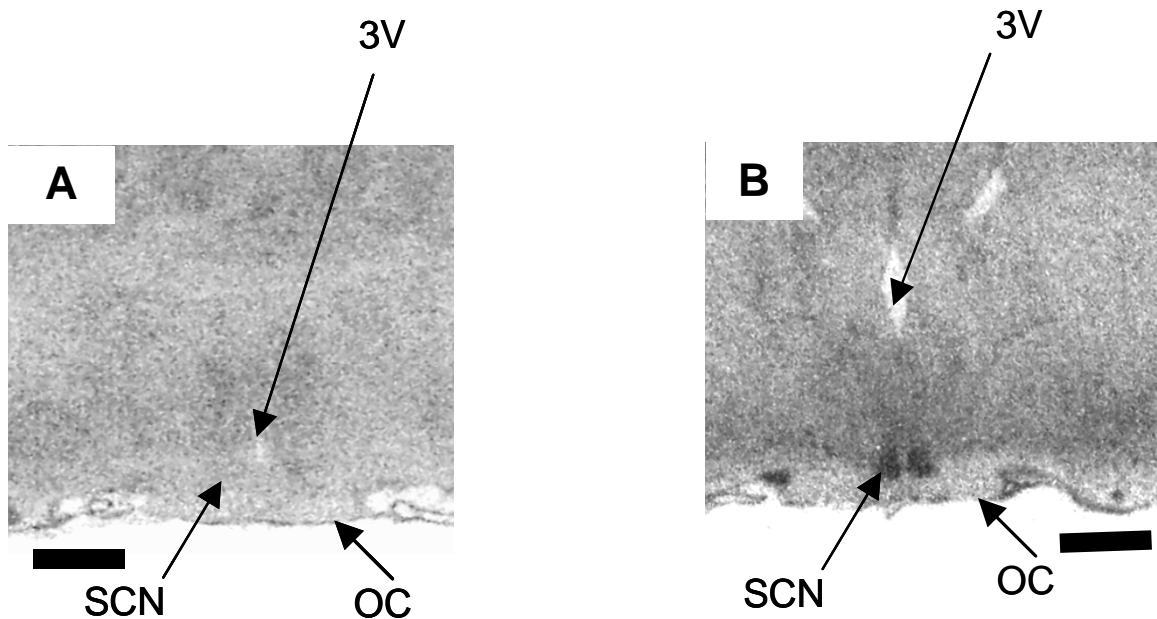

Figure 50. Representative autoradiograms of coronal rat brain sections cut at the SCN level hybridized with *rPer1* riboprobe. Rats were injected at CT 22 with saline (A) or quipazine (3 mg/kg) (B). OC = optic chiasm, 3V = third ventricle. Scale bar = 1 mm.

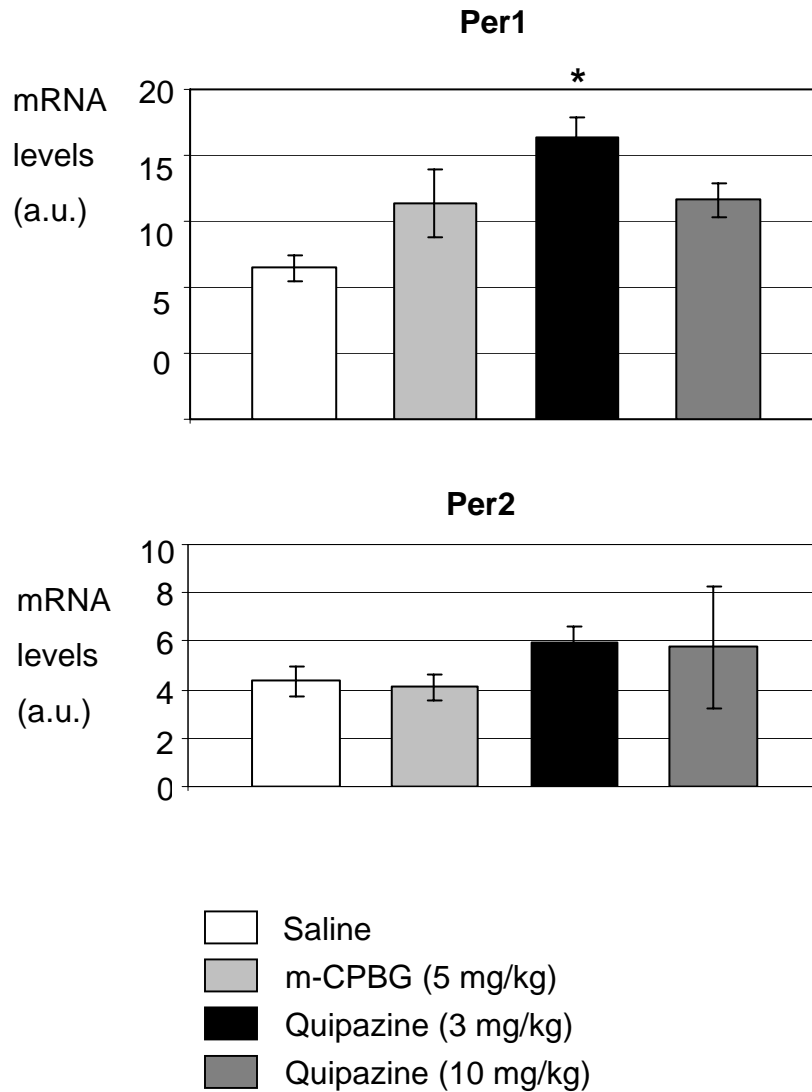

Figure 51. *Per1* and *Per2* expression (means \pm SEM: standard error of mean) in the SCN of rats induced at CT 22 by injections of either saline (s.c.) ($n = 4$), m-CPBG (5 mg/kg, i.p.) ($n = 5$), quipazine (3 mg/kg, s.c.) ($n = 6$) or quipazine (10 mg/kg) ($n = 5$). * $p < 0.05$. Post-hoc used is the LSD Fisher test.

Thus, quipazine was able to induce the expression of *Per1* in the SCN when injected at CT 22. Moreover, m-CPBG tended to increase the expression of *Per1* in the SCN at CT 22. However, neither quipazine nor m-CPBG were able to induce the expression of *Per2*, *Cry1*, *Cry2*, *Bmal1* and *Rev-erba* in the SCN at CT 22.

Discussion

Photic-like effects of quipazine

The present results show photic-like effects of the 5-HT agonist quipazine on locomotor activity rhythm and on c-FOS expression in the SCN, which are consistent with several other studies performed *in vivo* in rats. For example, quipazine, DOI or mCPP have been shown to induce photic-like phase shifts of locomotor activity (Kalkowski and Wollnik, 1999; Kohler *et al.*, 1999; Graff *et al.*, 2005) and c-FOS protein expression in the ventrolateral SCN (Moyer *et al.*, 1997; Kennaway and Moyer, 1998; Kalkowski and Wollnik, 1999; Kohler *et al.*, 1999).

We show in this work that quipazine at CT 22 induces the expression of *Per1*, but not *Per2* as is also the case for light (Albrecht *et al.*, 1997) and has no effect on other clock genes, i.e. *Cry1*, *Cry2*, *Bmal1* and *Rev-erba*. These results may be conflicting with the effects of other 5-HT agonists on *Per1* and *Per2* expression. Indeed, Varcoe *et al.* (2003) showed that DOI induced the expression of *Per1* as well as *Per2* at ZT 16, but had no effects on the expression of these two clock genes at ZT 22. Moreover, they showed that RO 60-0175 ((s)-2-(6-chloro-5-fluoroindol-1-yl)-1-methylethylamine) induced the expression of *Per1* but not *Per2* at ZT16, and failed to induce *Per* genes expression at ZT 22. However, DOI is a specific 5-HT_{2A/2C} agonist and RO 60-0175 is a highly selective 5-HT_{2C} receptor agonist, whereas quipazine is a non-specific 5-HT agonist. Thus, these results provide evidence for an action of quipazine on different 5-HT receptors subtypes compared to these two 5-HT agonists.

In addition, the induction of *Per1* by quipazine is greater at 3 mg/kg compared to 10 mg/kg, consistent with the results obtained on the locomotor activity rhythm. Indeed, the phase advance of the locomotor activity rhythm induced by quipazine injection at 3 mg/kg is slightly higher than that at 10 mg/kg. These results could be explained by the fact that quipazine binding to a wide range of 5-HT receptors is concentration-dependant. Thus, at

higher concentration it can also bind 5-HT receptors, like 5-HT_{1B} receptors, known to have inhibitory effects. The use of the optimal concentration of quipazine should reduce the recruitment of other 5-HT receptor subtypes with lower affinity for quipazine.

Taken together, these results provide additional support for serotonergic control of the pathway conveying photic input to the SCN. This hypothesis is also strengthened by results obtained in enucleated animals (Graff *et al.*, 2005). As mentioned earlier, bilateral enucleation blocks the effect of quipazine on the locomotor activity rhythm and on c-FOS expression in the SCN.

Involvement of the 5-HT₃ receptor in 5-HT photic-like effect on locomotor activity rhythm

The present results obtained with the use of the specific 5-HT₃ agonist, m-CPBG, and the specific 5-HT₃ antagonist, ondansetron, clearly demonstrate the involvement of 5-HT₃ receptor in the photic-like effects of 5-HT agonists on the locomotor activity rhythm at CT 22. Indeed, m-CPBG induced a phase advance of the locomotor activity rhythm and ondansetron was able to block the phase advance induced by quipazine. This is the first time that the 5-HT₃ receptor subtype is shown to be involved in mechanisms of the circadian system. In other brain structures the 5-HT₃ receptor has been well studied (Hoyer *et al.*, 2002), and is known to increase intracellular calcium concentrations in glutamatergic terminals, thereby inducing the release of glutamate (Van Hoof and Vijverberg, 2000). Moreover, we have demonstrated here that the activation of NMDA receptors is necessary for quipazine-induced phase advances of the locomotor activity rhythm, again suggesting the involvement of 5-HT₃ and subsequent glutamate release in the photic-like effect of quipazine on locomotor activity rhythm.

To date, there is no clear demonstration of the presence of the 5-HT₃ receptor in the SCN. Presynaptic receptor mRNA should reside in cell bodies and not in presynaptic terminals, thus 5-HT₃ mRNA should be located in the retinal ganglion cells, but not in the SCN, and vice versa for the protein. Indeed, Roca *et al.* (1993) failed to detect 5-HT₃ receptors in the SCN by *in situ* hybridization that is consistent with a presynaptic localization of the 5-HT₃ receptors. However, previous autoradiography studies using [³H]quipazine failed to demonstrate any 5-HT₃ receptor subtype binding sites in the SCN *in vivo* (Prosser *et al.*, 1993). It will be therefore necessary to undertake 5-HT₃ immunohistology in the SCN, in

order to demonstrate the presence of this receptor subtype on the fiber terminals present in the ventrolateral retinorecipient area of the SCN.

Involvement of the 5-HT₃ receptor in 5-HT photic-like effect on c-FOS and clock gene expression in the SCN

The 5-HT₃ agonist used in this study, m-CPBG, induced c-FOS expression, with a stronger effect in the ventrolateral retinorecipient compared to the dorsomedial region of the SCN. Moreover, the level of c-FOS expression was close to that induced by light. These results reinforce the idea that the 5-HT₃ receptors are involved in 5-HT modulation of the RHT, which terminate in the ventrolateral part of the SCN and that convey light information. Moreover, c-FOS expression induced by mCPBG was higher than that induced by quipazine, furnishing an additional argument for the idea that quipazine can bind to a wide range of 5-HT receptors and then, depending on the dose, stimulate activatory and inhibitory 5-HT receptors. However, the 5-HT₃ antagonist, ondansetron, failed to block the c-FOS expression induced by quipazine. Thus, it seems plausible that the 5-HT₃ receptors are implicated in the c-FOS expression, but in combination with another 5-HT receptor(s) subtype(s). Kennaway and co-workers (2001) based their theory of a postsynaptic 5-HT_{2C} receptor pathway on experimental evidence showing that quipazine effects on the melatonin secretion rhythm can be mimicked by application of specific 5-HT_{2C} agonists such as DOI, mCPP, and TFMPP, while drugs more specific for 5-HT_{1A/7} receptors (e.g. 8-OH-DPAT) could not induce phase shifts at CT 18 (Kennaway and Moyer, 1998). Moreover, they showed that DOI induced c-FOS expression in the SCN when injected at ZT 14, 16, 18, 20 and 22 (Kennaway *et al.*, 2001). In addition, DOI and the highly selective 5-HT_{2C} agonist RO 60-0175 increased both *c-Fos* and *Per* gene expression in the SCN (Varcoe *et al.*, 2003). Furthermore, DOI-induced phase shifts of the melatonin secretion rhythm and c-FOS expression were reduced by the 5-HT_{2C} antagonist SB-242084, as well as the atypical 5-HT_{2C} antagonists methylclozapine and clozapine (Kennaway *et al.*, 2001). Kennaway and co-workers (2001) have thus proposed that 5-HT_{2C} receptors located postsynaptically within the SCN play a role in the transmission of photic information in the rat circadian system. However, in our study, the 5-HT_{2C} antagonist SB-242084, as well as the 5-HT₃ antagonist ondansetron, failed to block the c-FOS expression induced by quipazine. One explanation could thus be that at least at CT 22 and for c-FOS expression induced by 5-HT agonists, the pathways implicating 5-HT₃ and 5-HT_{2C}

receptors subtype work in parallel, and that both pathways need to be inhibited in order to completely block the effect of quipazine on c-FOS expression.

As for the locomotor activity rhythm, MK-801 was able to block the effect of quipazine on c-FOS expression in the SCN. This result is consistent with the idea that quipazine affects the SCN through the 5-HT₃ receptor present at RHT terminals, whose activation induces glutamate release and subsequent NMDA receptor activation. However, since ondansetron alone was not able to block the effect of quipazine on the expression of c-FOS, it seems likely that other 5-HT receptor(s) involved in this effect (most probably the 5-HT_{2C} receptor) also require NMDA receptor activation, as previously hypothesized by Kennaway and co-workers (2001) for the 5-HT_{2C} receptor. Thus, it is possible that MK-801 pretreatment blocks both 5-HT₃ and 5-HT_{2C} simultaneously, thereby prevents c-FOS expression in the SCN induced by 5-HT agonists for these receptor subtypes.

As quipazine and light, m-CPBG is not able to induce expression of the clock genes *Per2*, *Cry1*, *Cry2*, *Bmal1*, *Rev-erba*. However, contrary to quipazine and light, m-CPBG was also not able to induce *Per1* expression in the SCN at CT 22. This results seem to indicate that the 5-HT₃ receptor is not involved in the photic-like effect of 5-HT agonists on clock gene expression, raising the possible implication of other 5-HT receptors in this effect. Additional studies with other 5-HT agonists are therefore require to see which 5-HT receptor subtype(s) implicate in these effects on clock gene expression.

In summary, this study confirms the photic-like effect of 5-HT agonists on locomotor activity rhythm and c-FOS expression, and demonstrates the photic-like effect of 5-HT agonists on *Per1* expression. Moreover, we showed that quipazine effects on locomotor activity rhythm are mediated by 5-HT₃ receptors, whose activation induce glutamate release from the RHT terminals and subsequent NMDA receptors activation. In addition, c-FOS expression induced by 5-HT agonists in the SCN involves activation of 5-HT₃ and additional receptors, 5-HT_{2C} receptor being likely candidates. It would then be necessary to try to block c-FOS expression induced by quipazine by both 5-HT₃ and 5-HT_{2C} specific antagonists in order to confirm this hypothesis. Nevertheless, the NMDA receptors are clearly involved in the serotonergic induction of c-FOS expression, suggesting that the activation of both 5-HT receptors lead to the expression of c-FOS via NMDA receptors activation. Thus, it seems likely that the SCN pathway involved in the locomotor activity rhythm control and that involved in c-FOS expression are not entirely the same. Moreover, the 5-HT receptor

subtype(s) involved in the serotonergic induction of *Per1* expression seems is still unknown. Finally, it will be necessary to clearly prove the presence and presynaptic localization of the 5-HT₃ receptor in the SCN.

Acknowledgements

This research was supported by the “Deutsche Forschungsgemeinschaft”. The plasmids for synthesis of *rPer1* and *rPer2* were generously donated by Dr. Hitoshi Okamura (Kobe University Graduate School of Medicine, Kobe, Japan). We would like to thank Dr. Hugues Dardente for kindly providing the clones of *mCry1*, *mCry2*, *rBmall* and *rRev-erb α* , Angeline Votteler for excellent technical assistance and Dr. David Hicks for English revision.

General discussion and perspectives

GENERAL DISCUSSION AND PERSPECTIVES

The SCN are able to integrate various Zeitgebers in order to be entrained to exactly 24 h. These nuclei thereafter control physiological and behavioral circadian rhythms of the body, such as locomotor activity or food intake rhythm. The environment provides a lot of simultaneous synchronizing cues either photic or non-photic, that the SCN clock has to integrate in order to build an integrated information to the body. However, the mechanisms as well as the neuronal basis of this integration are not yet well known.

I. Interaction between a non-photic cue, the timed caloric restriction, and a photic cue, the LD cycle

I.1. SCN integration

Timed caloric restriction is the only non-photic cue able to compete with the LD cycle in modulating the phase angle of photic synchronization (Challet *et al.*, 1997c, 1998d). In our study, timed caloric restriction was able to phase advance the locomotor activity, melatonin secretion and VP expression rhythm in mice exposed to a LD cycle. Thus, in addition to behavioral and physiological evidences provided by the locomotor activity and melatonin secretion rhythm, the result for the VP mRNA expression rhythm which is a direct molecular clock output, suggests that the integration of these two Zeitgebers is proceeded into the molecular loops of the clock. In the study of clock gene expression, we demonstrated that *Per1* and *Cry2* expression rhythm was phase advanced by a timed caloric restriction in mice placed in a LD cycle.

We confirmed also that behavioral outputs as well as clock and clock-controlled genes expression of light-synchronized SCN are not affected by temporally restricted feeding (Challet *et al.*, 1997c; Damiola *et al.*, 2000; Hara *et al.*, 2001). Thus it seems likely that the timed caloric restriction is able to compete with the LD cycle due more to its hypocaloric nature and not because it is provided during the day. This suggestion is supported by the fact that hypocaloric feeding also induces phase advances of the locomotor activity rhythm when submitted during the night (Challet *et al.*, 1998d). However, temporally restricted feeding like timed caloric restriction, induces the appearance of a bout of activity preceding the time of feeding, named food anticipatory activity (FAA) (Mistlberger, 1994; Stephan, 2002). The

increase of activity and/or the stress induced by the food deprivation could explain the phase advances of the behavioral outputs obtained in caloric restricted animals. Indeed, forced locomotor activity as well as non-photic factors which induce stress in animals, are known to phase advance the locomotor activity during the subjective day (Mrosovsky *et al.*, 1989; Antle and Mistlberger, 2000; Meerlo *et al.*, 2002). However, the FAA is also observed in normocaloric-fed animals but without inducing phase advances. Moreover, an immobilisation of the animals during the time of FAA, thus preventing them to run during the day, do not block the phase shifting effects of hypocaloric-fed animals (Challet *et al.*, 1998d). The implication of diurnal activity being excluded in these phase advances, stress obtained during FAA and also during immobilisation, could be the factor responsible for the phase shifting effects of timed caloric restriction under LD cycle. This hypothesis was discarded since a daily stress applied to animals fed *ad libitum* and exposed to a LD cycle (Challet *et al.*, 1998d) did not result in any phase advances of the locomotor activity.

In addition, the phase shifting effects of the interaction between hypocaloric feeding and LD cycle on clock genes expression rhythm are totally different from those of other known non-photic cues. Indeed, non-photic cues like forced running activity, induce a decrease of *Per1* and *Per2* expression when submitted during the day (Maywood *et al.*, 1999; Yannielli *et al.*, 2002). In contrast, we showed that the interaction between timed caloric restriction and LD cycle results in an advance of the expression rhythm of *Per1* and *Cry2* and has no effect on the expression of *Per2* and *Bmal1*. The effect of this interaction leads thus to an impairment of the phase-relationship between the clock genes studied as well as between clock genes and clock outputs already observed in several jet lag studies (Reddy *et al.*, 2002; Nagano *et al.*, 2003; Vansteensel *et al.*, 2003). In conclusion, these results provide a further argument toward a marked difference between the acute effects of the classical non-photic cues and the chronic effects of the timed caloric restriction.

It seems thus likely that the timed caloric restriction is the only non-photic cue able to modulate the photic synchronization of the SCN due to its metabolic nature. This cue cannot therefore be considered as a “classical” non-photic factor having an acute effect during the day. Conversely, timed caloric restriction is not dependent on the circadian time of application and has most probably chronic effects. Moreover, we have demonstrated that the integration of this atypical non-photic cue with the LD cycle is achieved by the SCN, in the molecular loops responsible for the circadian rhythms generation.

But how is the interaction between these photic and non-photoc factors integrated in the SCN?

I.2. Light entrainment modulation

We showed in the first study that the PRC to light is deeply modified by the interaction between the LD cycle and the timed caloric restriction. More precisely, the phase advances at the end of the subjective night are strongly increased while the phase delays are not significantly modified. Moreover, light which is known not to induce any phase shifts during the subjective day in *ad libitum* animals, induced in hypocaloric-fed mice a small, but significant phase advance. Thus the SCN seem to be more sensitive to light in restricted animals. These results could thus explain the higher light-induced phase advances of the locomotor activity rhythm resulting in changed a phase angle of photic synchronization. This reinforces the idea that timed caloric restriction is atypical compared to other more classical non-photoc cues. Indeed, non-photoc cues have been shown to decrease, rather than increase, the light responses of the SCN. For example, forced locomotor activity (Ralph and Mrosovsky, 1992; Mistlberger and Antle, 1998) as well as stress (Meerlo *et al.*, 1997; Challet *et al.*, 2001) are known to decrease light responses of behavioral circadian outputs.

In addition, our results showed that the light-induced expression of *Per1* and *Per2* was changed by the interaction between hypocaloric feeding and LD cycle. The light induction of *Per1* expression was decreased over the entire night while light-induced *Per2* expression was increased at the beginning of the night. As light has been shown to induce differentially *Per1* and *Per2* expression depending on the time of the night, i.e. light induced the expression of both genes at the beginning but only *Per1* at the end of the subjective night (Albrecht *et al.*, 1997; Shigeyoshi *et al.*, 1997), it is assumed that these two genes play different functions in the synchronization of the SCN clock. Thus, it is not surprising that timed caloric restriction and LD cycle interaction differentially modified the light induction of *Per1* and *Per2* depending on night time. However, since the light-induced phase advances of locomotor activity rhythm were increased at the end of the night, one would expect, at this time, to obtain increased light-induced *Per1* expression in hypocaloric-fed mice. In fact, light-induced *Per1* expression was decreased in these mice and no difference was observed for the light induction expression of *Per2*. In addition, since the light-induced phase delay of locomotor

activity rhythm was not modified, one would expect, at this time, to have no modification of light-induced *Per* expression. On the contrary, at the beginning of the subjective night, light induction of *Per1* expression is decreased and light induction of *Per2* expression is increased.

In contrast, the light suppression of melatonin secretion during the night was not affected by the interaction between timed caloric restriction and LD cycle. Thus, this interaction modified the light induction of the expression of *Per1* and *Per2* without changing the light suppression of melatonin secretion. These two parameters have also been differentially affected in hamsters exposed to a LP and pretreated with various glutamate receptors antagonists (Paul *et al.*, 2003). It was then suggested that two different neurochemical cascades regulated the effects of light on the levels of *Per1* mRNA and pineal melatonin.

Thus, the interaction between timed caloric restriction and LD cycle seems to alter the light responses of the locomotor activity rhythm by an increase of the light sensitivity of the SCN clock. However, the effect of this interaction on light induction of *Per1* and *Per2* expression requires more studies to be elucidated.

But what is the neuronal basis of this modulation of SCN light responses?

I.3. A possible role of 5-HT system

We showed in the first study that timed caloric restriction induces a constant reduction of plasmatic glucose concentration. Moreover, it has been demonstrated that the SCN contain glucose sensitive neurons which phase shifted their neuronal firing rhythm in response to *in vitro* glucose application (Hall *et al.*, 1997). However, reduced glucose availability attenuates circadian responses to light on locomotor activity rhythm, i.e. it decreases mostly phase delays induced by light (Challet *et al.*, 1999). Since in our study, the interaction between timed caloric restriction and LD cycle increased rather than decreased the light-induced phase advances and did not modify the light-induced phase delays, glucose availability is probably not the chronobiotic signal mediating these effects, at least during late night.

Leptin is a possible candidate since this hormone is secreted from adipose tissue during the night in rodents fed *ad libitum* (Ahima *et al.*, 1998; Kalsbeek *et al.*, 2001) and shows short-term changes according to feeding conditions (Ahima *et al.*, 1998; Dallongeville *et al.*,

1998). Specifically, in food-restricted rodents, plasma leptin rises only after mealtime (Martinez-Merlos *et al.*, 2004). Furthermore, leptin has the ability to induce phase advances of the SCN clock *in vitro* (Prosser and Bergeron, 2003) and leptin receptors have been shown to be present in the SCN (Guan *et al.*, 1997). However, phase advances were induced *in vitro* at all circadian times except at late subjective night. Since the interaction between restricted feeding and LD cycle increases the light-induced phase advances at the end of the subjective night, leptin cannot be considered as the molecule mediating these effects.

Another molecule that could be involved in the interaction between these two cues, is 5-HT. Indeed, acute and long-term application of food restriction as well as fasting have been shown to increase brain 5-HT metabolism. For example, these treatments increase brain tryptophan (Kantak *et al.*, 1978; Kohsaka *et al.*, 1980) and brain 5-HT concentrations (Curzon *et al.*, 1972; Kantak *et al.*, 1978) as well as hypothalamic 5-HT concentrations (Fuenmayor and Garcia, 1984; Schweiger *et al.*, 1989). These events are correlated with an increase of 5-HT release, measured by 5-HIAA levels (Curzon *et al.*, 1972; Fuenmayor and Garcia, 1984; Kohsaka *et al.*, 1980; Schweiger *et al.*, 1989). In addition, the density of the 5-HT transporters (Zhou *et al.*, 1996; Huether *et al.*, 1997) as well as the 5-HT_{1B} sensitivity are lower in the food-restricted animals (Gur *et al.*, 2003), both leading to the increase of 5-HT in the synapse. But most of all, the lesion of the 5-HT afferences of the SCN with the specific neurotoxin, 5,7-DHT, is able to reduce the phase advances of the locomotor activity and body temperature rhythm induced by this interaction, thus demonstrating the central role of 5-HT in this process. Interestingly, 5-HT agonists in rats have been shown to induce photic-like shifting effects on the locomotor activity rhythm as well as on c-FOS and clock genes expression in the SCN (Kennaway *et al.*, 1996; Moyer *et al.*, 1997; Kennaway and Moyer, 1998, 1999; Varcoe *et al.*, 2003). More precisely for the locomotor activity rhythm, the injection of 5-HT agonists results in phase delays at the beginning and phase advances at the end of the subjective night (Kohler *et al.*, 1999). Moreover, the light-induced c-FOS expression in the SCN is reduced after 5-HT depletion (Moyer and Kennaway, 2000) indicating that 5-HT could increase the effects of light on the SCN. Thus, the larger light sensitivity obtained at the end of the subjective night in hypocaloric-fed animals could be explained by a higher 5-HT level in the SCN.

But the neuronal mechanisms of 5-HT-induced potentiation of light sensitivity in the SCN are not yet characterized.

We thus decided to explore this issue in studying the photic-like resetting effects of 5-HT agonists in rats.

II. Neuronal mechanisms of photic-like resetting effects of 5-HT agonists in rats

II.1. Localization of the 5-HT receptor(s) involved

Our results confirmed that quipazine, a non-specific 5-HT agonist, induces photic-like effects on the locomotor activity rhythm (Kennaway *et al.*, 1996; Kohler *et al.*, 1999). These photic-like effects were also shown on melatonin secretion rhythm with DOI or mCPP, two specific 5-HT_{2A/2C} and 5-HT_{2C} receptor agonists, respectively (Kennaway, 1997; Kennaway and Moyer, 1998; Kennaway *et al.*, 2001). In addition, our results demonstrated the quipazine-induction of c-FOS expression at CT 22 in the SCN, thus corroborating previous studies showing similar effects with quipazine and DOI (Moyer *et al.*, 1997; Kennaway and Moyer, 1998; Kohler *et al.*, 1999).

We also showed that an enucleation, leading to a degeneration of the RHT, altered the photic-like effects while a degeneration of the GHT or the 5-HT input had no effect. Thus, 5-HT receptors that mediate the resetting effects of quipazine in rats are most likely located on RHT terminals. Our results are clearly in accordance with the finding that quipazine acts into the SCN (Kalkowski and Wollnik, 1999) and could thus explain the strong differences obtained between 5-HT agonists effects in rats *in vivo* and *in vitro* on SCN slices. Indeed, *in vitro* administration of quipazine induces non-photic-like effects, i.e. it leads to phase advances of the electrical activity rhythm when applied during the subjective day (Prosser *et al.*, 1990, 1993) and does not induce c-Fos expression in the SCN when applied during the night (Prosser *et al.*, 1994b). The impairment of the RHT due to optic nerve cut during SCN slice preparation, could lead to an alteration of its responses to presynaptic 5-HT receptors activation. One could then propose that the non-photic-like effects would be induced by the activation of other 5-HT receptors subtypes located on SCN cells.

However, we cannot totally exclude the involvement of 5-HT postsynaptic receptors in the photic-like shifting effects of 5-HT agonists, because it is quite possible that an enucleation can down-regulate the expression of 5-HT postsynaptic receptors. Indeed, it has been shown that enucleation leads to SCN morphological changes, i.e. an increase in

postsynaptic density material (Guldner and Ingham, 1980) and a decrease in GFAP level in the SCN as well as tau changes (Yamazaki *et al.*, 2002). Enucleation and subsequent RHT degeneration seems to have an effect on the SCN and thus could have repercussions on 5-HT postsynaptic receptors density. However, until now, it has only been shown that specific neurotoxic lesions of the 5-HT terminals in the SCN result in an up-regulation of 5-HT_{1B} binding sites (Manrique *et al.*, 1994). There is thus no direct evidence of a post-lesional down-regulation of 5-HT postsynaptic receptors in the SCN.

The subtype of the 5-HT receptor located on the RHT and involved in these 5-HT agonists effects is however unknown.

II.2. Subtype of the 5-HT receptor involved

We tested the possible involvement of the 5-HT₃ receptors in the photic-like effects of quipazine on three parameters: locomotor activity rhythm, c-FOS and clock gene expression in the SCN.

We showed that the injection of m-CPBG, a specific 5-HT₃ agonist, at CT 22 induced phase advances of the locomotor activity rhythm as induced by light. Moreover, the pretreatment of the animals with ondansetron, a specific 5-HT₃ antagonist, before quipazine injection prevented these phase advances. We thus can conclude that the 5-HT₃ receptors are necessary and sufficient to mediate the photic-like effects of quipazine on the locomotor activity rhythm.

At CT 22, c-FOS expression in the SCN was induced by m-CPBG, but the pretreatment with ondansetron before quipazine injections was not able to block this expression. Thus, it appears likely that the 5-HT₃ receptors are involved in the photic-like induction by 5-HT agonists of c-FOS expression, but they are not sufficient to explain this effect. Another / other receptor(s) must be implicated.

In addition, we demonstrated that quipazine injection at CT 22 induced only *Per1*, but not *Per2*, *Cry1*, *Cry2*, *Bmal1* and *Rev-erba* expression in the SCN. Interestingly, similar effects were obtained after a LP at CT 22. However, injection of m-CPBG was not able to induce (despite a strong trend) a significant *Per1* expression in the SCN, suggesting the non involvement of the 5-HT₃ receptor in the induction of these clock gene expression, but maybe together with another receptor.

Altogether, our results seem to indicate that the photic-like effects of quipazine are mediated by various 5-HT receptor subtypes depending on the parameter observed. Different responses for various parameters of the clock has also been obtained after jet lag experiments. More precisely, *Per1* expression and locomotor activity rhythm were differently affected in these studies (Nagano *et al.*, 2003; Vanteensel *et al.*, 2003). Furthermore, confinement in a novel-wheel, considered as a non-photic cue, is able to attenuate light-induced phase advances of locomotor activity rhythm, without affecting light induction of c-FOS and *Per1* expression (Edelstein *et al.*, 2003).

Other 5-HT receptor subtypes have been shown to be involved in the photic-like shifting effects of 5-HT agonists. Kennaway and co-workers (1998) demonstrated that application of 5-HT_{2C} agonists such as DOI, mCPP and TFMPP at CT 18, is able to induce phase shifts of the melatonin secretion rhythm, while more specific agonists for 5-HT_{1A/7} receptors (e.g. 8-OH-DPAT) or 5-HT₃ receptors (1-phenybiguanide) are not. Furthermore, this effect of DOI on melatonin secretion rhythm can be suppressed by the pretreatment with the specific 5-HT_{2C} antagonist, SB-242084 as well as with the atypical 5-HT_{2C} antagonists methylclonidine and clonidine. A possible explanation for the differences between this study and ours is that the 5-HT receptor subtypes implicated in the photic-like phase shifting effects of 5-HT on the melatonin secretion and those implicated in these effects on the locomotor activity rhythm, are different. For these two effects, we propose that the 5-HT_{2C} receptors and the 5-HT₃ receptors are respectively involved.

Moreover, 5-HT_{2C} receptors was also proposed by these authors, to be the receptor subtype involved in the 5-HT induction of c-FOS expression in the SCN (Kennaway *et al.*, 2001). Indeed, DOI injected at CT 18 increases the c-FOS expression in the SCN and can be blocked by SB-242084. Thus, the 5-HT_{2C} receptors seem to also mediate 5-HT agonists-induced c-FOS expression in the SCN, at CT 18. However, it is quite possible that c-FOS expression in the SCN neurons could be induced by the activation of the 5-HT₃ receptors and of the 5-HT_{2C} receptors. Indeed, we showed at CT 22, that pretreatment with either ondansetron or SB-242084 did not induce any significant inhibition of the quipazine-induction of c-FOS expression, except a weak tendency, suggesting that at this time, neither the 5-HT₃ nor the 5-HT_{2C} receptor subtype are sufficient to induce alone this effect. We thus propose that both 5-HT receptor subtypes are required to mediate this effect of quipazine.

Clock gene expression was shown to be induced by the activation of the 5-HT_{2C} receptor subtype (Varcoe *et al.*, 2003). In fact, DOI (5-HT_{2A/2C} receptor agonist) injected at

Zeitgeber time (ZT) 16 induced the expression of *Per1* and *Per2*, but had no effect on these two clock genes at ZT 22. Moreover, RO 60-0175 induce the expression of *Per1*, but not that of *Per2* at ZT 16 and failed to induce any expression at ZT 22. First, the fact that both agonists do not induce the same effects on these two genes expression, support the evidence of a different specificity for the 5-HT_{2C} receptor. RO 0-0175 being more specific for 5-HT_{2C} receptors than DOI, we can suspect an induction of *Per2* by DOI through another receptor subtype, such as the 5-HT_{2A} receptor. Second, neither DOI nor RO 60-0175 are able to induce *Per1* and *Per2* at ZT 22. Nevertheless, we showed that quipazine, as light, was able to induce the expression of *Per1*, thus demonstrating that 5-HT receptors are involved in this effect. However, at CT 22, the 5-HT_{2C} receptors subtype are not implicated in the quipazine-induction of *Per1* expression and the 5-HT₃ receptor subtype activation only slightly increases *Per1* expression, meaning that it is not sufficient to induce *Per1* expression and that another 5-HT receptor subtype(s) is also implicated in the induction of *Per1* expression by 5-HT at CT 22.

Our results also showed that MK-801, a specific NMDA receptor antagonist, was able to block the phase advances of the locomotor activity rhythm as well as c-FOS expression induction in the SCN at CT 22. This demonstrates the role of the NMDA receptors and thus glutamate release in photic-like resetting effects of quipazine. The activation of the 5-HT₃ receptors is known in other brain structures to induce glutamate release (Ashworth-Preece *et al.*, 1995; Wang *et al.*, 1998; Sevoz-Couche *et al.*, 2002; Funahashi *et al.*, 2004) and subsequent NMDA receptors activation (Reges *et al.*, 2002). Thus, our results provide an additional argument toward an implication of the 5-HT₃ receptors in the phase shifting effects of quipazine on locomotor activity rhythm. However, the pretreatment of the animals with the 5-HT₃ antagonist before the quipazine injection was not able to inhibit the induction of c-FOS expression, suggesting the involvement of another 5-HT receptor subtype. This supposes that the activation of this other 5-HT receptor also leads to glutamate release and subsequent NMDA receptors activation. Indeed, similar results were obtained by Kennaway and co-workers (1999). They showed that the pretreatment with MK-801 can block the phase shifts of the melatonin secretion rhythm as well as the induction of c-FOS expression, induced by DOI. Their hypothesis was that the 5-HT_{2C} receptors are located on SCN neurons, releasing glutamate locally in the SCN in response to their activation (Kennaway *et al.*, 2001). Glutamate then binds to NMDA receptors on other SCN neurons and leads to a photic-like resetting of the clock. This model thus explains how MK-801 is able to block the induction of c-FOS expression induced by the activation of the postsynaptic 5-HT_{2C} receptor. The model

of Kennaway implies that the RHT input as well as the 5-HT afferences from the raphe end on different SCN neurons. This concept however does not fit with available neuroanatomical data obtained by Ibata *et al.* (1989), Tanaka *et al.* (1993) and Bosler and Beaudet (1985) showing a convergence of these two inputs on the same VIP-ir SCN neurons.

Nevertheless, another 5-HT receptor subtype seems also to be involved at CT 22. Indeed, 5-CT injected at CT 22 induces a phase advance of the locomotor activity rhythm as well as c-FOS expression in the SCN (Mullins *et al.*, 1999; Kalkowski, 2000). Moreover, the 5-HT₇ antagonist, ritanserin, is able to block these phase advances (Kalkowski, 2000) and c-FOS expression in the SCN (Mullins *et al.*, 1999). Thus, the 5-HT₇ receptor could also be part of the model despite a lack of clear evidence of its localization.

II.3. A proposition of model for the photic-like resetting effects of 5-HT

The model, represented on Figure 52, is based on the following conclusions:

- * Various 5-HT receptor subtypes are involved in the photic-like shifting effects of 5-HT agonists.
- * Since specific antagonists are able to block differentially the photic-like effects of 5-HT agonists depending on the parameter considered, we suppose that different output parameters are controlled by different network of SCN neurons, bearing different 5-HT receptor subtypes.
- * The 5-HT₃ receptors, most likely presynaptic and localized on RHT terminals, are sufficient to mediate the photic-like resetting effects of 5-HT on locomotor activity rhythm, but seem to be not involved in shifting effects on the melatonin secretion rhythm.
- * In contrast, the 5-HT_{2C} receptors, postsynaptic and localized on SCN neurons, seem to be not involved in the photic-like resetting effects of 5-HT on locomotor activity rhythm, but are sufficient to mediate the photic-like resetting effects of 5-HT on melatonin secretion rhythm.
- * Both 5-HT₃ and 5-HT_{2C} receptors participate in the 5-HT-induction of c-FOS expression.
- * NMDA receptors are involved in the photic-like shifting effects of 5-HT agonists on both output parameters and on the induction of c-FOS expression by 5-HT agonists.

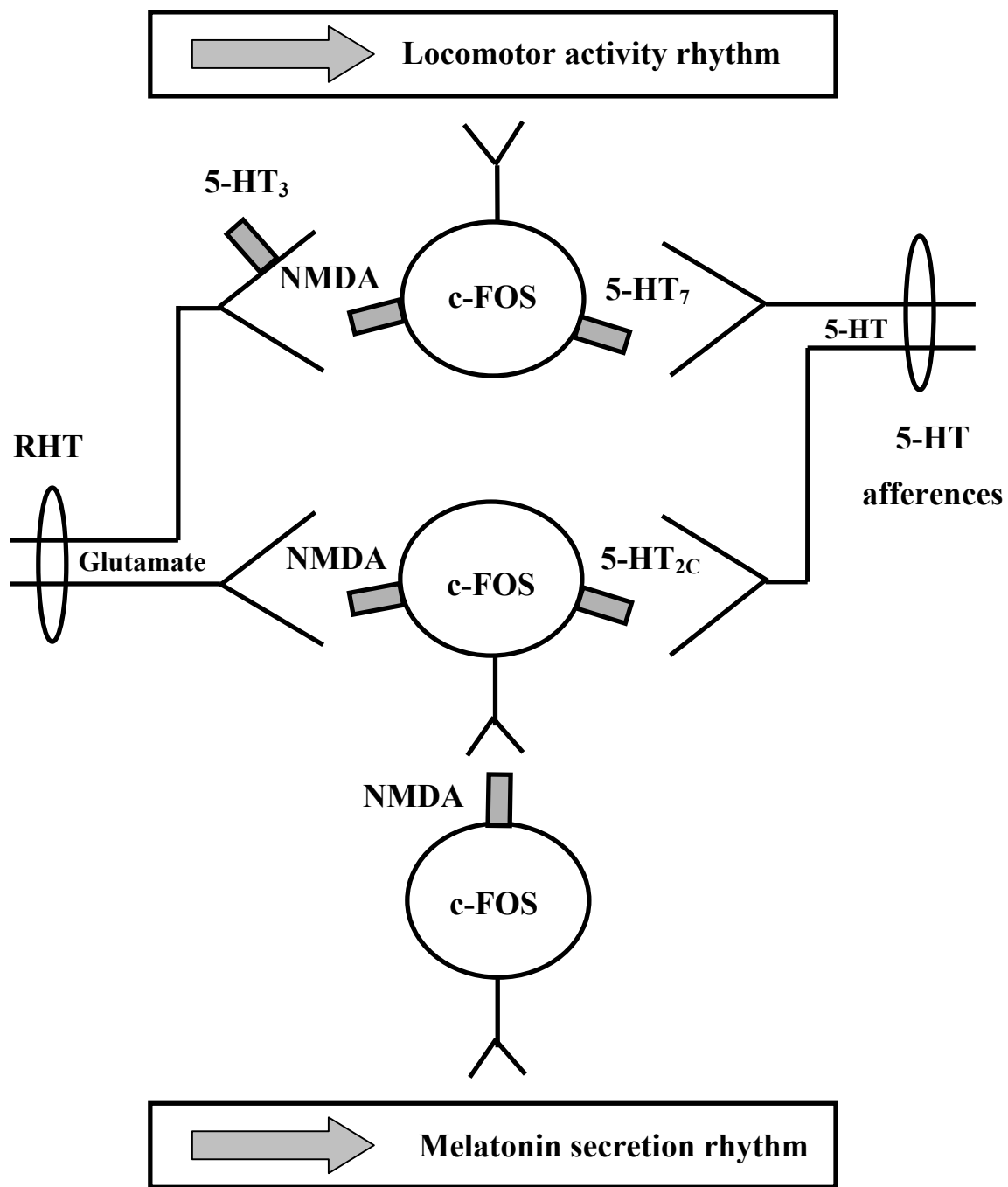

Figure 52. Model proposed for the photic-like resetting effects of 5-HT at CT 22

- * The 5-HT₇ receptors may play a role in the photic-like resetting effects of 5-HT agonists on the locomotor activity rhythm and on c-FOS expression.

One of the main characteristics of this model is that the circadian control of the locomotor activity and melatonin secretion is provided by two different networks of SCN neurons. Since this hypothesis is based on results obtained from different studies, it will be necessary to test the effect of 5-HT agonists on these two parameters in the same study. Moreover, it will be interesting to try to block differentially the effect of 5-HT agonists on those parameters with specific 5-HT antagonists, for example 5-HT₃ or 5-HT_{2C} receptor antagonists.

Despite a presynaptic localization of the 5-HT₃ receptors in other various brain structures (Van Hooft and Vijverberg, 2000), a clear demonstration of the presence and the presynaptic localization of the 5-HT₃ receptors in the SCN is still lacking. It will therefore be necessary to proceed to 5-HT₃ immunohistology, in order to prove the presence of the 5-HT₃ receptor subtype in the SCN and to show its presynaptic localization. Unfortunately, the only 5-HT₃ receptor antibody available seems to be not specific enough to obtain clear conclusions (Mazzia *et al.*, 2003).

In addition, enucleation leading to the RHT degeneration, induced an impairment of the phase shifting effects of quipazine on the locomotor activity due to the loss of the 5-HT₃ receptors activation and subsequently NMDA receptor activation. However, enucleation was also able to block quipazine-induced c-FOS expression. We can then assume that the other 5-HT receptors involved in this induction is also impaired after the RHT degeneration most likely through a down-regulation of their expression. In order to know whether both 5-HT₃ and 5-HT_{2C} receptor subtypes are involved in the quipazine-induction of c-FOS expression of the SCN, it will be necessary to assess the effect of a pretreatment combining both specific 5-HT₃ and 5-HT_{2C} antagonists.

Nevertheless, this model has been built mostly with results obtained at CT 22. At other CTs, it is possible that other 5-HT receptor subtypes are involved. It will thus be interesting to follow over 24 h, the 5-HT₃ as well as the 5-HT_{2C} receptor density and expression, in order to find out a possible circadian regulation of 5-HT receptors expression. This could explain the variation of amplitude of the DOI-induced c-FOS expression throughout the day (Kennaway *et al.*, 2001).

Moreover, since 5-HT agonists in other species such as hamsters or mice, have different resetting properties on the clock, our model is restricted to the rat. The differences found between these species could be explained by the variation and even a lack of expression of certain 5-HT receptors subtype. It will thus be important to compare circadian pattern of expression of these 5-HT receptor subtypes in various species.

III. Conclusion and perspectives

Taken together, our results have highlighted a modulation of the light sensitivity of the SCN by the interaction between timed caloric restriction and LD cycle. This interaction seems to be integrated at the level of the SCN through the action of 5-HT, released by the 5-HT input coming from the raphe nuclei. At CT 22, 5-HT released from the 5-HT fibers can then bind to several 5-HT receptors available at this time. The 5-HT₃ receptors seem to be involved in the modulation of the light input to the SCN and more precisely on the locomotor activity rhythm. However, other 5-HT receptors could also be responsible for the resetting effects of 5-HT on other parameters of the clock.

Nevertheless, it is necessary to verify whether the 5-HT release rhythm in the SCN is modified by the interaction between timed caloric restriction and LD cycle. This could be checked by using 5-HT microdialysis technique in the SCN over 24 h, in rats exposed to a LD cycle and submitted to hypocaloric feeding. Moreover, the injection of 5-HT₃ as well as NMDA antagonists at the time of the 5-HT peak in restricted animals, could provide more evidence for the implication of the 5-HT₃ receptor. In addition, daily injections of a 5-HT₃ agonist could be used to mimic the 5-HT release in rats bearing a lesion of the 5-HT input. If this treatment leads to phase changes as those observed during timed caloric restriction, this would give a strong argument toward an implication of the 5-HT₃ in the modulation of clock light sensitivity by timed caloric restriction in LD cycle.

Nevertheless, the 5-HT system seems to be not the only system involved in these resetting effects of the interaction between timed caloric restriction and LD cycle. Indeed, we demonstrated that this interaction induces a phase advance of *Per1* and *Cry2* expression rhythm while a quipazine injection, tested at CT 22, has only an effect on the expression of *Per1*. NPY release from the GHT could also be involved in these effects since the IGL lesion leading to the GHT degeneration, is able to reduce phase advances of the locomotor activity rhythm induced by the combination of hypocaloric feeding and LD cycle (Challet *et al.*,

1996b). In addition, glucose or leptine levels could also contribute to mediate these effects. Indeed, it has been shown that SCN contain glucose sensitive neurons (Hall *et al.*, 1997). Moreover, reduced glucose availability is known to decrease the light sensitivity of the clock mostly at the beginning of the subjective night (Challet *et al.*, 1999). Leptin has also chronobiotic effects on the clock, inducing phase advances of the clock during the day and the beginning of the subjective night (Prosser and Bergeron, 2003). Thus, combination of the effects of these molecules could explain the effects of interaction between timed caloric restriction and LD cycle.

In conclusion, when animals live in their natural environment, they can be exposed to extreme conditions such as drastic reduction in food availability, for example during wintertime. Their clock then receives feedback information from periphery that helps them to cope with these environmental changes. This information, most likely conveyed by several neuronal systems, like the 5-HT system, modulates the light sensitivity of the circadian clock. For this, the 5-HT system uses a large range of 5-HT receptors to accurately influence the functioning of the clock.

References

REFERENCES

A

- Abe H, Honma S, Namihira M, Tanahashi Y, Ikeda M, Honma KI (1998) Circadian rhythm and light responsiveness of BMAL1 expression, a partner of mammalian clock gene Clock, in the suprachiasmatic nucleus of rats. *Neurosci Lett.* 258:93-96.
- Aghajanian GK, Vandermaelen CP (1982) Intracellular recordings from serotonergic dorsal raphe neurons: pacemaker potentials and the effect of LSD. *Brain Res.* 238:463-9.
- Aguilar-Roblero R, Shibata S, Speh JC, Drucker-Colin R, Moore RY (1992) Morphological and functional development of the suprachiasmatic nucleus in transplanted fetal hypothalamus. *Brain Res.* 580:288-96.
- Aguilar-Roblero R, Verduzco-Carbajal L, Rodriguez C, Mendez-Franco J, Moran J, de la Mora MP (1993) Circadian rhythmicity in the GABAergic system in the suprachiasmatic nuclei of the rat. *Neurosci Lett.* 157:199-202.
- Aguilar-Roblero R, Morin LP, Moore RY (1994) Morphological correlates of circadian rhythm restoration induced by transplantation of the suprachiasmatic nucleus in hamsters. *Exp Neurol.* 130:250-60.
- Ahima RS, Prabakaran D, Flier JS (1998) Postnatal leptin surge and regulation of circadian rhythm of leptin by feeding. Implications for energy homeostasis and neuroendocrine function. *J Clin Invest.* 101:1020-7.
- Akashi M, Tsuchiya Y, Yoshino T, Nishida E (2002) Control of intracellular dynamics of mammalian period proteins by casein kinase I epsilon (CKIepsilon) and CKIdelta in cultured cells. *Mol Cell Biol.* 22:1693-703.
- Akiyama M, Kouzu Y, Takahashi S, Wakamatsu H, Moriya T, Maetani M, Watanabe S, Tei H, Sakaki Y, Shibata S (1999) Inhibition of light- or glutamate-induced mPer1 expression represses the phase shifts into the mouse circadian locomotor and suprachiasmatic firing rhythms. *J Neurosci.* 19:1115-21.
- Albrecht P, Bittner JJ, Halberg F, Visscher MB (1956) Daily changes in 5-hydroxytryptamine concentration in mouse brain. *Proc Soc Exp Biol Med.* 92:703-6.
- Albrecht U, Sun ZS, Eichele G, Lee CC (1997) A differential response of two putative mammalian circadian regulators, mper1 and mper2, to light. *Cell* 91:1055-64.
- Albrecht U, Zheng B, Larkin D, Sun ZS, Lee CC (2001) MPer1 and mper2 are essential for normal resetting of the circadian clock. *J Biol Rhythms* 16:100-4.
- Amir S, Robinson B, Ratovitski T, Rea MA, Stewart J, Simantov R (1998) A role for serotonin in the circadian system revealed by the distribution of serotonin transporter and light-induced Fos immunoreactivity in the suprachiasmatic nucleus and intergeniculate leaflet. *Neuroscience* 84:1059-73.
- Antle MC, Mistlberger RE (2000) Circadian clock resetting by sleep deprivation without exercise in the Syrian hamster. *J Neurosci.* 20:9326-32.
- Antle MC, Ogilvie MD, Pickard GE, Mistlberger RE (2003) Response of the mouse circadian system to serotonin 1A/2/7 agonists in vivo: surprisingly little. *J Biol Rhythms* 18:145-58.
- Armstrong SM, Redman J (1985) Melatonin administration: effects on rodent circadian rhythms. *Ciba Found Symp.* 117:188-207.
- Aronin N, Sagar SM, Sharp FR, Schwartz WJ (1990) Light regulates expression of a Fos-related protein in rat suprachiasmatic nuclei. *Proc Natl Acad Sci U S A* 87:5959-62.
- Aschoff J (1959) Periodik licht- und dunkelaktiver Tiere unter konstanten Umgebungsbedingungen. *Pflügers Archiv*, 270:9.
- Ashcroft GW, Eccleston D, Crawford TB (1965) 5-hydroxyindole metabolism in rat brain. A study of intermediate metabolism using the technique of tryptophan loading. I. Methods. *J Neurochem.* 12:483-92.
- Ashworth-Preece MA, Jarrott B, Lawrence AJ (1995) 5-Hydroxytryptamine₃ receptor modulation of excitatory amino acid release in the rat nucleus tractus solitarius. *Neurosci Lett.* 191:75-8.
- Aton SJ, Colwell CS, Harmar AJ, Waschek J, Herzog ED (2005) Vasoactive intestinal polypeptide mediates circadian rhythmicity and synchrony in mammalian clock neurons. *Nat Neurosci.* 8:476-83.
- Azmitia E, Gannon P (1983) The ultrastructural localization of serotonin immunoreactivity in myelinated and unmyelinated axons within the medial forebrain bundle of rat and monkey. *J Neurosci.* 3:2083-90.
- Azmitia EC, Segal M (1978) An autoradiographic analysis of the differential ascending projections of the dorsal and median raphe nuclei in the rat. *J Comp Neurol.* 179:641-67.
- Azmitia EC, Liao B, Chen YS (1993) Increase of tryptophan hydroxylase enzyme protein by dexamethasone in adrenalectomized rat midbrain.

Increase of tryptophan hydroxylase enzyme protein by dexamethasone in adrenalectomized rat midbrain. *J Neurosci.* 13:5041-55.

B

Bae K, Jin X, Maywood ES, Hastings MH, Reppert SM, Weaver DR (2001) Differential functions of mPer1, mPer2, and mPer3 in the SCN circadian clock. *Neuron* 30:525-36.

Balsalobre A (2002) Clock genes in mammalian peripheral tissues. *Cell Tissue Res.* 309:193-9.

Barassin S, Raison S, Saboureau M, Bienvenu C, Maitre M, Malan A, Pevet P (2002) Circadian tryptophan hydroxylase levels and serotonin release in the suprachiasmatic nucleus of the rat. *Eur J Neurosci.* 15:833-40.

Barbour B, Szatkowski M, Ingledeu N, Attwell D (1989) Arachidonic acid induces a prolonged inhibition of glutamate uptake into glial cells. *Nature* 342:918-20.

Berson DM, Dunn FA, Takao M (2002) Phototransduction by retinal ganglion cells that set the circadian clock. *Science* 295:1070-3.

Biello SM (1995) Enhanced photic phase shifting after treatment with antiserum to neuropeptide Y. *Brain Res.* 673:25-9.

Biello SM, Mrosovsky N (1995) Blocking the phase-shifting effect of neuropeptide Y with light. *Proc Biol Sci.* 259:179-87.

Biello SM, Janik D, Mrosovsky N (1994) Neuropeptide Y and behaviorally induced phase shifts. *Neuroscience* 62:273-9.

Biello SM, Golombek DA, Harrington ME (1997) Neuropeptide Y and glutamate block each other's phase shifts in the suprachiasmatic nucleus in vitro. *Neuroscience* 77:1049-57.

Björklund A, Baumgarten HG, Rensch A (1975) 5,7-Dihydroxytryptamine: improvement of its selectivity for serotonin neurons in the CNS by pretreatment with desipramine. *J Neurochem.* 24:833-5.

Blier P, Pineyro G, el Mansari M, Bergeron R, de Montigny C (1998) Role of somatodendritic 5-HT autoreceptors in modulating 5-HT neurotransmission. *Ann N Y Acad Sci.* 861:204-16.

Block CH, Santos RA, Brosnihan KB, Ferrario CM (1988) Immunocytochemical localization of angiotensin-(1-7) in the rat forebrain. *Peptides* 9:1395-401.

Blondel O, Vandecasteele G, Gastineau M, Leclerc S, Dahmoune Y, Langlois M, Fischmeister R (1997) Molecular and functional characterization of a 5-HT₄ receptor cloned from human atrium. *FEBS Lett.* 412:465-74.

Boadle-Biber MC (1993) Regulation of serotonin synthesis. *Prog Biophys Mol Biol.* 60:1-15.

Bobrzynska KJ, Vrang N, Mrosovsky N (1996) Persistence of nonphotic phase shifts in hamsters after serotonin depletion in the suprachiasmatic nucleus. *Brain Res.* 741:205-14.

Boer GJ, van Esseveldt KE, van der Geest BA, Duindam H, Rietveld WJ (1999) Vasopressin-deficient suprachiasmatic nucleus grafts re-instate circadian rhythmicity in suprachiasmatic nucleus-lesioned arrhythmic rats. *Neuroscience* 89:375-85.

Boess FG, Martin IL (1994) Molecular biology of 5-HT receptors. *Neuropharmacology* 33:275-317.

Boess FG, Beroukhim R, Martin IL (1995) Ultrastructure of the 5-hydroxytryptamine₃ receptor. *J Neurochem.* 64:1401-5.

Bonhaus DW, Loury DN, Jakeman LB, Hsu SA, To ZP, Leung E, Zeitung KD, Eglen RM, Wong EH (1994) [3H]RS-23597-190, a potent 5-hydroxytryptamine₄ antagonist labels sigma-1 but not sigma-2 binding sites in guinea pig brain. *J Pharmacol Exp Ther.* 271:484-93.

Bos NP, Mirmiran M (1990) Circadian rhythms in spontaneous neuronal discharges of the cultured suprachiasmatic nucleus. *Brain Res.* 511:158-62.

Boschert U, Amara DA, Segu L, Hen R (1994) The mouse 5-hydroxytryptamine_{1B} receptor is localized predominantly on axon terminals. *Neuroscience* 58:167-82.

Bosler O, Beaudet A (1985) VIP neurons as prime synaptic targets for serotonin afferents in rat suprachiasmatic nucleus: a combined radioautographic and immunocytochemical study. *J Neurocytol.* 14:749-63.

Breder CD, Yamada Y, Yasuda K, Seino S, Saper CB, Bell GI (1992) Differential expression of somatostatin receptor subtypes in brain. *J Neurosci.* 12:3920-34.

Brewer JM, Yannielli PC, Harrington ME (2002) Neuropeptide Y differentially suppresses per1 and per2 mRNA induced by light in the suprachiasmatic nuclei of the golden hamster. *J Biol Rhythms* 17:28-39.

Brown SA, Zimbrunn G, Fleury-Olela F, Preitner N, Schibler U (2002) Rhythms of mammalian body temperature can sustain peripheral circadian clocks. *Curr Biol.* 12:1574-83.

Bucht G, Adolfsson R, Gottfries CG, Roos BE, Winblad B (1981) Distribution of 5-hydroxytryptamine and 5-hydroxyindoleacetic acid in human brain in relation to age, drug influence, agonal status and circadian variation. *J Neural Transm.* 51:185-203.

Buijs RM (1996) The anatomical basis for the expression of circadian rhythms: the efferent projections of the suprachiasmatic nucleus. *Prog Brain Res.* 111:229-40.

Buijs RM, Wortel J, Hou YX (1995) Colocalization of gamma-aminobutyric acid with vasopressin, vasoactive intestinal peptide, and somatostatin in the rat suprachiasmatic nucleus. *J Comp Neurol.* 358:343-52.

Buijs RM, Hermes MH, Kalsbeek A (1998) The suprachiasmatic nucleus-paraventricular nucleus interactions: a bridge to the neuroendocrine and autonomic nervous system. *Prog Brain Res.* 119:365-82.

Buijs RM, Wortel J, Van Heerikhuizen JJ, Feenstra MG, Ter Horst GJ, Romijn HJ, Kalsbeek A (1999) Anatomical and functional demonstration of a multisynaptic suprachiasmatic nucleus adrenal (cortex) pathway. *Eur J Neurosci.* 11:1535-44.

Bult A, Hiestand L, Van der Zee EA, Lynch CB (1993) Circadian rhythms differ between selected mouse lines: a model to study the role of vasopressin neurons in the suprachiasmatic nuclei. *Brain Res Bull.* 32:623-7.

Bunger MK, Wilsbacher LD, Moran SM, Clendenen C, Radcliffe LA, Hogenesch JB, Simon MC, Takahashi JS, Bradfield CA (2000) Mop3 is an essential component of the master circadian pacemaker in mammals. *Cell* 103:1009-17.

Butler MP, Honma S, Fukumoto T, Kawamoto T, Fujimoto K, Noshiro M, Kato Y, Honma K (2004) Dec1 and Dec2 expression is disrupted in the suprachiasmatic nuclei of Clock mutant mice. *J Biol Rhythms* 19:126-34.

Byku M, Gannon RL (2000) Opioid induced non-photoc phase shifts of hamster circadian activity rhythms. *Brain Res.* 873:189-96.

C

Cagampang FR, Yang J, Nakayama Y, Fukuhara C, Inouye ST (1994) Circadian variation of arginine-vasopressin messenger RNA in the rat suprachiasmatic nucleus. *Mol Brain Res.* 24:179-84.

Cagampang FR, Sheward WJ, Harmar AJ, Piggins HD, Coen CW (1998) Circadian changes in the expression of vasoactive intestinal peptide 2 receptor mRNA in the rat suprachiasmatic nuclei. *Mol Brain Res.* 54:108-12.

Caldelas I, Challet E, Saboureaux M, Pevet P (2005) Light and melatonin inhibit in vivo serotonergic phase advances without altering serotonergic-induced decrease of per expression in the hamster suprachiasmatic nucleus. *J Mol Neurosci.* 25:53-63.

Calza L, Giardino L, Zanni M, Velardo A, Parchi P, Marrama P (1990) Daily changes of neuropeptide Y-like immunoreactivity in the suprachiasmatic nucleus of the rat. *Regul Pept.* 27:127-37.

Canteras NS, Simerly RB, Swanson LW (1994) Organization of projections from the ventromedial nucleus of the hypothalamus: a Phaseolus vulgaris-leucoagglutinin study in the rat. *J Comp Neurol.* 348:41-79.

Card JP, Moore RY (1989) Organization of lateral geniculate-hypothalamic connections in the rat. *J Comp Neurol.* 284:135-47.

Card JP, Brecha N, Karten HJ, Moore RY (1981) Immunocytochemical localization of vasoactive intestinal polypeptide-containing cells and processes in the suprachiasmatic nucleus of the rat: light and electron microscopic analysis. *J Neurosci.* 1:1289-1303.

Card JP, Fitzpatrick-McElligott S, Gozes I, Baldino F Jr (1988) Localization of vasopressin-, vasoactive intestinal polypeptide-, peptide histidine isoleucine- and somatostatin-mRNA in rat suprachiasmatic nucleus. *Cell Tissue Res.* 252:307-315.

Carson MJ, Thomas EA, Danielson PE, Sutcliffe JG (1996) The 5HT_{2A} serotonin receptor is expressed predominantly by astrocytes in which it inhibits cAMP accumulation: a mechanism for neuronal suppression of reactive astrocytes. *Glia* 17:317-26.

Cashmore AR, Jarillo JA, Wu YJ, Liu D (1999) Cryptochromes: blue light receptors for plants and animals. *Science* 284:760-5.

Castel M, Belenky M, Cohen S, Ottersen OP, Storm-Mathisen J (1993) Glutamate-like immunoreactivity in retinal terminals of the mouse suprachiasmatic nucleus. *Eur J Neurosci.* 5:368-81.

Cermakian N, Monaco L, Pando MP, Dierich A, Sassone-Corsi P (2001) Altered behavioral rhythms and clock gene expression in mice with a targeted mutation in the Period1 gene. *EMBO J.* 20:3967-74.

Challet E, Pevet P (2003) Interactions between photic and nonphotic stimuli to synchronize the master circadian clock in mammals. *Front Biosci.* 8:s246-57.

Challet E, Malan A, Pevet P (1996a) Daily hypocaloric feeding entrains circadian rhythms of wheel-running and body temperature in rats kept in constant darkness. *Neurosci Lett.* 211:1-4.

Challet E, Pevet P, Malan A (1996b) Intergeniculate leaflet lesion and daily rhythms in food-restricted rats fed during daytime. *Neurosci Lett.* 216:214-8.

Challet E, Pevet P, Malan A (1997a) Effect of prolonged fasting and subsequent refeeding on free-running rhythms of temperature and locomotor activity in rats. *Behav Brain Res.* 84:275-84.

- Challet E, Pevet P, Lakhdar-Ghazal N, Malan A (1997b) Ventromedial nuclei of the hypothalamus are involved in the phase advance of temperature and activity rhythms in food-restricted rats fed during daytime. *Brain Res Bull.* 43:209-18.
- Challet E, Pevet P, Vivien-Roels B, Malan A (1997c) Phase-advanced daily rhythms of melatonin, body temperature, and locomotor activity in food-restricted rats fed during daytime. *J Biol Rhythms* 12:65-79.
- Challet E, Jacob N, Vuillez P, Pevet P, Malan A (1997d) Fos-like immunoreactivity in the circadian timing system of calorie-restricted rats fed at dawn: daily rhythms and light pulse-induced changes. *Brain Res.* 770:228-36.
- Challet E, Pevet P, Malan A (1997e) Lesion of the serotonergic terminals in the suprachiasmatic nuclei limits the phase advance of body temperature rhythm in food-restricted rats fed during daytime. *J Biol Rhythms* 12:235-44.
- Challet E, Naylor E, Metzger JM, MacIntyre DE, Turek FW (1998a) An NK1 receptor antagonist affects the circadian regulation of locomotor activity in golden hamsters. *Brain Res.* 800:32-9.
- Challet E, Bernard DJ, Turek FW (1998b) Lesions of glucose-responsive neurons impair synchronizing effects of calorie restriction in mice. *Brain Res.* 801:244-50.
- Challet E, Scarbrough K, Penev PD, Turek FW (1998c) Roles of suprachiasmatic nuclei and intergeniculate leaflets in mediating the phase-shifting effects of a serotonergic agonist and their photic modulation during subjective day. *J Biol Rhythms* 13:410-21.
- Challet E, Solberg LC, Turek FW (1998d) Entrainment in calorie-restricted mice: conflicting zeitgebers and free-running conditions. *Am J Physiol* 274: R1751-R1761.
- Challet E, Losee-Olson S, Turek FW (1999) Reduced glucose availability attenuates circadian responses to light in mice. *Am J Physiol.* 276:R1063-70.
- Challet E, Turek FW, Laute M, Van Reeth O (2001) Sleep deprivation decreases phase-shift responses of circadian rhythms to light in the mouse: role of serotonergic and metabolic signals. *Brain Res.* 909:81-91.
- Challet E, Poirel VJ, Malan A, Pevet P (2003) Light exposure during daytime modulates expression of *Per1* and *Per2* clock genes in the suprachiasmatic nuclei of mice. *J Neurosci Res.* 72:629-37.
- Chamas FM, Underwood MD, Arango V, Serova L, Kassir SA, Mann JJ, Sabban EL (2004) Immobilization stress elevates tryptophan hydroxylase mRNA and protein in the rat raphe nuclei. *Biol Psychiatry* 55:278-83.
- Chastrette N, Pfaff DW, Gibbs RB (1991) Effects of daytime and nighttime stress on Fos-like immunoreactivity in the paraventricular nucleus of the hypothalamus, the habenula, and the posterior paraventricular nucleus of the thalamus. *Brain Res.* 563:339-44.
- Cheng MY, Bullock CM, Li C, Lee AG, Bermak JC, Belluzzi J, Weaver DR, Leslie FM, Zhou QY (2002) Prokineticin 2 transmits the behavioural circadian rhythm of the suprachiasmatic nucleus. *Nature* 417:405-10.
- Clark MS, Russo AF (1997) Tissue-specific glucocorticoid regulation of tryptophan hydroxylase mRNA levels. *Brain Res Mol Brain Res.* 48:346-54.
- Clemett DA, Kendall DA, Cockett MI, Marsden CA, Fone KC (1999) Pindolol-insensitive [3H]-5-hydroxytryptamine binding in the rat hypothalamus; identity with 5-hydroxytryptamine₇ receptors. *Br J Pharmacol.* 127:236-42.
- Colwell CS, Ralph MR, Menaker M (1990) Do NMDA receptors mediate the effects of light on circadian behavior? *Brain Res.* 523:117-20.
- Colwell CS, Kaufman CM, Menaker M (1993) Photic induction of Fos in the hamster suprachiasmatic nucleus is inhibited by baclofen but not by diazepam or bicucullin. *Neurosci Lett.* 163:177-81.
- Curzon G, Joseph MH, Knott PJ (1972) Effects of immobilization and food deprivation on rat brain tryptophan metabolism. *J Neurochem.* 19:1967-74.
- Cutrer RA, Ouarour A, Pevet P (1994a) Effects of the 5-HT_{1a} receptor agonist 8-OH-DPAT and other non-photic stimuli on the circadian rhythm of wheel-running activity in hamsters under different constant conditions. *Neurosci Lett.* 172:27-30.
- Cutrer RA, Kalsbeek A, Pevet P (1994b) Specific destruction of the serotonergic afferents to the suprachiasmatic nuclei prevents triazolam-induced phase advances of hamster activity rhythms. *Behav Brain Res.* 62:21-8.
- Cutrer RA, Saboureau M, Pevet P (1996) Phase-shifting effect of 8-OH-DPAT, a 5-HT_{1A}/5-HT₇ receptor agonist, on locomotor activity in golden hamster in constant darkness. *Neurosci Lett.* 210(1):1-4.

D

- Daan S, Pittendrigh CS (1976) A functional analysis of circadian pacemakers in nocturnal rodents. II. The variability of phase response curves. *J Comp Physiol.* 106:253-266.
- Daikoku S, Hisano S, Kagotani Y (1992a) Neuronal associations in the rat suprachiasmatic nucleus demonstrated by immunoelectron microscopy. *J Comp Neurol.* 325:559-71.

Daikoku S, Yokote R, Aizawa T, Kawano H (1992b) Light stimulation of the hypothalamic neuroendocrine system. *Arch Histol Cytol.* 55:67-76.

Dallongeville J, Hecquet B, Lebel P, Edme JL, Le Fur C, Fruchart JC, Auwerx J, Romon M (1998) Short term response of circulating leptin to feeding and fasting in man: influence of circadian cycle. *Int J Obes Relat Metab Disord.* 22:728-33.

Damiola F, Le Minh N, Preitner N, Kornmann B, Fleury-Olela F, Schibler U (2000) Restricted feeding uncouples circadian oscillators in peripheral tissues from the central pacemaker in the suprachiasmatic nucleus. *Genes Dev.* 14:2950-61.

Dardente H, Poirel VJ, Klosen P, Pevet P, Masson-Pevet M (2002) Per and neuropeptide expression in the rat suprachiasmatic nuclei: compartmentalization and differential cellular induction by light. *Brain Res.* 958:261-271.

Dardente H, Menet JS, Challet E, Tournier BB, Pevet P, Masson-Pevet M (2004) Daily and circadian expression of neuropeptides in the suprachiasmatic nuclei of nocturnal and diurnal rodents. *Brain Res Mol Brain Res.* 124:143-51.

Deans C, Leathley M, Goudie A (1989) In vivo interactions of NAN-190, a putative selective 5-HT_{1A} antagonist, with ipsapirone. *Pharmacol Biochem Behav.* 34:927-9.

Descarries L, Watkins KC, Garcia S, Beaudet A (1982) The serotonin neurons in nucleus raphe dorsalis of adult rat: a light and electron microscope radioautographic study. *J Comp Neurol.* 207:239-54.

De Deurwaerdere P, Stinus L, Spampinato U (1998) Opposite change of in vivo dopamine release in the rat nucleus accumbens and striatum that follows electrical stimulation of dorsal raphe nucleus: role of 5-HT₃ receptors. *J Neurosci.* 18:6528-38.

Ding JM, Chen D, Weber ET, Faiman LE, Rea MA, Gillette MU (1994) Resetting the biological clock: mediation of nocturnal circadian shifts by glutamate and NO. *Science* 266:1713-7.

Ding JM, Buchanan GF, Tischkau SA, Chen D, Kuriashkina L, Faiman LE, Alster JM, McPherson PS, Campbell KP, Gillette MU (1998) A neuronal ryanodine receptor mediates light-induced phase delays of the circadian clock. *Nature* 394:381-4.

Dubin AE, Huvar R, D'Andrea MR, Pyati J, Zhu JY, Joy KC, Wilson SJ, Galindo JE, Glass CA, Luo L, Jackson MR, Lovenberg TW, Erlander MG (1999) The pharmacological and functional characteristics of the serotonin 5-HT_{3A} receptor are specifically modified by a 5-HT_{3B} receptor subunit. *J Biol Chem.* 274:30799-810.

Dubois-Dauphin M, Pevet P, Tribollet E, Dreifuss JJ (1990) Vasopressin in the brain of the golden hamster: the distribution of vasopressin binding sites and of immunoreactivity to the vasopressin-related glycopeptide. *J Comp Neurol.* 300:535-48.

Dudley TE, DiNardo LA, Glass JD (1998) Endogenous regulation of serotonin release in the hamster suprachiasmatic nucleus. *J Neurosci.* 18:5045-52.

Duncan MJ, Herron JM, Hill SA (2001) Aging selectively suppresses vasoactive intestinal peptide messenger RNA expression in the suprachiasmatic nucleus of the Syrian hamster. *Mol Brain Res.* 87:196-203.

Duxon MS, Flanigan TP, Reavley AC, Baxter GS, Blackburn TP, Fone KC (1997) Evidence for expression of the 5-hydroxytryptamine-2B receptor protein in the rat central nervous system. *Neuroscience* 76:323-9.

E

Ebling FJ (1996) The role of glutamate in the photic regulation of the suprachiasmatic nucleus. *Prog Neurobiol.* 50:109-32.

Edelstein K, Amir S (1999) The role of the intergeniculate leaflet in entrainment of circadian rhythms to a skeleton photoperiod. *J Neurosci.* 19:372-80.

Edelstein K, de la Iglesia HO, Schwartz WJ, Mrosovsky N (2003) Behavioral arousal blocks light-induced phase advances in locomotor rhythmicity but not light-induced Per1 and Fos expression in the hamster suprachiasmatic nucleus. *Neuroscience* 118:253-61.

Edgar DM, Miller JD, Prosser RA, Dean RR, Dement WC (1993) Serotonin and the mammalian circadian system: II. Phase-shifting rat behavioral rhythms with serotonergic agonists. *J Biol Rhythms* 8:17-31.

Edgar DM, Reid MS, Dement WC (1997) Serotonergic afferents mediate activity-dependent entrainment of the mouse circadian clock. *Am J Physiol.* 273:R265-9.

Eglen (1997) 5-Hydroxytryptamine (5-HT)₄ receptors and central nervous system function: an update. *Prog Drug Res.* 49:9-24.

Ehret M, Gobaille S, Cash CD, Mandel P, Maitre M (1987) Regional distribution in rat brain of tryptophan hydroxylase apoenzyme determined by enzyme-linked immunoassay. *Neurosci Lett.* 73:71-6.

Ehlen JC, Grossman GH, Glass JD (2001) In vivo resetting of the hamster circadian clock by 5-HT₇ receptors in the suprachiasmatic nucleus. *J Neurosci.* 21:5351-7.

Eide EJ, Vielhaber EL, Hinz WA, Virshup DM (2002) The circadian regulatory proteins BMAL1 and cryptochromes are substrates of casein kinase Iepsilon. *J Biol Chem.* 277:17248-54.

Erhardt C, Galani R, Jeltsch H, Cassel JC, Klosen P, Menet JS, Pevet P, Challet E (2004) Modulation of photic resetting in rats by lesions of projections to the suprachiasmatic nuclei expressing p75 neurotrophin receptor. *Eur J Neurosci.* 19:1773-88.

F

Faradji H, Cespuglio R, Jouvét M (1983) Voltammetric measurements of 5-hydroxyindole compounds in the suprachiasmatic nuclei: circadian fluctuations. *Brain Res.* 279:111-9.

Ferguson SA, Kennaway DJ (2000) The ontogeny of induction of c-fos in the rat SCN by a 5-HT(2A/2C) agonist. *Brain Res Dev Brain Res.* 121:229-31.

Feuerstein TJ, Hertzog G (1986) Serotonin (5-HT) enhances hippocampal noradrenaline (NA) release: evidence for facilitatory 5-HT receptors within the CNS. *Naunyn-Schmiedeberg's Arch Pharmacol.* 333:191-7.

Field MD, Maywood ES, O'Brien JA, Weaver DR, Reppert SM, Hastings MH (2000) Analysis of clock proteins in mouse SCN demonstrates phylogenetic divergence of the circadian clockwork and resetting mechanisms. *Neuron* 25:437-47.

Forster EA, Cliffe IA, Bill DJ, Dover GM, Jones D, Reilly Y, Fletcher A (1995) A pharmacological profile of the selective silent 5-HT1A receptor antagonist, WAY-100635. *Eur J Pharmacol.* 281:81-8.

Foster RG, Argamaso S, Coleman S, Colwell CS, Lederman A, Provencio I (1993) Photoreceptors regulating circadian behavior: a mouse model. *J Biol Rhythms* 8 Suppl:S17-23.

Francois-Bellan AM, Bosler O (1992) Convergent serotonin and GABA innervation of VIP neurons in the suprachiasmatic nucleus demonstrated by triple labeling in the rat. *Brain Res.* 595:149-53.

Freedman MS, Lucas RJ, Soni B, von Schantz M, Munoz M, David-Gray Z, Foster R (1999) Regulation of mammalian circadian behavior by non-rod, non-cone, ocular photoreceptors. *Science* 284:502-4.

Fuenmayor LD, Garcia S (1984) The effect of fasting on 5-hydroxytryptamine metabolism in brain regions of the albino rat. *Br J Pharmacol.* 83:357-62.

Fukuhara C, Tosini G (2003) Peripheral circadian oscillators and their rhythmic regulation. *Front Biosci.* 8:d642-51.

Fukuhara C, Shinohara K, Tominaga K, Otori Y, Inouye ST (1993) Endogenous circadian rhythmicity of somatostatin-like-immunoreactivity in the rat suprachiasmatic nucleus. *Brain Res.* 606:28-35.

Fukuhara C, Brewer JM, Dirden JC, Bittman EL, Tosini G, Harrington ME (2001) Neuropeptide Y rapidly reduces Period 1 and Period 2 mRNA levels in the hamster suprachiasmatic nucleus. *Neurosci Lett.* 314:119-22.

Funahashi M, Mitoh Y, Matsuo R (2004) Activation of presynaptic 5-HT3 receptors facilitates glutamatergic synaptic inputs to area postrema neurons in rat brain slices. *Methods Find Exp Clin Pharmacol.* 26:615-22.

G

Gannon RL (2003) Serotonergic serotonin (1A) mixed agonists/antagonists elicit large-magnitude phase shifts in hamster circadian wheel-running rhythms. *Neuroscience* 119:567-76.

Gau D, Lemberger T, von Gall C, Kretz O, Le Minh N, Gass P, Schmid W, Schibler U, Korf HW, Schutz G (2002) Phosphorylation of CREB Ser142 regulates light-induced phase shifts of the circadian clock. *Neuron* 34:245-53.

Gauer F, Schuster C, Poirel VJ, Pévet P, Masson-Pévet M, (1998) Cloning experiments and developmental expression of both melatonin receptor Mel1A mRNA and melatonin binding sites in the Syrian hamster suprachiasmatic nuclei. *Mol Brain Res* 60:193-202.

Gekakis N, Staknis D, Nguyen HB, Davis FC, Wilsbacher LD, King DP, Takahashi JS, Weitz CJ (1998) Role of the CLOCK protein in the mammalian circadian mechanism. *Science* 280:1564-9.

Gershon MD, Liu KP, Karpiak SE, Tamir H (1983) Storage of serotonin in vivo as a complex with serotonin-binding protein in central and peripheral serotonergic neurons. *J Neurosci.* 3:1901-11.

Ginty DD, Kornhauser JM, Thompson MA, Bading H, Mayo KE, Takahashi JS, Greenberg ME (1993) Regulation of CREB phosphorylation in the suprachiasmatic nucleus by light and a circadian clock. *Science* 260:238-41.

Glass JD, Selim M, Rea MA (1994) Modulation of light-induced C-Fos expression in the suprachiasmatic nuclei by 5-HT1A receptor agonists. *Brain Res.* 638:235-42.

Glass JD, Watanabe M, Fedorkova L, Shen H, Ungers G, Rutishauser U (2003) Dynamic regulation of polysialylated neural cell adhesion molecule in the suprachiasmatic nucleus. *Neuroscience* 117:203-11.

Gooley JJ, Lu J, Chou TC, Scammell TE, Saper CB (2001) Melanopsin in cells of origin of the retinohypothalamic tract. *Nat Neurosci.* 4:1165.

Gothert M, Schlicker E, Fink K, Classen K (1987) Effects of RU 24969 on serotonin release in rat brain cortex: further support for the identity of serotonin autoreceptors with 5-HT_{1B} sites. *Arch Int Pharmacodyn Ther.* 288:31-42.

Green DJ, Gillette R (1982) Circadian rhythm of firing rate recorded from single cells in the rat suprachiasmatic brain slice. *Brain Res.* 245:198-200.

Griffin EA Jr, Staknis D, Weitz CJ (1999) Light-independent role of CRY1 and CRY2 in the mammalian circadian clock. *Science* 286:768-71.

Groblewski TA, Nunez AA, Gold RM (1981) Circadian rhythms in vasopressin deficient rats. *Brain Res Bull.* 6:125-30.

Grossman GH, Mistlberger RE, Antle MC, Ehlen JC, Glass JD (2000) Sleep deprivation stimulates serotonin release in the suprachiasmatic nucleus. *Neuroreport.* 11:1929-32.

Grossman GH, Farnbauch L, Glass JD (2004) Regulation of serotonin release in the Syrian hamster intergeniculate leaflet region. *Neuroreport* 15:103-6.

Guan XM, Hess JF, Yu H, Hey PJ, van der Ploeg LH (1997) Differential expression of mRNA for leptin receptor isoforms in the rat brain. *Mol Cell Endocrinol.* 133:1-7.

Guitteny AF, Fouque B, Teoule R, Bloch B (1989) Vasopressin gene expression in the normal and Brattleboro rat: a histological analysis in semi-thin sections with biotinylated oligonucleotide probes. *J Histochem Cytochem.* 37:1479-87.

Güldner FH, Ingham CA (1980) Increase in postsynaptic density material in optic target neurons of the rat suprachiasmatic nucleus after bilateral enucleation. *Neurosci Lett.* 17:27-31.

Güldner FH, Wolff JR (1996) Complex synaptic arrangements in the rat suprachiasmatic nucleus: a possible basis for the "Zeitgeber" and non-synaptic synchronization of neuronal activity. *Cell Tissue Res.* 284:203-214.

Gur E, Newman ME, Avraham Y, Dremencov E, Berry EM (2003) The differential effects of food restriction on 5-HT_{1A} and 5-HT_{1B} receptor mediated control of serotonergic transmission in the hippocampus and hypothalamus of rats. *Nutr Neurosci.* 6:169-75.

H

Hagan JJ, Price GW, Jeffrey P, Deeks NJ, Stean T, Piper D, Smith MI, Upton N, Medhurst AD, Middlemiss DN, Riley GJ, Lovell PJ, Bromidge SM, Thomas DR (2000) Characterization of SB-269970-A, a selective 5-HT(7) receptor antagonist. *Br J Pharmacol.* 130:539-48.

Hakim H, DeBernardo AP, Silver R (1991) Circadian locomotor rhythms, but not photoperiodic responses, survive surgical isolation of the SCN in hamsters. *J Biol Rhythms* 6:97-113.

Halaris AE, DeMet EM (1978) Active uptake of [3H]5-HT by synaptic vesicles from rat brain. *J Neurochem.* 31:591-7.

Hall AC, Hoffmaster RM, Stern EL, Harrington ME, Bickar D (1997) Suprachiasmatic nucleus neurons are glucose sensitive. *J Biol Rhythms* 12:388-400.

Halliday G, Harding A, Paxinos C (1995) Serotonin and tachykinin system. In: *The rat nervous system*, Paxinos G. (ed.), Academic Press, 929-974.

Hamada T, Shibata S, Tsuneyoshi A, Tominaga K, Watanabe S (1993) Effect of somatostatin on circadian rhythms of firing and 2-deoxyglucose uptake in rat suprachiasmatic slices. *Am J Physiol.* 265:R199-204.

Hamaguchi H, Fujimoto K, Kawamoto T, Noshiro M, Maemura K, Takeda N, Nagai R, Furukawa M, Honma S, Honma K, Kurihara H, Kato Y (2004) Expression of the gene for Dec2, a basic helix-loop-helix transcription factor, is regulated by a molecular clock system. *Biochem J.* 382:43-50.

Hannibal J, Ding JM, Chen D, Fahrenkrug J, Larsen PJ, Gillette MU, Mikkelsen JD (1997) Pituitary adenylate cyclase-activating peptide (PACAP) in the retinohypothalamic tract: a potential daytime regulator of the biological clock. *J Neurosci.* 17:2637-44.

Hannibal J, Ding JM, Chen D, Fahrenkrug J, Larsen PJ, Gillette MU, Mikkelsen JD (1998) Pituitary adenylate cyclase activating peptide (PACAP) in the retinohypothalamic tract: a daytime regulator of the biological clock. *Ann N Y Acad Sci.* 865:197-206.

Hannibal J, Moller M, Ottersen OP, Fahrenkrug J (2000) PACAP and glutamate are co-stored in the retinohypothalamic tract. *J Comp Neurol.* 418:147-55.

Hara R, Wan K, Wakamatsu H, Aida R, Moriya T, Akiyama M, Shibata S (2001) Restricted feeding entrains liver clock without participation of the suprachiasmatic nucleus. *Genes Cells* 6:269-78.

Harmar AJ, Marston HM, Shen S, Spratt C, West KM, Sheward WJ, Morrison CF, Dorin JR, Piggins HD, Reubi JC, Kelly JS, Maywood ES, Hastings MH (2002) The VPAC(2) receptor is essential for circadian function in the mouse suprachiasmatic nuclei. *Cell* 109:497-508.

- Harrington ME, Hoque S (1997) NPY opposes PACAP phase shifts via receptors different from those involved in NPY phase shifts. *Neuroreport* 8:2677-80.
- Harrington ME, Rusak B (1991) Luminance coding properties of intergeniculate leaflet neurons in the golden hamster and the effects of chronic clorgyline. *Brain Res.* 554:95-104.
- Harrington ME, Hoque S, Hall A, Golombek D, Biello S (1999) Pituitary adenylate cyclase activating peptide phase shifts circadian rhythms in a manner similar to light. *J Neurosci.* 19:6637-42.
- Hastings MH, Field MD, Maywood ES, Weaver DR, Reppert SM (1999) Differential regulation of mPER1 and mTIM proteins in the mouse suprachiasmatic nuclei: new insights into a core clock mechanism. *J Neurosci.* 19:RC11.
- Hattar S, Liao HW, Takao M, Berson DM, Yau KW (2002) Melanopsin-containing retinal ganglion cells: architecture, projections, and intrinsic photosensitivity. *Science* 295:1065-70.
- Hattar S, Lucas RJ, Mrosovsky N, Thompson S, Douglas RH, Hankins MW, Lem J, Biel M, Hofmann F, Foster RG, Yau KW (2003) Melanopsin and rod-cone photoreceptive systems account for all major accessory visual functions in mice. *Nature* 424:76-81.
- Hay-Schmidt A, Vrang N, Larsen PJ, Mikkelsen JD (2003) Projections from the raphe nuclei to the suprachiasmatic nucleus of the rat. *J Chem Neuroanat.* 25:293-310.
- Heidmann DE, Metcalf MA, Kohlen R, Hamblin MW (1997) Four 5-hydroxytryptamine₇ (5-HT₇) receptor isoforms in human and rat produced by alternative splicing: species differences due to altered intron-exon organization. *J Neurochem.* 68:1372-81.
- Hermes ML, Coderre EM, Buijs RM, Renaud LP (1996) GABA and glutamate mediate rapid neurotransmission from suprachiasmatic nucleus to hypothalamic paraventricular nucleus in rat. *J Physiol.* 496:749-57.
- Hery F, Faudon M, Fueri C (1986) Release of serotonin in structures containing serotonergic nerve cell bodies: dorsalis raphe nucleus and nodose ganglia of the cat. *Ann N Y Acad Sci.* 473:239-55.
- Herzog ED, Takahashi JS, Block GD (1998) Clock controls circadian period in isolated suprachiasmatic nucleus neurons. *Nat Neurosci.* 1:708-13.
- Hillegaart V, Hjorth S, Ahlenius S (1990) Effects of 5-HT and 8-OH-DPAT on forebrain monoamine synthesis after local application into the median and dorsal raphe nuclei of the rat. *J Neural Transm Gen Sect.* 81:131-45.
- Hisano S, Chikamori-Aoyama M, Katoh S, Kagotani Y, Daikoku S, Chihara K (1988) Suprachiasmatic nucleus neurons immunoreactive for vasoactive intestinal polypeptide have synaptic contacts with axons immunoreactive for neuropeptide Y: an immunoelectron microscopic study in the rat. *Neurosci Lett.* 88:145-50.
- Hjorth S, Sharp T (1991) Effect of the 5-HT_{1A} receptor agonist 8-OH-DPAT on the release of 5-HT in dorsal and median raphe-innervated rat brain regions as measured by in vivo microdialysis. *Life Sci.* 48:1779-86.
- Hogenesch JB, Gu YZ, Jain S, Bradfield CA (1998) The basic-helix-loop-helix-PAS orphan MOP3 forms transcriptionally active complexes with circadian and hypoxia factors. *Proc Natl Acad Sci U S A* 95:5474-9.
- Holmes MM, Mistlberger RE (2000) Food anticipatory activity and photic entrainment in food-restricted BALB/c mice. *Physiol Behav.* 68:655-666.
- Honma S, Ikeda M, Abe H, Tanahashi Y, Namihira M, Honma K, Nomura M (1998a) Circadian oscillation of BMAL1, a partner of a mammalian clock gene Clock, in rat suprachiasmatic nucleus. *Biochem Biophys Res Commun* 250:83-7.
- Honma S, Shirakawa T, Katsuno Y, Namihira M, Honma K (1998b) Circadian periods of single suprachiasmatic neurons in rats. *Neurosci Lett.* 250:157-60.
- Honma S, Shirakawa T, Nakamura W, Honma K (2000) Synaptic communication of cellular oscillations in the rat suprachiasmatic neurons. *Neurosci Lett.* 294:113-6.
- Honma S, Kawamoto T, Takagi Y, Fujimoto K, Sato F, Noshiro M, Kato Y, Honma K (2002) Dec1 and Dec2 are regulators of the mammalian molecular clock. *Nature* 419:841-4.
- Honrado GI, Johnson RS, Golombek DA, Spiegelman BM, Papaioannou VE, Ralph MR (1996) The circadian system of c-fos deficient mice. *J Comp Physiol* 178:563-70.
- Horikawa K, Yokota S, Fuji K, Akiyama M, Moriya T, Okamura H, Shibata S (2000) Nonphotic entrainment by 5-HT_{1A/7} receptor agonists accompanied by reduced Per1 and Per2 mRNA levels in the suprachiasmatic nuclei. *J Neurosci.* 20:5867-73.
- Horikawa K, Shibata S (2004) Phase-resetting response to (+)8-OH-DPAT, a serotonin 1A/7 receptor agonist, in the mouse in vivo. *Neurosci Lett.* 368:130-4.
- Hou M, Kanje M, Longmore J, Tajti J, Uddman R, Edvinsson L (2001) 5-HT(1B) and 5-HT(1D) receptors in the human trigeminal ganglion: co-localization with calcitonin gene-related peptide, substance P and nitric oxide synthase. *Brain Res.* 909:112-20.

Hoyer D, Clarke DE, Fozard JR, Hartig PR, Martin GR, Mylecharane EJ, Saxena PR, Humphrey PP (1994) International Union of Pharmacology classification of receptors for 5-hydroxytryptamine (Serotonin). *Pharmacol Rev.* 46:157-203.

Hoyer D, Hannon JP, Martin GR (2002) Molecular, pharmacological and functional diversity of 5-HT receptors. *Pharmacol Biochem Behav.* 71:533-54.

Huang SK, Pan JT (1993) Potentiating effects of serotonin and vasoactive intestinal peptide on the action of glutamate on suprachiasmatic neurons in brain slices. *Neurosci Lett.* 159:1-4.

Huether G, Zhou D, Schmidt S, Wiltfang J, Ruther E (1997) Long-term food restriction down-regulates the density of serotonin transporters in the rat frontal cortex. *Biol Psychiatry.* 41:1174-80.

Huhman KL, Albers HE (1994) Neuropeptide Y microinjected into the suprachiasmatic region phase shifts circadian rhythms in constant darkness. *Peptides* 15:1475-8.

Huhman KL, Jasnow AM, Sisitsky AK, Albers HE (1999) Glutamic acid decarboxylase mRNA in the suprachiasmatic nucleus of rats housed in constant darkness. *Brain Res.* 851:266-9.

Hussein L, Goedde HW (1979) Diurnal rhythm in the plasma level of total and free tryptophan and cortisol in rabbits. Effect of haloperidol and chlorpromazine. *Res Exp Med (Berl)* 176:123-30.

I

Ibata Y, Takahashi Y, Okamura H, Kawakami F, Terubayashi H, Kubo T, Yanaihara N (1989) Vasoactive intestinal peptide (VIP)-like immunoreactive neurons located in the rat suprachiasmatic nucleus receive a direct retinal projection. *Neurosci Lett.* 97:1-5.

Ibata Y, Tanaka M, Ichitani Y, Takahashi Y, Okamura H (1993) Neuronal interaction between VIP and vasopressin neurons in the rat suprachiasmatic nucleus. *Neuroreport* 4:128-30.

Ibata Y, Okamura H, Tanaka M, Tamada Y, Hayashi S, Iijima N, Matsuda T, Munekawa K, Takamatsu T, Hisa Y, Shigeyoshi Y, Amaya F (1999) Functional morphology of the suprachiasmatic nucleus. *Front Neuroendocrinol.* 20:241-268.

Ikeda M, Nomura M (1997) cDNA cloning and tissue-specific expression of a novel basic helix-loop-helix/PAS protein (BMAL1) and identification of alternatively spliced variants with alternative translation initiation site usage. *Biochem Biophys Res Commun* 233:258-64.

Ingram CD, Snowball RK, Mihai R (1996) Circadian rhythm of neuronal activity in suprachiasmatic nucleus slices from the vasopressin-deficient Brattleboro rat. *Neuroscience* 75:635-41.

Inouye ST (1996) Circadian rhythms of neuropeptides in the suprachiasmatic nucleus. *Prog Brain Res.* 111:75-90.

Inouye ST, Kawamura H (1979) Persistence of circadian rhythmicity in a mammalian hypothalamic "island" containing the suprachiasmatic nucleus. *Proc Natl Acad Sci U S A* 76:5962-5966.

Isobe Y, Nishihara K (2002) Serotonin-stimulated glutamate release from an SCN explant culture was higher during light period. *Brain Res Bull.* 58:401-4.

J

Jacobs BL, Azmitia EC (1992) Structure and function of the brain serotonin system. *Physiol Rev.* 72:165-229.

Janik D, Mrosovsky N (1994) Intergeniculate leaflet lesions and behaviorally-induced shifts of circadian rhythms. *Brain Res.* 651:174-82.

Janik D, Godfrey M, Mrosovsky N (1994) Phase angle changes of photically entrained circadian rhythms following a single nonphotic stimulus. *Physiol Behav.* 55:103-7.

Jasper JR, Kosaka A, To ZP, Chang DJ, Eglen RM (1997) Cloning, expression and pharmacology of a truncated splice variant of the human 5-HT7 receptor (h5-HT7b). *Br J Pharmacol.* 122:126-32.

Jin X, Shearman LP, Weaver DR, Zylka MJ, de Vries GJ, Reppert SM (1999) A molecular mechanism regulating rhythmic output from the suprachiasmatic circadian clock. *Cell* 96:57-68.

Jobst EE, Allen CN (2002) Calbindin neurons in the hamster suprachiasmatic nucleus do not exhibit a circadian variation in spontaneous firing rate. *Eur J Neurosci.* 16:2469-74.

Johnson RF, Moore RY, Morin LP (1988a) Loss of entrainment and anatomical plasticity after lesions of the hamster retinohypothalamic tract. *Brain Res.* 460:297-313.

Johnson RF, Morin LP, Moore RY (1988b) Retinohypothalamic projections in the hamster and rat demonstrated using cholera toxin. *Brain Res.* 462:301-12.

Joy JE, Turek FW (1992) Combined effects on the circadian clock of agents with different phase response curves: phase-shifting effects of triazolam and light. *J Biol Rhythms* 7:51-63.

K

Kalen P, Karlson M, Wiklund L (1985) Possible excitatory amino acid afferents to nucleus raphe dorsalis of the rat investigated with retrograde wheat germ agglutinin and D-[3H]aspartate tracing. *Brain Res.* 360:285-97.

- Kalen P, Rosegren E, Lindvall O, Bjorklund A (1989) Hippocampal Noradrenaline and Serotonin Release over 24 Hours as Measured by the Dialysis Technique in Freely Moving Rats: Correlation to Behavioural Activity State, Effect of Handling and Tail-Pinch. *Eur J Neurosci*. 1:181-188.
- Kalkowski A, Wollnik F (1999) Local effects of the serotonin agonist quipazine on the suprachiasmatic nucleus of rats. *Neuroreport* 10:3241-6.
- Kalkowski A (2000) Serotonin und seine lichtähnliche Wirkung im circadianen System der Ratte. PhD thesis, University of Stuttgart.
- Kalsbeek A, Buijs RM, van Heerikhuizen JJ, Arts M, van der Woude TP (1992) Vasopressin-containing neurons of the suprachiasmatic nuclei inhibit corticosterone release. *Brain Res*. 580:62-7.
- Kalsbeek A, Rijkers M, Vivien-Roels B, Pevet P (1993) Vasopressin and vasoactive intestinal peptide infused in the paraventricular nucleus of the hypothalamus elevate plasma melatonin levels. *J Pineal Res*. 15:46-52.
- Kalsbeek A, van Heerikhuizen JJ, Wortel J, Buijs RM (1998) Restricted daytime feeding modifies suprachiasmatic nucleus vasopressin release in rats. *J Biol Rhythms* 13:18-29.
- Kalsbeek A, Cutrera RA, Van Heerikhuizen JJ, Van Der Vliet J, Buijs RM (1999) GABA release from suprachiasmatic nucleus terminals is necessary for the light-induced inhibition of nocturnal melatonin release in the rat. *Neuroscience* 91:453-61.
- Kalsbeek A, Fliers E, Romijn JA, La Fleur SE, Wortel J, Bakker O, Endert E, Buijs RM (2001) The suprachiasmatic nucleus generates the diurnal changes in plasma leptin levels. *Endocrinology* 142:2677-85.
- Kan JP, Chouvet G, Hery F, Debilly G, Mermet A, Glowinski J, Pujol JF (1977) Daily variations of various parameters of serotonin metabolism in the rat brain. I. Circadian variations of tryptophan-5-hydroxylase in the raphe nuclei and the striatum. *Brain Res*. 123:125-36.
- Kantak KM, Wayner MJ, Stein JM (1978) Effects of various periods of food deprivation on serotonin synthesis in the lateral hypothalamus. *Pharmacol Biochem Behav*. 9:535-41.
- Kawamata T, Omote K, Toriyabe M, Yamamoto H, Namiki A (2003) The activation of 5-HT(3) receptors evokes GABA release in the spinal cord. *Brain Res*. 978:250-5.
- Kawamoto T, Noshiro M, Sato F, Maemura K, Takeda N, Nagai R, Iwata T, Fujimoto K, Furukawa M, Miyazaki K, Honma S, Honma K, Kato Y (2004) A novel autofeedback loop of Dec1 transcription involved in circadian rhythm regulation. *Biochem Biophys Res Commun* 313:117-24.
- Kawano H, Decker K, Reuss S (1996) Is there a direct retina-raphé-suprachiasmatic nucleus pathway in the rat? *Neurosci Lett*. 212:143-6.
- Kennaway DJ (1997) Light, neurotransmitters and the suprachiasmatic nucleus control of pineal melatonin production in the rat. *Biol Signals* 6:247-54.
- Kennaway DJ, Moyer RW (1998) Serotonin 5-HT_{2c} agonists mimic the effect of light pulses on circadian rhythms. *Brain Res*. 806:257-70.
- Kennaway DJ, Moyer RW (1999) MK-801 administration blocks the effects of a 5-HT(2A/2C) agonist on melatonin rhythmicity and c-fos induction in the suprachiasmatic nucleus. *Brain Res*. 845:102-6.
- Kennaway DJ, Rowe SA, Ferguson SA (1996) Serotonin agonists mimic the phase shifting effects of light on the melatonin rhythm in rats. *Brain Res*. 737:301-7.
- Kennaway DJ, Moyer RW, Voultzios A, Varcoe TJ (2001) Serotonin, excitatory amino acids and the photic control of melatonin rhythms and SCN c-FOS in the rat. *Brain Res*. 897:36-43.
- Kennett GA, Wood MD, Glen A, Grewal S, Forbes I, Gadre A, Blackburn TP (1994) In vivo properties of SB 200646A, a 5-HT_{2C/2B} receptor antagonist. *Br J Pharmacol*. 111:797-802.
- Kennett GA, Ainsworth K, Trail B, Blackburn TP (1997) BW 723C86, a 5-HT_{2B} receptor agonist, causes hyperphagia and reduced grooming in rats. *Neuropharmacology* 36:233-9.
- Kikuchi C, Nagaso H, Hiranuma T, Koyama M (1999) Tetrahydrobenzindoles: selective antagonists of the 5-HT₇ receptor. *J Med Chem*. 42:533-5.
- Kim DY, Kang HC, Shin HC, Lee KJ, Yoon YW, Han HC, Na HS, Hong SK, Kim YI (2001) Substance p plays a critical role in photic resetting of the circadian pacemaker in the rat hypothalamus. *J Neurosci*. 21:4026-31.
- King DP, Zhao Y, Sangoram AM, Wilsbacher LD, Tanaka M, Antoch MP, Steeves TD, Vitaterna MH, Kornhauser JM, Lowrey PL, Turek FW, Takahashi JS (1997) Positional cloning of the mouse circadian clock gene. *Cell* 89:641-53.
- Kim JK, Summer SN, Wood WM, Brown JL, Schrier RW (1997) Arginine vasopressin secretion with mutants of wild-type and Brattleboro rats AVP gene. *J Am Soc Nephrol*. 8:1863-9.
- Kiss J, Halasz B (1996) Synaptic contacts between cholinergic afferents and suprachiasmatic neurones of the rat. *Neuroreport* 7:1961-4.
- Klein D, Moore RY, Reppert SM (Eds) (1991) *Suprachiasmatic Nucleus: The Mind's Clock*, Oxford University Press, Oxford.

Kogan HA, Marsden CA, Fone KC (2002) DR4004, a putative 5-HT(7) receptor antagonist, also has functional activity at the dopamine D2 receptor. *Eur J Pharmacol.* 449:105-11.

Kohler M, Kalkowski A, Wollnik F (1999) Serotonin agonist quipazine induces photic-like phase shifts of the circadian activity rhythm and c-Fos expression in the rat suprachiasmatic nucleus. *J Biol Rhythms* 14:131-40.

Kohler M, Kalkowski A, Wollnik F (2000) Species differences between hamsters and rats with regard to the putative role of serotonin in the circadian system. *Biol Rhythm Res.* 31:340-354.

Kohsaka S, Takamatsu K, Tsukada Y (1980) Effect of food restriction on serotonin metabolism in rat brain. *Neurochem Res.* 5:69-79.

Kopp MD, Schomerus C, Dehghani F, Korf HW, Meissl H (1999) Pituitary adenylate cyclase-activating polypeptide and melatonin in the suprachiasmatic nucleus: effects on the calcium signal transduction cascade. *J Neurosci.* 19:206-19.

Kornhauser JM, Nelson DE, Mayo KE, Takahashi JS (1990) Photic and circadian regulation of c-fos gene expression in the hamster suprachiasmatic nucleus. *Neuron* 5:127-34.

Kramer A, Yang FC, Snodgrass P, Li X, Scammell TE, Davis FC, Weitz CJ (2001) Regulation of daily locomotor activity and sleep by hypothalamic EGF receptor signaling. *Science* 294:2511-5.

Kume K, Zylka MJ, Sriram S, Shearman LP, Weaver DR, Jin X, Maywood ES, Hastings MH, Reppert SM (1999) mCRY1 and mCRY2 are essential components of the negative limb of the circadian clock feedback loop. *Cell* 98:193-205.

L

Laporte AM, Koscielniak T, Ponchant M, Verge D, Hamon M, Gozlan H (1992) Quantitative autoradiographic mapping of 5-HT₃ receptors in the rat CNS using [¹²⁵I]iodo-zacopride and [³H]zacopride as radioligands. *Synapse* 10:271-81.

Lavialle M, Serviere J (1993) Circadian fluctuations in GFAP distribution in the Syrian hamster suprachiasmatic nucleus. *Neuroreport* 4:1243-6.

Leak RK, Card JP, Moore RY (1999) Suprachiasmatic pacemaker organization analyzed by viral transsynaptic transport. *Brain Res.* 819:23-32.

Leathwood PD (1987) Tryptophan availability and serotonin synthesis. *Proc Nutr Soc.* 46:143-56.

Lee C, Etchegaray JP, Cagampang FR, Loudon AS, Reppert SM (2001) Posttranslational mechanisms regulate the mammalian circadian clock. *Cell* 107:855-67.

Lehman MN, Silver R, Gladstone WR, Kahn RM, Gibson M, Bittman EL (1987) Circadian rhythmicity restored by neural transplant. Immunocytochemical characterization of the graft and its integration with the host brain. *J Neurosci.* 7:1626-38.

LeSauter J, Silver R (1998) Output signals of the SCN. *Chronobiol Int.* 15:535-50.

LeSauter J, Silver R (1999) Localization of a suprachiasmatic nucleus subregion regulating locomotor rhythmicity. *J Neurosci.* 19:5574-85.

LeSauter J, Kriegsfeld LJ, Hon J, Silver R (2002) Calbindin-D(28K) cells selectively contact intra-SCN neurons. *Neuroscience* 111:575-85.

Lincoln GA, Messenger S, Andersson A, Hazlerigg D (2002) Temporal expression of seven clock genes in the suprachiasmatic nucleus and the pars tuberalis of the sheep: evidence for an internal coincidence timer. *Proc Natl Acad Sci USA* 99:13890-13895.

Liou SY, Albers HE (1990) Single unit response of neurons within the hamster suprachiasmatic nucleus to GABA and low chloride perfusate during the day and night. *Brain Res Bull.* 25:93-8.

Liou SY, Shibata S, Ueki S (1986) Effect of monoamines on field potentials in the suprachiasmatic nucleus of slices of hypothalamus of the rat evoked by stimulation of the optic nerve. *Neuropharmacology* 25:1009-14.

Liu C, Reppert SM (2000) GABA synchronizes clock cells within the suprachiasmatic circadian clock. *Neuron* 25:123-8.

Liu C, Weaver DR, Strogatz SH, Reppert SM (1997) Cellular construction of a circadian clock: period determination in the suprachiasmatic nuclei. *Cell* 91:855-60.

Loizou G, Redfern PH (1988) Circadian variation in the uptake of tryptophan by cortical synaptosomes of the rat brain. *Chronobiol Int.* 5:331-6.

Loric S, Launay JM, Colas JF, Maroteaux L (1992) New mouse 5-HT₂-like receptor. Expression in brain, heart and intestine. *FEBS Lett.* 312:203-7.

Lowrey PL, Shimomura K, Antoch MP, Yamazaki S, Zemenides PD, Ralph MR, Menaker M, Takahashi JS (2000) Positional syntenic cloning and functional characterization of the mammalian circadian mutation tau. *Science* 288:483-92.

Low-Zeddies SS, Takahashi JS (2001) Chimera analysis of the Clock mutation in mice shows that complex cellular integration determines circadian behavior. *Cell* 105:25-42.

M

- Mahoney MM, Nunez AA, Smale L (2000) Calbindin and Fos within the suprachiasmatic nucleus and the adjacent hypothalamus of *Arvicantis niloticus* and *Rattus norvegicus*. *Neuroscience* 99:565-75.
- Malek ZS, Pevet P, Raison S (2004) Circadian change in tryptophan hydroxylase protein levels within the rat intergeniculate leaflets and raphe nuclei. *Neuroscience* 125:749-58.
- Manrique C, Francois-Bellan AM, Segu L, Becquet D, Hery M, Faudon M, Hery F (1994) Impairment of serotonergic transmission is followed by adaptive changes in 5HT1B binding sites in the rat suprachiasmatic nucleus. *Brain Res.* 663:93-100.
- Manrique C, Hery F, Faudon M, Francois-Bellan AM (1999) Indirect evidence for an association of 5-HT(1B) binding sites with retinal and geniculate axon terminals in the rat suprachiasmatic nucleus. *Synapse* 33:314-23.
- Marchant EG, Mistlberger RE (1995) Morphine phase-shifts circadian rhythms in mice: role of behavioural activation. *Neuroreport* 7:209-12.
- Marchant EG, Mistlberger RE (1996) Entrainment and phase shifting of circadian rhythms in mice by forced treadmill running. *Physiol Behav.* 60:657-63.
- Marchant EG, Morin LP (1999) The hamster circadian rhythm system includes nuclei of the subcortical visual shell. *J Neurosci.* 19:10482-93.
- Marchant EG, Watson NV, Mistlberger RE (1997) Both neuropeptide Y and serotonin are necessary for entrainment of circadian rhythms in mice by daily treadmill running schedules. *J Neurosci.* 17:7974-87.
- Martinez-Merlos MT, Angeles-Castellanos M, Diaz-Munoz M, Aguilar-Roblero R, Mendoza J, Escobar C (2004) Dissociation between adipose tissue signals, behavior and the food-entrained oscillator. *J Endocrinol.* 181:53-63.
- Mathur A, Golombek DA, Ralph MR (1996) cGMP-dependent protein kinase inhibitors block light-induced phase advances of circadian rhythms in vivo. *Am J Physiol.* 270:R1031-6.
- Maurel D, Sage D, Mekaouche M, Bosler O (2000) Glucocorticoids up-regulate the expression of glial fibrillary acidic protein in the rat suprachiasmatic nucleus. *Glia* 29:212-21.
- Maywood ES, Mrosovsky N (2001) A molecular explanation of interactions between photic and non-photoc circadian clock-resetting stimuli. *Brain Res Gene Expr Patterns* 1:27-31.
- Maywood ES, Smith E, Hall SJ, Hastings MH (1997) A thalamic contribution to arousal-induced, non-photoc entrainment of the circadian clock of the Syrian hamster. *Eur J Neurosci.* 9:1739-47.
- Maywood ES, Mrosovsky N, Field MD, Hastings MH (1999) Rapid down-regulation of mammalian period genes during behavioral resetting of the circadian clock. *Proc Natl Acad Sci U S A* 96:15211-6.
- Maywood ES, Okamura H, Hastings MH (2002) Opposing actions of neuropeptide Y and light on the expression of circadian clock genes in the mouse suprachiasmatic nuclei. *Eur J Neurosci.* 15:216-20.
- Maywood ES, O'Brien JA, Hastings MH (2003) Expression of mCLOCK and other circadian clock-relevant proteins in the mouse suprachiasmatic nuclei. *J Neuroendocrinol.* 15:329-34.
- Mazzia C, Hicks GA, Clerc N (2003) Neuronal location of 5-hydroxytryptamine₃ receptor-like immunoreactivity in the rat colon. *Neuroscience* 116:1033-41.
- McKenney JD, Glennon RA (1986) TFMPP may produce its stimulus effects via a 5-HT_{1B} mechanism. *Pharmacol Biochem Behav.* 24:43-7.
- McLennan IS, Lees GJ (1978) Diurnal changes in the kinetic properties of tryptophan hydroxylase from rat brain. *J Neurochem.* 31:557-9.
- Medanic M, Gillette MU (1992) Serotonin regulates the phase of the rat suprachiasmatic circadian pacemaker in vitro only during the subjective day. *J Physiol.* 450:629-42.
- Meerlo P, van den Hoofdakker RH, Koolhaas JM, Daan S (1997) Stress-induced changes in circadian rhythms of body temperature and activity in rats are not caused by pacemaker changes. *J Biol Rhythms* 12:80-92.
- Meerlo P, Sgoifo A, Turek FW (2002) The effects of social defeat and other stressors on the expression of circadian rhythms. *Stress* 5:15-22.
- Meijer JH, Albus H, Weidema F, Ravesloot JH (1993) The effects of glutamate on membrane potential and discharge rate of suprachiasmatic neurons. *Brain Res.* 603:284-8.
- Menet JS, Vuillez P, Pevet P (2003) Calbindin expression in the hamster suprachiasmatic nucleus depends on day-length. *Neuroscience* 122:591-8.
- Messenger S, Ross AW, Barrett P, Morgan PJ (1999) Decoding photoperiodic time through Per1 and ICER gene amplitude. *Proc Natl Acad Sci U S A* 96:9938-43.
- Meyer-Bernstein EL, Morin LP (1996) Differential serotonergic innervation of the suprachiasmatic nucleus and the intergeniculate leaflet and its role in circadian rhythm modulation. *J Neurosci.* 16:2097-111.

- Meyer-Bernstein EL, Morin LP (1998) Destruction of serotonergic neurons in the median raphe nucleus blocks circadian rhythm phase shifts to triazolam but not to novel wheel access. *J Biol Rhythms* 13:494-505.
- Meyer-Bernstein EL, Morin LP (1999) Electrical stimulation of the median or dorsal raphe nuclei reduces light-induced FOS protein in the suprachiasmatic nucleus and causes circadian activity rhythm phase shifts. *Neuroscience* 92:267-79.
- Meyer-Bernstein EL, Blanchard JH, Morin LP (1997) The serotonergic projection from the median raphe nucleus to the suprachiasmatic nucleus modulates activity phase onset, but not other circadian rhythm parameters. *Brain Res.* 755:112-20.
- Meyer-Bernstein EL, Jetton AE, Matsumoto SI, Markuns JF, Lehman MN, Bittman EL (1999) Effects of suprachiasmatic transplants on circadian rhythms of neuroendocrine function in golden hamsters. *Endocrinology* 140:207-18.
- Mihai R, Coculescu M, Wakerley JB, Ingram CD (1994a) The effects of [Arg8]vasopressin and [Arg8]vasotocin on the firing rate of suprachiasmatic neurons in vitro. *Neuroscience* 62:783-92.
- Mihai R, Juss TS, Ingram CD (1994b) Suppression of suprachiasmatic nucleus neurone activity with a vasopressin receptor antagonist: possible role for endogenous vasopressin in circadian activity cycles in vitro. *Neurosci Lett.* 179:95-9.
- Mikkelsen JD (1992) The organization of the crossed geniculogeniculate pathway of the rat: a Phaseolus vulgaris-leucoagglutinin study. *Neuroscience* 48:953-62.
- Mikkelsen JD, Vrang N (1994) A direct pretectosuprachiasmatic projection in the rat. *Neuroscience* 62:497-505.
- Mikkelsen JD, Larsen PJ, O'Hare MM, Wiegand SJ (1991) Gastrin releasing peptide in the rat suprachiasmatic nucleus: an immunohistochemical, chromatographic and radioimmunological study. *Neuroscience* 40:55-66.
- Miquel MC, Emerit MB, Gingrich JA, Nosjean A, Hamon M, el Mestikawy S (1995) Developmental changes in the differential expression of two serotonin 5-HT₃ receptor splice variants in the rat. *J Neurochem.* 65:475-83.
- Mistlberger RE (1991) Scheduled daily exercise or feeding alters the phase of photic entrainment in Syrian hamsters. *Physiol Behav.* 50:1257-60.
- Mistlberger RE (1994) Circadian food-anticipatory activity: formal models and physiological mechanisms. *Neurosci Biobehav Rev.* 18:171-95.
- Mistlberger RE, Antle MC (1998) Behavioral inhibition of light-induced circadian phase resetting is phase and serotonin dependent. *Brain Res.* 786:31-8.
- Mistlberger RE, Holmes MM (1999) Morphine-induced activity attenuates phase shifts to light in C57BL/6J mice. *Brain Res.* 829:113-9.
- Mistlberger RE, Holmes MM (2000) Behavioral feedback regulation of circadian rhythm phase angle in light-dark entrained mice. *Am J Physiol.* 279:R813-R821.
- Mistlberger RE, Landry GJ, Marchant EG (1997) Sleep deprivation can attenuate light-induced phase shifts of circadian rhythms in hamsters. *Neurosci Lett.* 238:5-8.
- Miyamoto Y, Sancar A (1999) Circadian regulation of cryptochrome genes in the mouse. *Brain Res Mol Brain Res.* 71:238-43.
- Moga MM, Moore RY (1996) Putative excitatory amino acid projections to the suprachiasmatic nucleus in the rat. *Brain Res.* 743:171-7.
- Moga MM, Moore RY (1997) Organization of neural inputs to the suprachiasmatic nucleus in the rat. *J Comp Neurol.* 389:508-34.
- Moore RY (1983) Organization and function of a central nervous system circadian oscillator: the suprachiasmatic hypothalamic nucleus. *Fed Proc.* 42:2783-9.
- Moore RY, Card JP (1994) Intergeniculate leaflet: an anatomically and functionally distinct subdivision of the lateral geniculate complex. *J Comp Neurol.* 344:403-30.
- Moore RY, Eichler VB (1972) Loss of a circadian adrenal corticosterone rhythm following suprachiasmatic lesions in the rat. *Brain Res.* 42:201-206.
- Moore RY, Leak RK (2001) Suprachiasmatic nucleus. Takahashi JS, Turek FW and Moore RY, eds (New-York: Kluwer Academic/Plenum Publishers), pp. 141-179.
- Moore RY, Lenn NJ (1972) A retinohypothalamic projection in the rat. *J Comp Neurol.* 146:1-14.
- Moore RY, Speh JC (1993) GABA is the principal neurotransmitter of the circadian system. *Neurosci Lett.* 150:112-6.
- Moore RY, Speh JC, Card JP (1995) The retinohypothalamic tract originates from a distinct subset of retinal ganglion cells. *J Comp Neurol.* 352:351-66.
- Moore RY, Speh JC, Leak RK (2002) Suprachiasmatic nucleus organization. *Cell Tissue Res.* 309:89-98.
- Morales M, Wang SD (2002) Differential composition of 5-hydroxytryptamine₃ receptors synthesized in the rat CNS and peripheral nervous system. *J Neurosci.* 22:6732-41.
- Morin LP (1994) The circadian visual system. *Brain Res Brain Res Rev.* 19(1):102-27.

Morin LP (1999) Serotonin and the regulation of mammalian circadian rhythmicity. *Ann Med.* 31:12-33.

Morin LP, Blanchard JH (1998) Interconnections among nuclei of the subcortical visual shell: the intergeniculate leaflet is a major constituent of the hamster subcortical visual system. *J Comp Neurol.* 396:288-309.

Morin LP, Blanchard JH (1999) Forebrain connections of the hamster intergeniculate leaflet: comparison with those of ventral lateral geniculate nucleus and retina. *Vis Neurosci.* 16:1037-54.

Moriya T, Horikawa K, Akiyama M, Shibata S (2000) Correlative association between N-methyl-D-aspartate receptor-mediated expression of period genes in the suprachiasmatic nucleus and phase shifts in behavior with photic entrainment of clock in hamsters. *Mol Pharmacol.* 58:1554-62.

Mosko SS, Jacobs BL (1977) Electrophysiological evidence against negative neuronal feedback from the forebrain controlling midbrain raphe unit activity. *Brain Res.* 119:291-303.

Mosko SS, Haubrich D, Jacobs BL (1977) Serotonergic afferents to the dorsal raphe nucleus: evidence from HRP and synaptosomal uptake studies. *Brain Res.* 119:269-90.

Moyer RW, Kennaway DJ (1999) Immunohistochemical localization of serotonin receptors in the rat suprachiasmatic nucleus. *Neurosci Lett.* 271:147-50.

Moyer RW, Kennaway DJ (2000) Serotonin depletion decreases light induced c-fos in the rat suprachiasmatic nucleus. *Neuroreport* 11:1021-4.

Mrosovsky N (1991) Double-pulse experiments with nonphotic and photic phase-shifting stimuli. *J Biol Rhythms* 6:167-79.

Moyer RW, Kennaway DJ, Ferguson SA, Dijkstra YP (1997) Quipazine and light have similar effects on c-fos induction in the rat suprachiasmatic nucleus. *Brain Res.* 765:337-42.

Mrosovsky N, Reeb SG, Honrado GI, Salmon PA (1989) Behavioural entrainment of circadian rhythms. *Experientia* 45:696-702.

Mullins UL, Gianutsos G, Eison AS (1999) Effects of antidepressants on 5-HT₇ receptor regulation in the rat hypothalamus. *Neuropsychopharmacology* 21:352-67.

N

Nagano M, Adachi A, Nakahama K, Nakamura T, Tamada M, Meyer-Bernstein E, Sehgal A, Shigeyoshi Y (2003) An abrupt shift in the day/night cycle causes desynchrony in the mammalian circadian center. *J Neurosci.* 23:6141-6151.

Nagoshi E, Saini C, Bauer C, Laroche T, Naef F, Schibler U (2004) Circadian gene expression in individual fibroblasts: cell-autonomous and self-sustained oscillators pass time to daughter cells. *Cell* 119:693-705.

Nakamura W, Honma S, Shirakawa T, Honma K (2001) Regional pacemakers composed of multiple oscillator neurons in the rat suprachiasmatic nucleus. *Eur J Neurosci.* 14:666-74.

Nayak SV, Ronde P, Spier AD, Lummis SC, Nichols RA (1999) Calcium changes induced by presynaptic 5-hydroxytryptamine-3 serotonin receptors on isolated terminals from various regions of the rat brain. *Neuroscience* 91:107-17.

Newman GC, Hospod FE (1986) Rhythm of suprachiasmatic nucleus 2-deoxyglucose uptake *in vitro*. *Brain Res.* 381:345-50.

Nishino H, Koizumi K (1977) Responses of neurons in the suprachiasmatic nuclei of the hypothalamus to putative transmitters. *Brain Res.* 120:167-72.

Nishiwaki T, Okamura H, Kanemasa K, Inatomi T, Ibata Y, Fukuhara C, Inouye ST (1995) Differences of somatostatin mRNA in the rat suprachiasmatic nucleus under light-dark and constant dark conditions: an analysis by *in situ* hybridization. *Neurosci Lett.* 197:231-4.

Nonaka H, Emoto N, Ikeda K, Fukuya H, Rohman MS, Raharjo SB, Yagita K, Okamura H, Yokoyama M (2001) Angiotensin II induces circadian gene expression of clock genes in cultured vascular smooth muscle cells. *Circulation* 104:1746-8.

O

Oishi K, Sakamoto K, Okada T, Nagase T, Ishida N (1998) Antiphase circadian expression between BMAL1 and period homologue mRNA in the suprachiasmatic nucleus and peripheral tissues of rats. *Biochem Biophys Res Commun* 253:199-203.

Oishi K, Fukui H, Ishida N (2000) Rhythmic expression of BMAL1 mRNA is altered in Clock mutant mice: differential regulation in the suprachiasmatic nucleus and peripheral tissues. *Biochem Biophys Res Commun* 268:164-71.

Okamura H, Ibata Y (1994) GRP immunoreactivity shows a day-night difference in the suprachiasmatic nuclear soma and efferent fibers: comparison to VIP immunoreactivity. *Neurosci Lett.* 181:165-8.

Okamura H, Murakami S, Fukui K, Uda K, Kawamoto K, Kawashima S, Yanaihara N, Ibata Y (1986) Vasoactive intestinal peptide- and peptide histidine isoleucine amide-like immunoreactivity colocalize with vasopressin-like immunoreactivity in the canine hypothalamo-neurohypophysial neuronal system. *Neurosci Lett.* 69:227-32.

Okamura H, Miyake S, Sumi Y, Yamaguchi S, Yasui A, Muijtjens M, Hoeijmakers JH, van der Horst GT (1999) Photic induction of mPer1 and mPer2 in cry-deficient mice lacking a biological clock. *Science* 286:2531-4.

Oksenberg D, Peroutka SJ (1988) Antagonism of 5-hydroxytryptamine1A (5-HT1A) receptor-mediated modulation of adenylate cyclase activity by pindolol and propranolol isomers. *Biochem Pharmacol.* 37:3429-33.

Onishi H, Yamaguchi S, Yagita K, Ishida Y, Dong X, Kimura H, Jing Z, Ohara H, Okamura H (2002) Rev-erbalpha gene expression in the mouse brain with special emphasis on its circadian profiles in the suprachiasmatic nucleus. *J Neurosci Res.* 68:551-7.

Ozaki N, Duncan WC Jr, Johnson KA, Wehr TA (1993) Diurnal variations of serotonin and dopamine levels in discrete brain regions of Syrian hamsters and their modification by chronic clorgyline treatment. *Brain Res.* 627:41-8.

P

Parent A, Descarries L, Beaudet A (1981) Organization of ascending serotonin systems in the adult rat brain. A radioautographic study after intraventricular administration of [³H]5-hydroxytryptamine. *Neuroscience* 6:115-38.

Park HT, Baek SY, Kim BS, Kim JB, Kim JJ (1993) Calcitonin gene-related peptide-like immunoreactive (CGRPI) elements in the circadian system of the mouse: an immunohistochemistry combined with retrograde transport study. *Brain Res.* 629:335-41.

Paul KN, Fukuhara C, Tosini G, Albers HE (2003) Transduction of light in the suprachiasmatic nucleus: evidence for two different neurochemical cascades regulating the levels of Per1 mRNA and pineal melatonin. *Neuroscience* 119:137-44.

Pauwels PJ (1997) 5-HT 1B/D receptor antagonists. *Gen Pharmacol.* 29:293-303.

Penev PD, Zee PC, Turek FW (1994) Monoamine depletion blocks triazolam-induced phase advances of the circadian clock in hamsters. *Brain Res.* 637:255-61.

Perreau-Lenz S, Kalsbeek A, Garidou ML, Wortel J, van der Vliet J, van Heijningen C, Simonneaux V, Pevet P, Buijs RM (2003) Suprachiasmatic control of melatonin synthesis in rats: inhibitory and stimulatory mechanisms. *Eur J Neurosci.* 17:221-8.

Perreau-Lenz S, Kalsbeek A, Pevet P, Buijs RM (2004) Glutamatergic clock output stimulates melatonin synthesis at night. *Eur J Neurosci.* 19:318-24.

Peters RV, Aronin N, Schwartz WJ (1996) c-Fos expression in the rat intergeniculate leaflet: photic regulation, co-localization with Fos-B, and cellular identification. *Brain Res.* 728:231-41.

Pickard GE (1985) Bifurcating axons of retinal ganglion cells terminate in the hypothalamic suprachiasmatic nucleus and the intergeniculate leaflet of the thalamus. *Neurosci Lett.* 55:211-7.

Pickard GE, Rea MA (1997) TFMPP, a 5HT1B receptor agonist, inhibits light-induced phase shifts of the circadian activity rhythm and c-Fos expression in the mouse suprachiasmatic nucleus. *Neurosci Lett.* 231:95-8.

Pickard GE, Weber ET, Scott PA, Riberdy AF, Rea MA (1996) 5HT1B receptor agonists inhibit light-induced phase shifts of behavioral circadian rhythms and expression of the immediate-early gene c-fos in the suprachiasmatic nucleus. *J Neurosci.* 16:8208-20.

Pickard GE, Smith BN, Belenky M, Rea MA, Dudek FE, Sollars PJ (1999) 5-HT1B receptor-mediated presynaptic inhibition of retinal input to the suprachiasmatic nucleus. *J Neurosci.* 19:4034-45.

Piggins HD, Rusak B (1997) Effects of microinjections of substance P into the suprachiasmatic nucleus region on hamster wheel-running rhythms. *Brain Res Bull.* 42:451-5.

Piggins HD, Antle MC, Rusak B (1995) Neuropeptides phase shift the mammalian circadian pacemaker. *J Neurosci.* 15:5612-22.

Piggins HD, Marchant EG, Goguen D, Rusak B (2001) Phase-shifting effects of pituitary adenylate cyclase activating polypeptide on hamster wheel-running rhythms. *Neurosci Lett.* 305:25-8.

Pitrosky B, Kirsch R, Malan A, Mocaer E, Pevet P (1999) Organization of rat circadian rhythms during daily infusion of melatonin or S20098, a melatonin agonist. *Am J Physiol.* 277:R812-28.

Pittendrigh CS (1967) Circadian systems. I. The driving oscillation and its assay in *Drosophila pseudoobscura*. *Proc Natl Acad Sci U S A* 58:1762-7.

Pittendrigh CS, Daan S, (1976) A functional analysis of circadian pacemakers in nocturnal rodents. IV. Entrainment: Pacemaker as a clock. *J Comp Physiol A* 106:291-331.

Poirel VJ, Boggio V, Dardente H, Pevet P, Masson-Pevet M, Gauer F (2003) Contrary to other non-photoc cues, acute melatonin injection does not induce immediate changes of clock gene mRNA expression in the rat suprachiasmatic nuclei. *Neuroscience* 120:745-55.

Preitner N, Damiola F, Lopez-Molina L, Zakany J, Duboule D, Albrecht U, Schibler U (2002) The orphan nuclear receptor REV-ERBalpha controls circadian transcription within the positive limb of the mammalian circadian oscillator. *Cell* 110:251-60.

Prosser RA (2003) Serotonin phase-shifts the mouse suprachiasmatic circadian clock in vitro. *Brain Res.* 966:110-5.

Prosser RA, Bergeron HE (2003) Leptin phase-advances the rat suprachiasmatic circadian clock *in vitro*. *Neurosci Lett.* 336:139-42.

Prosser RA, McArthur AJ, Gillette MU (1989) cGMP induces phase shifts of a mammalian circadian pacemaker at night, in antiphase to cAMP effects. *Proc Natl Acad Sci U S A.* 86:6812-5.

Prosser RA, Miller JD, Heller HC (1990) A serotonin agonist phase-shifts the circadian clock in the suprachiasmatic nuclei *in vitro*. *Brain Res.* 534:336-9.

Prosser RA, Heller HC, Miller JD (1992) Serotonergic phase shifts of the mammalian circadian clock: effects of tetrodotoxin and high Mg²⁺. *Brain Res.* 573:336-40.

Prosser RA, Dean RR, Edgar DM, Heller HC, Miller JD (1993) Serotonin and the mammalian circadian system: I. *In vitro* phase shifts by serotonergic agonists and antagonists. *J Biol Rhythms* 8:1-16.

Prosser RA, Edgar DM, Heller HC, Miller JD (1994a) A possible glial role in the mammalian circadian clock. *Brain Res.* 643:296-301.

Prosser RA, Macdonald ES, Heller HC (1994b) c-fos mRNA in the suprachiasmatic nuclei *in vitro* shows a circadian rhythm and responds to a serotonergic agonist. *Brain Res Mol Brain Res.* 25:151-6.

Prosser RA, Rutishauser U, Ungers G, Fedorkova L, Glass JD (2003) Intrinsic role of polysialylated neural cell adhesion molecule in photic phase resetting of the Mammalian circadian clock. *J Neurosci.* 23:652-8.

Provencio I, Cooper HM, Foster RG (1998) Retinal projections in mice with inherited retinal degeneration: implications for circadian photoentrainment. *J Comp Neurol.* 395:417-39.

Q

Quay WB (1968) Differences in circadian rhythms in 5-hydroxytryptamine according to brain region. *Am J Physiol.* 215:1448-53.

R

Ralph MR, Menaker M (1988) A mutation of the circadian system in golden hamsters. *Science* 241:1225-1227.

Ralph MR, Mrosovsky N (1992) Behavioral inhibition of circadian responses to light. *J Biol Rhythms* 7:353-9.

Ralph MR, Foster RG, Davis FC, Menaker M (1990) Transplanted suprachiasmatic nucleus determines circadian period. *Science* 247:975-978.

Rapport MM, Green AA, Page IH (1948) Serum vasoconstrictor (serotonin). IV. Isolation and characterization. *J Biol Chem.* 176:1243-1251.

Rea MA, Glass JD, Colwell CS (1994) Serotonin modulates photic responses in the hamster suprachiasmatic nuclei. *J Neurosci.* 14:3635-42.

Rea MA, Barrera J, Glass JD, Gannon RL (1995) Serotonergic potentiation of photic phase shifts of the circadian activity rhythm. *Neuroreport* 6:1417-20.

Recio J, Pevet P, Masson-Pevet M (1996) Serotonergic modulation of photically induced increase in melatonin receptor density and Fos immunoreactivity in the suprachiasmatic nuclei of the rat. *J Neuroendocrinol.* 8:839-45.

Reddy AB, Field MD, Maywood ES, Hastings MH (2002) Differential resynchronisation of circadian clock gene expression within the suprachiasmatic nuclei of mice subjected to experimental jet lag. *J Neurosci.* 22:7326-7330.

Reebs SG, Mrosovsky N (1989) Effects of induced wheel running on the circadian activity rhythms of Syrian hamsters: entrainment and phase response curve. *J Biol Rhythms* 4:39-48.

Reed HE, Meyer-Spasche A, Cutler DJ, Coen CW, Piggins HD (2001) Vasoactive intestinal polypeptide (VIP) phase-shifts the rat suprachiasmatic nucleus clock *in vitro*. *Eur J Neurosci.* 13:839-43.

Reges RV, Bonagamba LG, Nosjean A, Laguzzi R, Machado BH (2002) Involvement of NMDA receptors in the pressor response to microinjection of 5-HT₃ agonist into the NTS of awake rats. *Auton Neurosci.* 98:2-6.

Reick M, Garcia JA, Dudley C, McKnight SL (2001) NPAS2: an analog of clock operative in the mammalian forebrain. *Science* 293:506-9.

Reuss S (1996) Components and connections of the circadian timing system in mammals. *Cell Tissue Res.* 285:353-78.

Roberts C, Price GW (2001) Interaction of serotonin autoreceptor antagonists in the rat dorsal raphe nucleus: an *in vitro* fast cyclic voltammetry study. *Neurosci Lett.* 300:45-8.

Roca AL, Weaver DR, Reppert SM (1993) Serotonin receptor gene expression in the rat suprachiasmatic nuclei. *Brain Res.* 608:159-65.

Romijn HJ, Sluiter AA, Pool CW, Wortel J, Buijs RM (1996) Differences in colocalization between Fos and PHL, GRP, VIP and VP in neurons of the rat suprachiasmatic nucleus after a light stimulus during the phase delay versus the phase advance period of the night. *J Comp Neurol.* 372:1-8.

Romijn HJ, Sluiter AA, Pool CW, Wortel J, Buijs RM (1997) Evidence from confocal fluorescence microscopy for a dense, reciprocal innervation between AVP-, somatostatin-, VIP/PHI-, GRP-, and VIP/PHI/GRP-immunoreactive neurons in the rat suprachiasmatic nucleus. *Eur J Neurosci.* 9:2613-23.

Romijn HJ, Sluiter AA, Wortel J, Van Uum JF, Buijs RM (1998) Immunocytochemical evidence for a diurnal rhythm of neurons showing colocalization of VIP with GRP in the rat suprachiasmatic nucleus. *J Comp Neurol.* 391:397-405.

Ruby NF, Brennan TJ, Xie X, Cao V, Franken P, Heller HC, O'Hara BF (2002) Role of melanopsin in circadian responses to light. *Science* 298:2211-3.

Ruda MA, Coffield J, Steinbusch HW (1982) Immunocytochemical analysis of serotonergic axons in laminae I and II of the lumbar spinal cord of the cat. *J Neurosci.* 2:1660-71.

Rusak B, Meijer JH, Harrington ME (1989) Hamster circadian rhythms are phase-shifted by electrical stimulation of the geniculo-hypothalamic tract. *Brain Res.* 493:283-91.

Rusak B, Robertson HA, Wisden W, Hunt SP (1990) Light pulses that shift rhythms induce gene expression in the suprachiasmatic nucleus. *Science* 248:1237-40.

S

Sakai K, Salvetti D, Touret M, Jouvet M (1977) Afferent connections of the nucleus raphe dorsalis in the cat as visualized by the horseradish peroxidase technique. *Brain Res.* 137:11-35.

Sakanaka M, Magari S, Inoue N, Lederis K (1990) Co-localization of arginine vasopressin- and enkephalin-like immunoreactivities in nerve cells of the rat hypothalamus. *Cell Tissue Res.* 260:549-54.

Sanada K, Okano T, Fukada Y (2002) Mitogen-activated protein kinase phosphorylates and negatively regulates basic helix-loop-helix-PAS transcription factor BMAL1. *J Biol Chem.* 277:267-71.

Sato TK, Panda S, Miraglia LJ, Reyes TM, Rudic RD, McNamara P, Naik KA, FitzGerald GA, Kay SA, Hogenesch JB (2004) A functional genomics strategy reveals *Ror α* as a component of the mammalian circadian clock. *Neuron* 43:527-37.

Sawaki Y, Nihonmatsu I, Kawamura H (1984) Transplantation of the neonatal suprachiasmatic nuclei into rats with complete bilateral suprachiasmatic lesions. *Neurosci Res.* 1:67-72.

Schibler U, Sassone-Corsi P (2002) A web of circadian pacemakers. *Cell* 111:919-22.

Schuhler S, Saboureau M, Pitrosky B, Pévet P (1998) In Syrian hamsters, 5-HT fibres within the suprachiasmatic nuclei are necessary for the expression of 8-OH-DPAT induced phase-advance of locomotor activity rhythm. *Neurosci Lett.* 256:33-36.

Schuhler S, Pitrosky B, Saboureau M, Lakhdar-Ghazal N, Pévet P (1999) Role of the thalamic intergeniculate leaflet and its 5-HT afferences in the chronobiological properties of 8-OH-DPAT and triazolam in syrian hamster. *Brain Res.* 849:16-24.

Schwartz WJ, Gainer H (1977) Suprachiasmatic nucleus: use of ¹⁴C-labeled deoxyglucose uptake as a functional marker. *Science* 197:1089-1091.

Schwartz WJ, Zimmerman P (1990) Circadian timekeeping in BALB/c and C57BL/6 inbred mouse strains. *J Neurosci.* 10:3685-3694.

Schweiger U, Broocks A, Tuschl RJ, Pirke KM (1989) Serotonin turnover in rat brain during semistarvation with high-protein and high-carbohydrate diets. *J Neural Transm.* 77:131-9.

Selim M, Glass JD, Hauser UE, Rea MA (1993) Serotonergic inhibition of light-induced fos protein expression and extracellular glutamate in the suprachiasmatic nuclei. *Brain Res.* 621:181-8.

Semo M, Lupi D, Peirson SN, Butler JN, Foster RG (2003) Light-induced c-fos in melanopsin retinal ganglion cells of young and aged rodless/coneless (rd/rd cl) mice. *Eur J Neurosci.* 18:3007-17.

Senba E, Matsunaga K, Tohyama M, Noguchi K (1993) Stress-induced c-fos expression in the rat brain: activation mechanism of sympathetic pathway. *Brain Res Bull.* 31:329-44.

Servière J, Laviaille M (1996a) Le noyau suprachiasmatic: approche cellulaire du fonctionnement de l'horloge. *Pathol.Biol.* 44:497-508.

Servière J, Laviaille M (1996b) Astrocytes in the mammalian circadian clock: putative roles. *Prog Brain Res.* 111:57-73.

Sevoz-Couche C, Maisonneuve B, Hamon M, Laguzzi R (2002) Glutamate and NO mediation of the pressor response to 5-HT₃ receptor stimulation in the nucleus tractus solitarii. *Neuroreport.* 13:837-41.

Sharma VK, Chidambaram R, Subbaraj R, Chandrashekar MK (2000) Effects of restricted feeding cycle on the locomotor activity rhythm in the mouse *Mus booduga*. *Physiol Behav.* 70:81-87.

Shearman LP, Zylka MJ, Weaver DR, Kolakowski LF Jr, Reppert SM (1997) Two period homologs: circadian expression and photic regulation in the suprachiasmatic nuclei. *Neuron* 19:1261-9.

- Shearman LP, Zylka MJ, Reppert SM, Weaver DR (1999) Expression of basic helix-loop-helix/PAS genes in the mouse suprachiasmatic nucleus. *Neuroscience* 89:387-97.
- Shearman LP, Jin X, Lee C, Reppert SM, Weaver DR (2000a) Targeted disruption of the mPer3 gene: subtle effects on circadian clock function. *Mol Cell Biol.* 20:6269-75.
- Shearman LP, Sriram S, Weaver DR, Maywood ES, Chaves I, Zheng B, Kume K, Lee CC, van der Horst GT, Hastings MH, Reppert SM (2000b) Interacting molecular loops in the mammalian circadian clock. *Science* 288:1013-9.
- Shen H, Semba K (1994) A direct retinal projection to the dorsal raphe nucleus in the rat. *Brain Res.* 635:159-68.
- Shen H, Watanabe M, Tomasiewicz H, Rutishauser U, Magnuson T, Glass JD (1997) Role of neural cell adhesion molecule and polysialic acid in mouse circadian clock function. *J Neurosci.* 17:5221-9.
- Sheng M, Greenberg ME (1990) The regulation and function of c-fos and other immediate early genes in the nervous system. *Neuron* 4:477-85.
- Shibata S, Moore RY (1993) Neuropeptide Y and optic chiasm stimulation affect suprachiasmatic nucleus circadian function in vitro. *Brain Res.* 615:95-100.
- Shibata S, Oomura Y, Kita H, Hattori K (1982) Circadian rhythmic changes of neuronal activity in the suprachiasmatic nucleus of the rat hypothalamic slice. *Brain Res.* 247:154-158.
- Shibata S, Hamada T, Tominaga K, Watanabe S (1992) An *in vitro* circadian rhythm of protein synthesis in the rat suprachiasmatic nucleus under tissue culture conditions. *Brain Res.* 584:251-256.
- Shibata S, Watanabe A, Hamada T, Watanabe S (1994) Protein-synthesis inhibitor blocks (R,S)-alpha-amino-3-hydroxy-5-methylisoxazole-4-propionic acid (AMPA)-or substance P-induced phase shift of the circadian rhythm of neuronal activity in the rat suprachiasmatic nucleus in vitro. *Neurosci Lett.* 168:159-62.
- Shigeyoshi Y, Taguchi K, Yamamoto S, Takekida S, Yan L, Tei H, Moriya T, Shibata S, Loros JJ, Dunlap JC, Okamura H (1997) Light-induced resetting of a mammalian circadian clock is associated with rapid induction of the mPer1 transcript. *Cell* 91:1043-53.
- Shimizu K, Nagai K, Nakagawa H (1996) An immunotoxin, anti-VIP antibody-ricin A chain conjugate eliminates neurons in the hypothalamic suprachiasmatic nucleus selectively and abolishes the circadian rhythm of water intake. *Brain Res Bull.* 41:369-78.
- Shinohara K, Tominaga K, Isobe Y, Inouye ST (1993) Photic regulation of peptides located in the ventrolateral subdivision of the suprachiasmatic nucleus of the rat: daily variations of vasoactive intestinal polypeptide, gastrin-releasing peptide, and neuropeptide Y. *J Neurosci.* 13:793-800.
- Shinohara K, Honma S, Katsuno Y, Abe H, Honma K (1995) Two distinct oscillators in the rat suprachiasmatic nucleus in vitro. *Proc Natl Acad Sci U S A* 92:7396-400.
- Shinohara K, Hiruma H, Funabashi T, Kimura F (2000) GABAergic modulation of gap junction communication in slice cultures of the rat suprachiasmatic nucleus. *Neuroscience* 96:591-6.
- Shirakawa T, Honma S, Katsuno Y, Oguchi H, Honma KI (2000) Synchronization of circadian firing rhythms in cultured rat suprachiasmatic neurons. *Eur J Neurosci.* 12:2833-8.
- Silver R, Romero MT, Besmer HR, Leak R, Nunez JM, LeSauter J (1996a) Calbindin-D28K cells in the hamster SCN express light-induced Fos. *Neuroreport* 7:1224-8.
- Silver R, LeSauter J, Tresco PA, Lehman MN (1996b) A diffusible coupling signal from the transplanted suprachiasmatic nucleus controlling circadian locomotor rhythms. *Nature* 382:810-3.
- Singh VB, Corley KC, Phan TH, Boadle-Biber MC (1990) Increases in the activity of tryptophan hydroxylase from rat cortex and midbrain in response to acute or repeated sound stress are blocked by adrenalectomy and restored by dexamethasone treatment. *Brain Res.* 516:66-76.
- Slotten HA, Krekling S, Sicard B, Pevet P (2002) Daily infusion of melatonin entrains circadian activity rhythms in the diurnal rodent *Arvicanthis ansorgei*. *Behav Brain Res.* 133:11-9.
- Smale L, Michels KM, Moore RY, Morin LP (1990) Destruction of the hamster serotonergic system by 5,7-DHT: effects on circadian rhythm phase, entrainment and response to triazolam. *Brain Res.* 515(1-2):9-19.
- Smart CM, Biello SM (2001) WAY-100635, a specific 5-HT1A antagonist, can increase the responsiveness of the mammalian circadian pacemaker to photic stimuli. *Neurosci Lett.* 305:33-6.
- Smith BN, Sollars PJ, Dudek FE, Pickard GE (2001) Serotonergic modulation of retinal input to the mouse suprachiasmatic nucleus mediated by 5-HT1B and 5-HT7 receptors. *J Biol Rhythms* 16:25-38.
- Sprouse JS, Aghajanian GK (1986) (-)-Propranolol blocks the inhibition of serotonergic dorsal raphe cell firing by 5-HT1A selective agonists. *Eur J Pharmacol.* 128:295-8.

Sprouse J, Reynolds L, Braselton J, Schmidt A (2005) Serotonin-induced phase advances of SCN neuronal firing in vitro: a possible role for 5-HT_{5A} receptors? *Synapse* 54:111-8.

Srkalovic G, Selim M, Rea MA, Glass JD (1994) Serotonergic inhibition of extracellular glutamate in the suprachiasmatic nuclear region assessed using in vivo brain microdialysis. *Brain Res.* 656:302-8.

Stephan FK (2002) The "other" circadian system: food as a Zeitgeber. *J Biol Rhythms* 17:284-292.

Stephan FK, Zucker I (1972) Circadian rhythms in drinking behavior and locomotor activity of rats are eliminated by hypothalamic lesions. *Proc Natl Acad Sci U.S.A* 69:1583-1586.

Stokkan KA, Yamazaki S, Tei H, Sakaki Y, Menaker M (2001) Entrainment of the circadian clock in the liver by feeding. *Science* 291:490-493.

Sumova A, Maywood ES, Selva D, Ebling FJ, Hastings MH (1996) Serotonergic antagonists impair arousal-induced phase shifts of the circadian system of the syrian hamster. *Brain Res.* 709:88-96.

Sun ZS, Albrecht U, Zhuchenko O, Bailey J, Eichele G, Lee CC (1997) RIGUI, a putative mammalian ortholog of the *Drosophila* period gene. *Cell* 90:1003-11.

Swanson LW, Sawchenko PE (1980) Paraventricular nucleus: a site for the integration of neuroendocrine and autonomic mechanisms. *Neuroendocrinology* 31:410-7.

T

Takahashi H, Umeda N, Tsutsumi Y, Fukumura R, Ohkaze H, Sujino M, van der Horst G, Yasui A, Inouye ST, Fujimori A, Ohhata T, Araki R, Abe M (2003) Mouse dexamethasone-induced RAS protein 1 gene is expressed in a circadian rhythmic manner in the suprachiasmatic nucleus. *Brain Res Mol Brain Res.* 110:1-6.

Takahashi JS, Pinto LH, Vitaterna MH (1994) Forward and reverse genetic approaches to behavior in the mouse. *Science* 264:1724-33.

Takahashi Y, Okamura H, Yanaihara N, Hamada S, Fujita S, Ibata Y (1989) Vasoactive intestinal peptide immunoreactive neurons in the rat suprachiasmatic nucleus demonstrate diurnal variation. *Brain Res.* 497:374-7.

Takahashi JS, Turek FW, Moore RY (2001) *Circadian clocks*, Volume 12, *Handbook of Behavioral Neurobiology*. New York: Kluwer Academic / Plenum Publishers.

Takatsuji K, Miguel-Hidalgo JJ, Tohyama M (1991) Substance P-immunoreactive innervation from the retina to the suprachiasmatic nucleus in the rat. *Brain Res.* 568:223-9.

Takumi T, Matsubara C, Shigeyoshi Y, Taguchi K, Yagita K, Maebayashi Y, Sakakida Y, Okumura K, Takashima N, Okamura H (1998) A new mammalian period gene predominantly expressed in the suprachiasmatic nucleus. *Genes Cells* 3:167-76.

Tamada Y, Tanaka M, Munekawa K, Hayashi S, Okamura H, Kubo T, Hisa Y, Ibata Y (1998) Neuron-glia interaction in the suprachiasmatic nucleus: a double labeling light and electron microscopic immunocytochemical study in the rat. *Brain Res Bull.* 45:281-7.

Tamaru T, Isojima Y, Yamada T, Okada M, Nagai K, Takamatsu K (2000) Light and glutamate-induced degradation of the circadian oscillating protein BMAL1 during the mammalian clock resetting. *J Neurosci.* 20:7525-30.

Tanaka M, Ichitani Y, Okamura H, Tanaka Y, Ibata Y (1993) The direct retinal projection to VIP neuronal elements in the rat SCN. *Brain Res Bull.* 31:637-40.

Tanaka M, Okamura H, Matsuda T, Shigeyoshi Y, Hisa Y, Chihara K, Ibata Y (1996) Somatostatin neurons form a distinct peptidergic neuronal group in the rat suprachiasmatic nucleus: a double labeling *in situ* hybridization study. *Neurosci Lett.* 215:119-22.

Tang KC, Pan JT (1993) Stimulatory effects of bombesin-like peptides on suprachiasmatic neurons in brain slices. *Brain Res.* 614:125-30.

Tei H, Okamura H, Shigeyoshi Y, Fukuhara C, Ozawa R, Hirose M, Sakaki Y (1997) Circadian oscillation of a mammalian homologue of the *Drosophila* period gene. *Nature* 389:512-6.

Thapan K, Arendt J, Skene DJ (2001) An action spectrum for melatonin suppression: evidence for a novel non-rod, non-cone photoreceptor system in humans. *J Physiol.* 535:261-7.

Thresher RJ, Vitaterna MH, Miyamoto Y, Kazantsev A, Hsu DS, Petit C, Selby CP, Dawut L, Smithies O, Takahashi JS, Sancar A (1998) Role of mouse cryptochrome blue-light photoreceptor in circadian photoresponses. *Science* 282:1490-4.

Tischkau SA, Mitchell JW, Tyan SH, Buchanan GF, Gillette MU (2003) Ca²⁺/cAMP response element-binding protein (CREB)-dependent activation of *Per1* is required for light-induced signaling in the suprachiasmatic nucleus circadian clock. *J Biol Chem.* 278:718-23.

Tominaga K, Shinohara K, Otori Y, Fukuhara C, Inouye ST (1992a) Circadian rhythms of vasopressin content in the suprachiasmatic nucleus of the rat. *Neuroreport* 3:809-12.

Tominaga K, Shibata S, Ueki S, Watanabe S (1992b) Effects of 5-HT_{1A} receptor agonists on the circadian rhythm of wheel-running activity in hamsters. *Eur J Pharmacol.* 214:79-84.

Tominaga K, Geusz ME, Michel S, Inouye ST (1994) Calcium imaging in organotypic cultures of the rat suprachiasmatic nucleus. *Neuroreport* 5:1901-5.

Tosini G, Menaker M (1996) Circadian rhythms in cultured mammalian retina. *Science* 272:419-21.

Tournier BB, Menet JS, Dardente H, Poirel VJ, Malan A, Masson-Pévet M, Pévet P, Vuillez P (2003) Photoperiod differentially regulates clock genes' expression in the suprachiasmatic nucleus of Syrian hamster. *Neuroscience* 118:317-322.

Trulson ME, Jacobs BL (1979) Raphe unit activity in freely moving cats: correlation with level of behavioral arousal. *Brain Res.* 163:135-50.

Twarog BM, Page IH (1953) Serotonin content of some mammalian tissues and urine and a method for its determination. *Am J Physiol.* 175:157-61.

U

Ueda HR, Chen W, Adachi A, Wakamatsu H, Hayashi S, Takasugi T, Nagano M, Nakahama K, Suzuki Y, Sugano S, Iino M, Shigeyoshi Y, Hashimoto S (2002) A transcription factor response element for gene expression during circadian night. *Nature* 418:534-9.

V

van den Pol A, Tsujimoto KL (1985) Neurotransmitters of the hypothalamic suprachiasmatic nucleus: immunocytochemical analysis of 25 neuronal antigens. *Neuroscience* 15:1049-1086.

van den Pol AN (1980) The hypothalamic suprachiasmatic nucleus of rat: intrinsic anatomy. *J Comp Neurol.* 191:661-702.

van den Pol AN, Finkbeiner SM, Cornell-Bell AH (1992) Calcium excitability and oscillations in suprachiasmatic nucleus neurons and glia in vitro. *J Neurosci.* 12:2648-64.

van der Horst GT, Muijtjens M, Kobayashi K, Takano R, Kanno S, Takao M, de Wit J, Verkerk A, Eker AP, van Leenen D, Buijs R, Bootsma D, Hoeijmakers JH, Yasui A (1999) Mammalian *Cry1* and *Cry2* are essential for maintenance of circadian rhythms. *Nature* 398:627-30.

van der Zee EA, Streefland C, Strosberg AD, Schroder H, Luiten PG (1991) Colocalization of muscarinic and nicotinic receptors in cholinergic neurons of the suprachiasmatic region in young and aged rats. *Brain Res.* 542:348-52.

Vandesande F, Dierickx K, DeMey J (1975) Identification of the vasopressin-neurophysin producing neurons of the rat suprachiasmatic nuclei. *Cell Tissue Res.* 156:377-380.

van Esseveldt KE, Lehman MN, Boer GJ (2000) The suprachiasmatic nucleus and the circadian time-keeping system revisited. *Brain Res Rev.* 33:34-77.

van Hooft JA, Vijverberg HP (2000) 5-HT₃ receptors and neurotransmitter release in the CNS: a nerve ending story? *Trends Neurosci.* 23:605-10.

Van Reeth O, Turek FW (1989) Stimulated activity mediates phase shifts in the hamster circadian clock induced by dark pulses or benzodiazepines. *Nature* 339:49-51.

Vansteensel MJ, Yamazaki S, Albus H, Deboer T, Block GD, Meijer JH (2003) Dissociation between circadian *Per1* and neuronal and behavioral rhythms following a shifted environmental cycle. *Curr Biol* 13:1538-1542.

Varcoe TJ, Kennaway DJ, Voultsios A (2003) Activation of 5-HT_{2C} receptors acutely induces *Per* gene expression in the rat suprachiasmatic nucleus at night. *Brain Res Mol Brain Res.* 119:192-200.

Vielhaber E, Eide E, Rivers A, Gao ZH, Virshup DM (2000) Nuclear entry of the circadian regulator *mPER1* is controlled by mammalian casein kinase I epsilon. *Mol Cell Biol.* 20:4888-99.

Vitaterna MH, King DP, Chang AM, Kornhauser JM, Lowrey PL, McDonald JD, Dove WF, Pinto LH, Turek FW, Takahashi JS (1994) Mutagenesis and mapping of a mouse gene, *Clock*, essential for circadian behavior. *Science* 264:719-25.

Vivien-Roels B, Malan A, Rettori MC, Delagrange P, Jeannot JP, Pévet P (1999) Daily variations in pineal melatonin concentrations in inbred and outbred mice. *J Biol Rhythms* 13:403-409.

von Gall C, Noton E, Lee C, Weaver DR (2003) Light does not degrade the constitutively expressed *BMAL1* protein in the mouse suprachiasmatic nucleus. *Eur J Neurosci.* 18:125-33.

Vrang N and Mikkelsen JD (1996) Afferent connections of the intergeniculate leaflet of the Golden hamster: a combined retrograde and anterograde tracing study. *Soc Neurosci Abstr.* 22:1139.

Vuillez P, Jacob N, Teclerian-Mesbah R, Van Rossum A, Vivien-Roels B, Pévet P (1998) Effect of NMDA receptor antagonist MK-801 on light-induced *Fos* expression in the suprachiasmatic nuclei and on melatonin production in the Syrian hamster. *J Neuroendocrinol.* 10:671-7.

W

Wagner S, Castel M, Gainer H, Yarom Y (1997) GABA in the mammalian suprachiasmatic nucleus and its role in diurnal rhythmicity. *Nature* 387:598-603.

Wakamatsu H, Yoshinobu Y, Aida R, Moriya T, Akiyama M, Shibata S (2001) Restricted-feeding-induced anticipatory activity rhythm is associated with a phase-shift of the expression of mPer1 and mPer2 mRNA in the cerebral cortex and hippocampus but not in the suprachiasmatic nucleus of mice. *Eur J Neurosci*. 13:1190-1196.

Wang Y, Ramage AG, Jordan D (1998) Presynaptic 5-HT₃ receptors evoke an excitatory response in dorsal vagal preganglionic neurones in anaesthetized rats. *J Physiol*. 509:683-94.

Watts AG, Swanson LW (1987) Efferent projections of the suprachiasmatic nucleus: II. Studies using retrograde transport of fluorescent dyes and simultaneous peptide immunohistochemistry in the rat. *J Comp Neurol*. 258:230-52.

Watts AG, Swanson LW, Sanchez-Watts G (1987) Efferent projections of the suprachiasmatic nucleus: I. Studies using anterograde transport of Phaseolus vulgaris leucoagglutinin in the rat. *J Comp Neurol*. 258:204-29.

Weber ET, Rea MA (1997) Neuropeptide Y blocks light-induced phase advances but not delays of the circadian activity rhythm in hamsters. *Neurosci Lett*. 231:159-62.

Weber ET, Gannon RL, Rea MA (1998) Local administration of serotonin agonists blocks light-induced phase advances of the circadian activity rhythm in the hamster. *J Biol Rhythms* 13:209-18.

Wee R, Castrucci AM, Provencio I, Gan L, Van Gelder RN (2002) Loss of photic entrainment and altered free-running circadian rhythms in *math5*^{-/-} mice. *J Neurosci*. 22:10427-33.

Welsh DK, Reppert SM (1996) Gap junctions couple astrocytes but not neurons in dissociated cultures of rat suprachiasmatic nucleus. *Brain Res*. 706:30-36.

Welsh DK, Logothetis DE, Meister M, Reppert SM (1995) Individual neurons dissociated from rat suprachiasmatic nucleus express independently phased circadian firing rhythms. *Neuron* 14:697-706.

Welsh DK, Yoo SH, Liu AC, Takahashi JS, Kay SA (2004) Bioluminescence imaging of individual fibroblasts reveals persistent, independently phased circadian rhythms of clock gene expression. *Curr Biol*. 14:2289-95.

Wickland CR, Turek FW (1991) Phase-shifting effects of acute increases in activity on circadian locomotor rhythms in hamsters. *Am J Physiol*. 261:R1109-17.

Wollnik F, Bihler S (1996) Strain differences in the distribution of arginine-vasopressin- and neuropeptide Y-immunoreactive neurons in the suprachiasmatic nucleus of laboratory rats. *Brain Res*. 724:191-9.

Wollnik F, Turek FW (1989) SCN lesions abolish ultradian and circadian components of activity rhythms in LEW/Ztm rats. *Am J Physiol*. 256:R1027-39.

Wollnik F, Brysch W, Uhlmann E, Gillardon F, Bravo R, Zimmermann M, Schlingensiepen KH, Herdegen T (1995) Block of c-Fos and JunB expression by antisense oligonucleotides inhibits light-induced phase shifts of the mammalian circadian clock. *Eur J Neurosci*. 7:388-93.

Y

Yagita K, Tamanini F, Yasuda M, Hoeijmakers JH, van der Horst GT, Okamura H (2002) Nucleocytoplasmic shuttling and mCRY-dependent inhibition of ubiquitylation of the mPER2 clock protein. *EMBO J*. 21:1301-14.

Yamaguchi S, Isejima H, Matsuo T, Okura R, Yagita K, Kobayashi M, Okamura H (2003) Synchronization of cellular clocks in the suprachiasmatic nucleus. *Science* 302:1408-12.

Yamazaki S, Numano R, Abe M, Hida A, Takahashi R, Ueda M, Block GD, Sakaki Y, Menaker M, Tei H (2000) Resetting central and peripheral circadian oscillators in transgenic rats. *Science* 288:682-5.

Yamazaki S, Alones V, Menaker M (2002) Interaction of the retina with suprachiasmatic pacemakers in the control of circadian behavior. *J Biol Rhythms* 17:315-29.

Yan L, Silver R (2002) Differential induction and localization of mPer1 and mPer2 during advancing and delaying phase shifts. *Eur J Neurosci*. 16:1531-40.

Yan L, Takekida S, Shigeyoshi Y, Okamura H (1999) Per1 and Per2 gene expression in the rat suprachiasmatic nucleus: circadian profile and the compartment-specific response to light. *Neuroscience* 94:141-50.

Yannielli PC, McKinley Brewer J, Harrington ME (2002) Is novel wheel inhibition of per1 and per2 expression linked to phase shift occurrence? *Neuroscience* 112:677-85.

Ying SW, Rusak B (1994) Effects of serotonergic agonists on firing rates of photically responsive cells in the hamster suprachiasmatic nucleus. *Brain Res*. 651:37-46.

Ying SW, Rusak B (1997) 5-HT₇ receptors mediate serotonergic effects on light-sensitive suprachiasmatic nucleus neurons. *Brain Res*. 755:246-54.

Yokota SI, Horikawa K, Akiyama M, Moriya T, Ebihara S, Komuro G, Ohta T, Shibata S (2000) Inhibitory action of brotizolam on circadian and light-induced *per1* and *per2* expression in the hamster suprachiasmatic nucleus. *Br J Pharmacol.* 131:1739-47.

Young WS 3rd, Kovacs K, Lolait SJ (1993) The diurnal rhythm in vasopressin V1a receptor expression in the suprachiasmatic nucleus is not dependent on vasopressin. *Endocrinology* 133:585-90.

Young ME, Razeghi P, Taegtmeier H (2001) Clock genes in the heart: characterization and attenuation with hypertrophy. *Circ Res.* 88:1142-50.

Z

Zheng B, Larkin DW, Albrecht U, Sun ZS, Sage M, Eichele G, Lee CC, Bradley A (1999) The *mPer2* gene encodes a functional component of the mammalian circadian clock. *Nature* 400:169-73.

Zheng B, Albrecht U, Kaasik K, Sage M, Lu W, Vaishnav S, Li Q, Sun ZS, Eichele G, Bradley A, Lee CC (2001) Nonredundant roles of the *mPer1* and *mPer2* genes in the mammalian circadian clock. *Cell* 105:683-94.

Zifa E, Fillion G (1992) 5-Hydroxytryptamine receptors. *Pharmacol Rev.* 44:401-58.

Zhou D, Huether G, Wiltfang J, Hajak G, Ruther E (1996) Serotonin transporters in the rat frontal cortex: lack of circadian rhythmicity but down-regulation by food restriction. *J Neurochem.* 67:656-61.

Zylka MJ, Shearman LP, Weaver DR, Reppert SM (1998) Three period homologs in mammals: differential light responses in the suprachiasmatic circadian clock and oscillating transcripts outside of brain. *Neuron* 20:1103-10.

Publications and scientific posters

PUBLICATIONS AND SCIENTIFIC POSTERS

Publications

Challet E, Caldelas I, Graff C, Pévet P (2003)

Feeding cues alter clock gene oscillations and photic responses in the suprachiasmatic nuclei of mice exposed to a light/dark cycle.

Biol Chem. 384:711-719.

Mendoza J, Graff C (co-first author), Dardente H, Pévet P, Challet E (2005)

Synchronization of the molecular clockwork by light- and food-related cues in mammals.

J Neurosci. 25:1514-22.

Graff C, Kohler M, Pévet P, Wollnik F (2005)

Involvement of the retinohypothalamic tract in the photic-like effects of the 5-HT agonist quipazine in the rat.

Neuroscience 2005 135(1):273-283.

Graff C, Challet C, Pévet P and Wollnik F

5-HT₃ receptor-mediated photic-like responses of the circadian clock in the rat

Submitted

Scientific posters

Graff C, Pévet P, Wollnik F (2002)

Photic-like effects of quipazine do not involve the genicohypothalamic tract.

“Deutsche Forschungsgemeinschaft” Congress on circadian rhythms (Munich, Germany).

Graff C, Pévet P, Wollnik F (2002)

Photic-like effects of quipazine do not involve the genicohypothalamic tract.

Chronobiology Summer School at the Max-Planck Research Centre for Ornithology (Andechs, Germany).

Graff C, Pévet P, Wollnik F (2003)

Localization of serotonergic receptors mediating photic-like response of the SCN to *quipazine*.

Congress of the “Gesellschaft für Biochemie und Molekularbiologie“ (Mosbach, Germany).

Graff C, Pévet P, Wollnik F (2003)

Localization of serotonergic receptors mediating photic-like response of the SCN to *quipazine*.

Congress of the German Clock Club Society (Frankfurt, Germany).

Graff C, Pévet P, Wollnik F (2004)

Localization of serotonergic receptors mediating photic-like response of the SCN to *quipazine*.

Neurex annual meeting (Freiburg, Germany).

Graff C, Pévet P, Wollnik F (2004)

Localization of serotonergic receptors mediating photic-like response of the SCN to *quipazine*.

“Society for Research in Biological Rhythm” Congress (Vancouver, Canada).

Graff C, Challet E, Pévet P, Wollnik F (2005)

5-HT₃ receptor mediates photic-like effect of quipazine on locomotor activity rhythm in rat.

Neurex annual meeting (Strasbourg, France).

Graff C, Challet E, Pévet P, Wollnik F (2005)

5-HT₃ receptor mediates photic-like effect of quipazine on locomotor activity rhythm in rat.

Congress of the “Société Française de Chronobiologie” (Strasbourg, France).

Graff C, Challet E, Pévet P, Wollnik F (2005)

5-HT₃ receptor mediates photic-like effect of quipazine on locomotor activity rhythm in rat.

Congress of the “European Pineal and Biological Rhythms Society” (Frankfurt, Germany).

GRAFF Caroline
4, Boulevard de la Dordogne
67000 STRASBOURG
Tel: 00333-88-24-14-17
E-mail: carograff@yahoo.fr



Geboren am 30.10.1977 in Strasbourg

AUSBILDUNG

- Seit Januar 2002 Doktorandin an der Universität "Louis Pasteur" in Strasbourg und an der Universität Stuttgart (Europäische Kollaboration)
Mitglied der Europäischen Doktorandenschule (Collège Doctorale Européen, Strasbourg)
Verteidigung im November 2005
- 2000 – 2001 DEA in Neurowissenschaften (ULP, Strasbourg)
- 1997 – 2000 DEUG in Biophysikalischer Chemie, Hauptstudium in Biochemie und Neurowissenschaften (ULP, Strasbourg)
- 1995 – 1997 Medizinische Hochschule (ULP, Strasbourg)
- 1995 Baccalaureate in Wissenschaften Schwerpunkt Biologie in Haguenau, Frankreich

TRAINING

- Doktorat** Institut für Neurowissenschaften, Labor der Neurobiologie von Rhythmen (ULP, Strasbourg), Leiter Dr. P. Pévet und Universität Stuttgart, Abteilung Tierphysiologie, Leiter Prof. Dr. F. Wollnik
- Seit
Januar 2002 *Titel: Photische und nicht-photische Inputs der Suprachiasmatischen Nuclei der Ratte: Die Rolle des 5-HT Systems.*
- Literaturrecherchen und Analysen von wissenschaftlicher Relevanz für das Projekt
 - Etablierung verschiedener Techniken (elektrolytische und neurotoxische Läsionen von Gehirnstrukturen, Klonierung des 5-HT₃ Rezeptors), Koordination des Projekts zwischen beiden Labors, Planung von Versuchen mit einem technischen Assistenten, Beschaffung von Produkten und Aufsicht über Lagerbestände
 - Ergebnisanalysen und Interpretation
 - Ergebnisdiskussionen und Präsentationen auf internationalen Kongressen und Publikationen in wissenschaftlichen Fachzeitschriften
- DEA** Institut für Neurowissenschaften, Labor der Neurobiologie von Rhythmen (ULP, Strasbourg) unter Anleitung durch Dr. E. Challet
- September 2000
-Juni 2001 *Titel: In vivo Regulation von Uhrengenen in den Suprachiasmatischen Nuclei: Effekt von kalorischer Restriktion.*
- Laborpraktikum** Institut für Neurowissenschaften, Labor der Neurobiologie von Rhythmen (ULP, Strasbourg) unter Anleitung durch Dr. P. Vuillez
- April-Mai 2000 Projekt über die Integration der Photoperiode durch das „intergeniculate leaflet“.

PUBLIKATIONEN UND POSTERPRÄSENTATIONEN

- Publikationen Challet E, Caldelas I, **Graff C**, Pévet P. *Feeding cues alter clock gene oscillations and photic responses in the suprachiasmatic nuclei of mice exposed to a light/dark cycle*. Biol Chem. 2003 384:711-9.
Mendoza J, **Graff C (Ko-Erstautor)**, Dardente H, Pévet P, Challet E. *Synchronization of the molecular clockwork by light- and food-related cues in mammals*. J Neurosci. 2005 25:1514-22.
Graff C, Kohler M, Pévet P, Wollnik F. *Involvement of the retinohypothalamic tract in the photic-like effects of the 5-HT agonist quipazine in the rat*. Neuroscience 2005 135(1):273-283.
Graff C, Challet C, Pévet P and Wollnik F. *5-HT₃ receptor-mediated photic-like responses of the circadian clock in the rat*. Submitted
- Posterpräsentationen Kongress des Schwerpunktprogramms „Circadiane Rhythmen“ der Deutschen Forschungsgemeinschaft (München, Deutschland). *Photic-like effects of Quipazine does not involve the genicohypothalamic tract*. **Erstautor**
Kongress der “Society for Research in Biological Rhythm” (Vancouver, Kanada). *Localization of serotonergic receptors mediating photic-like response of the SCN to quipazine*. **Erstautor**
Kongress der “Société Française de Chronobiologie” (Strasbourg, Frankreich). *5-HT₃ receptor mediates photic-like effect of quipazine on locomotor activity rhythm in rat*. **Erstautor**

SACHTENNTNISSE

- Techniken *In vivo*: Telemetrie, Chirurgie: elektrolytische and neurotoxische Läsionen von Gehirnstrukturen, Pharmakologie: 5-HT Agonisten und Antagonisten
Zelluläre Techniken: Klassische Färbungen, Immunhistochemie
Molekulare Techniken: Klonierung des 5-HT₃ Receptors, *in situ* Hybridisierung, RT-PCR
- Zertifikate Tierschutzgerechter Umgang mit Versuchstieren (FELASA) Tierärztliche Hochschule Hannover, Deutschland
Erste Hilfe, Rotes Kreuz, Haguenau, France
- Sprachen Flüssiges Deutsch in Wort und Schrift
Gutes Englisch in Wort und Schrift
- Computerkenntnisse Sachkenntnisse von Standardprogrammen (Word, Excel, Power Point, Photoshop), Analyseprogrammen (Soft Imaging, Biocom), Statistikprogrammen (SigmaPlot, Statistica) und Literaturdatenbankprogrammen (EndNote, PubMed)

REFERENZEN

- Dr. Paul Pévet Laboratoire de neurobiologie des rythmes ; Centre de neurochimie
5, rue Blaise Pascale ; F-67084 Strasbourg
Tel: 00333-88-45-66-08 ; e-mail: pevet@neurochem.u-strasbg.fr
- Prof. Dr. Franziska Wollnik Universität Stuttgart; Biologisches Institut; Abteilung Tierphysiologie
Pfaffenwaldring 57; D-70550 Stuttgart
Tel: 0049-711-685-5001; e-mail: franziska.wollnik@bio.uni-stuttgart.de

HOBBIES

Musik, Moderner Jazztanz, Philatelie