

Dual Wavelength Heterodyne Interferometry for Rough Surface Measurements

E. Fischer, Z. Sodnik, Th. Ittner and H.J. Tiziani

Institut für Technische Optik, Universität Stuttgart
Pfaffenwaldring 9, D 7000 - Stuttgart 80, Fed. Rep. Germany

ABSTRACT

For interferometric topography measurements of optically rough surfaces dual wavelength heterodyne interferometry (DWHI) is a powerful tool. A DWHI system based on a two-wavelength HeNe laser and a matched grating technique is described. This set-up improves system stability and allows a simple heterodyne frequency generation.

1. INTRODUCTION

Applying interferometric technique for the analysis of optically rough surfaces two serious problems arise. First measurements become difficult or impossible due to the speckle effect. Second when using a reflexion set-up the ambiguity range of the measurements is limited to a half of the laser wavelength. To overcome the disadvantages interferometer with grazing incidence¹, as well as with increased laser wavelength² were developed, alternatively two wavelength interferometry is used. By applying two wavelengths simultaneously to the object the sensitivity is reduced to an effective wavelength^{3,4} given by $\lambda_{eq} = \lambda_1 \cdot \lambda_2 / |\lambda_1 - \lambda_2|$. Fercher et al.⁵ described a two wavelength heterodyne speckle interferometer where the phase of the effective wavelength must be evaluated from two independent detector signals. In this paper a scanning dual wavelength heterodyne technique is described, that generates a low frequency detection signal with a phase shift that corresponds to the effective wavelength.

2. PRINCIPLE OF A MATCHED GRATING SET-UP

Dual wavelength heterodyne interferometry (DWHI) bases on two independent, simultaneously and coaxial working heterodyne interferometers with different frequencies ν_1 and ν_2 and different heterodyne frequencies f_1 and f_2 . The phase of the beat frequency $f_1 - f_2$ depends on the synthetic wavelength λ_{eq} and can therefore be examined for distance evaluation⁶.

In fig. 1 a multi-wavelength HeNe laser is shown which emits simultaneously at 632.8 and 640.1 nm leading to a λ_{eq} of about 56 μm . An acousto-optical modulator (AOM) driven with $f_d = 40$ MHz is used to split and frequency shift part of the light to be used as reference beams. In the first diffraction order one gets light with frequencies $\nu_1 + f_d$ and $\nu_2 + f_d$ for the two laser wavelengths λ_1, λ_2 . The reference light passes first a high spatial frequency dispersion grating G. It is designed such that the diffraction angle difference $\Delta\alpha$ between $\nu_1 + f_d$ and $\nu_2 + f_d$ is the same as the first order diffraction angle of a following low spatial frequency grating RG. The second motor driven grating leads to a frequency shift f_m of the diffracted light in the first order. Due to appropriate adjustment, the 1. order diffraction of $\nu_1 + f_1 = \nu_1 + f_d + f_m$ and 0. order of $\nu_2 + f_2 = \nu_2 + f_d$ become parallel after passing RG as shown in fig. 1. The reference beat frequency $f_m = f_1 - f_2$ is generated by the rotation of an angle encoder. In our experiment we found 20KHz

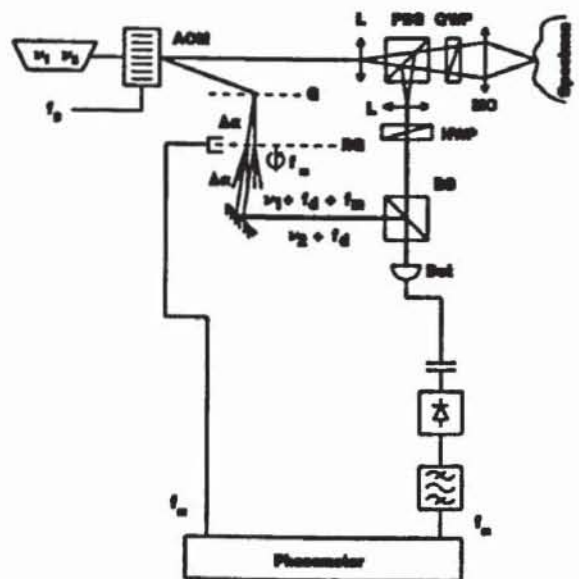

fig. 1 experimental set-up

to be most appropriate. This frequency can be directly applied as reference signal to a phase meter, e.g. lock-in-amplifier (LIA).

After passing a lens (L), a polarizing beam splitter (PBS) and a quarter-wave plate (QWP) the object beams are focused onto the specimen under test by a microscope objective (MO) as shown in fig. 1. The QWP is passed a second time by back travelling light thus it is reflected at the PBS. The beat of the two heterodyne signals can be observed after demodulating the amplitude modulated detector output. After DC cut off, demodulation and bandpass filtering one gets

$$u(t) = U_0 \cdot \cos(2\pi(f_2 - f_1)t - 4\pi \cdot d / \lambda_{eq} + \varphi_0) \quad (1)$$

Phase shift of this term corresponds to the effective wavelength. The demodulated and bandpass filtered signal is finally fed to the LIA.

3. RESULTS

The results were obtained with a 10x microscope objective and an avalanche photodiode detector. The working distance to the target was about 7 mm. Scanning was achieved by moving the sample with a stepper motor. Figure 2a shows two measurements on a milled aluminum sample. On the sample there were milled steps with step heights of 5 μm and 10 μm . The milling groves are clearly resolved. They are reproduced in both measurements. In fig. 2b a measurement of a moving mirror is shown. The target distance variation was 100 μm , unambiguous distance range as well as good linearity are shown.

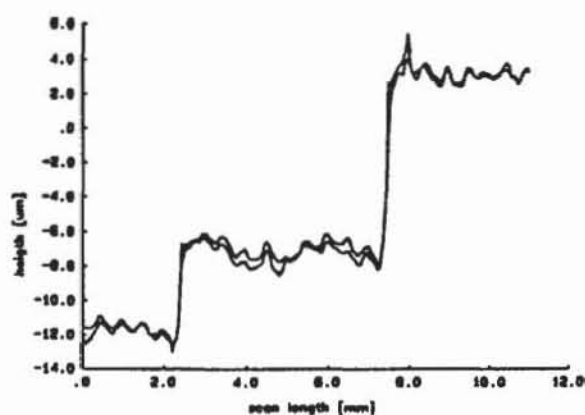
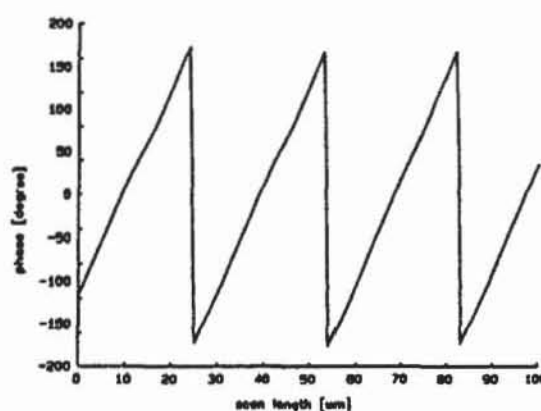

fig. 2a) Line scan over a sample



2b) Profile measurement

4. CONCLUSION

Dual wavelength heterodyne interferometry has proven to be a powerful tool for precision interferometric measurements on optical rough as well as on smooth surfaces. The system acts like a heterodyne interferometer using light with a wavelength of the synthetic wavelength.

5 REFERENCES

1. M. Murty et al., "An Oblique Incidence Interferometer," *Opt. Eng.* 15, 461 (1976)
2. O. Kwon et al., "Rough Surface Interferometry at 10.6 μm " *Appl. Opt.* 19, 1862 (1980)
3. J. C. Wyant, "Testing Aspherics Using Two-Wavelength Holography," *Appl. Opt.* 10, 2113 (1971)
4. F. M. Küchel, and H. J. Tiziani, "Real-Time Contour Holography Using BSO Crystals," *Opt. Commun.* 38, 17 (1981)
5. A.F. Fercher et al., "Rough Surface Interferometry with a Two-Wavelength Heterodyne Speckle Interferometer," *Appl. Opt.* 24, 2181 (1985)
6. R. Dändliker et al., "Two-Wavelength Laser Interferometry Using Super-Heterodyne Detection", 14th Congr. Int. Commission for Optics, Quebec, August 1987 paper B1.2 (SPIE Vol. 813)