

**Focus and Ellipsis:
A Generative Analysis of Pseudogapping
and other Elliptical Structures**

Von der philosophisch-historischen Fakultät der Universität Stuttgart
zur Erlangung der Würde eines Doktors der Philosophie (Dr. phil.)
genehmigte Abhandlung

Vorgelegt von
Kirsten Gengel
aus Balingen

Tag der mündlichen Prüfung: 12. Oktober 2007

Hauptberichterin: Prof. Dr. Artemis Alexiadou
Mitberichter: Prof. Howard Lasnik PhD

Institut für Linguistik/Anglistik der Universität Stuttgart

2007

Table of Contents

Acknowledgements	6
Versicherung/Confirmation	9
Abstract	10
1. Introduction	14
1.1. The Data	14
1.2. Ellipsis in Generative Syntax	17
1.3. Pseudogapping: The Puzzle	19
1.4. Aims and Overview of the Dissertation	23
2. An Overview of the Data	29
2.1. Elliptical Structures in English	29
2.1.1. VP Ellipsis	29
2.1.2. Pseudogapping	30
2.1.3. Pseudogapping vs. VP Ellipsis	33
2.1.4. Gapping	35
2.1.5. Pseudogapping vs. Gapping	35
2.1.6. Sluicing, Fragment Answers, and Bare Argument Ellipsis	37
2.1.7. NP Ellipsis	38
2.2. Pseudogapping Cross-Linguistically	39
2.2.1. Pseudogapping in Icelandic, Norwegian, and Danish	40
2.2.2. Pseudogapping in Icelandic: Prepositional Remnants	43
2.2.2.1. Pseudogapping in the <i>gefa</i> verb class	43
2.2.2.2. Pseudogapping in the <i>skila/ræna</i> verb class	47
2.2.3. Pseudogapping in Portuguese	49
2.2.4. Pseudogapping in French	50

3. Previous Accounts of Pseudogapping	52
3.1. Pseudogapping as an instance of VP Ellipsis	52
3.1.1. A-Movement Analysis: Overt Object Shift	53
3.1.2. A-bar-Movement Analyses	56
3.1.2.1. Heavy NP Shift	56
3.1.2.2. Focus Movement	61
3.1.3. Hybrid Analyses	62
3.1.3.1. Dutch Scrambling	63
3.1.3.2. The Eclectic Approach	65
3.2. Pseudogapping as an instance of Gapping	68
3.2.1. Across-the-Board-Movement	69
3.2.2. Sideways Movement	70
3.3. The Cyclic Linearization Approach	72
3.4. Conclusion	74
4. EPP-driven Movement in Pseudogapping	75
4.1. EPP-driven Object Shift	75
4.2. The Optionality of the EPP for Objects	79
4.3. The Pseudogapping Derivation	82
4.4. Problems for the Object Shift Account of Pseudogapping	84
4.4.1. Scandinavian Object Shift and Object Shift in English	84
4.4.2. Structural Issues	90
4.4.3. The EPP for Objects is not uniform	96
4.5. Additional Evidence against Object Shift: Scandinavian Pseudogapping	97
4.6. Conclusion	102
5. Binding Effects and A-bar-Movement in Pseudogapping	103
5.1. Binding Relations between remnants in Pseudogapping	103
5.2. Reconstruction Effects	109
5.3. Parasitic Gap Licensing in Pseudogapping	111
5.4. Control in Pseudogapping	116
5.5. Binding Relations and A-bar-Movement	117
5.6. Pseudogapping Remnants derived via A-bar-Movement	119
5.6.1. Deriving direct object remnants in double object constructions	120

5.6.2. Deriving indirect object remnant PPs in dative constructions	121
5.6.3. Deriving Pseudogapping with multiple remnants in double object constructions	123
5.6.4. Deriving Pseudogapping with multiple remnants in dative constructions	124
5.7. Conclusion	126
6. Syntactic Focus Movement	127
6.1. The Role of Focus in A-Movement Accounts	128
6.2. Rightward A-bar-Movement: Heavy NP Shift	129
6.2.1. The Distribution of Heavy NP Shift and Pseudogapping remnants	129
6.2.2. Heavy NP Shift in the Hybrid Account of Pseudogapping	132
6.3. Syntactic Focus Movement from a Cross-linguistic Perspective	138
6.3.1. Hebrew	138
6.3.2. Italian	139
6.3.3. Hungarian	140
6.3.4. Malayalam	142
6.3.5. Syntactic Focus Movement in English	144
6.4. Syntactic Focus Movement in Korean Pseudogapping	146
6.5. Syntactic Focus Movement in English Pseudogapping	150
6.5.1. Prosodic Prominence in Ellipsis Constructions	151
6.5.2. Focus Effects in Pseudogapping: A Criticism of the Hybrid Approach	153
6.6. The Syntactic Derivation of English Pseudogapping	156
6.6.1. The Landing Site of Syntactic Focus Movement	156
6.6.2. Deriving direct object remnants and PPs in Pseudogapping	160
6.6.3. Deriving indirect object remnants in Pseudogapping	161
6.7. Exhaustivity and Contrast in Hungarian and English Focus Movement	165
6.7.1. Exhaustivity in Ellipsis Configurations	166
6.7.2. The Non-Identity (Contrastiveness) Requirement	167
6.7.3. Implementing Contrast: The Contrastivity Feature	167
6.8. Conclusion	168
7. The Semantics of Focus and Ellipsis	169
7.1. Focus on the Remnant: The Alternative Semantics Approach	169
7.1.1. The ~ Operator	171
7.1.2. The Focus Structure in Pseudogapping	173

7.2. The Treatment of Alternatives	174
7.2.1. The Ellipsis Problem (Kratzer 1991)	174
7.2.2. Indices and Alternatives in Ellipsis Structures	177
7.2.3. F-Marking and F-Indexing in Syntax	179
7.3. Licensing Deletion	183
7.3.1. Deaccenting and Deletion	183
7.3.2. The Isomorphism Condition	184
7.4. The Revised Focus Condition	191
7.4.1. Rooth's Analysis (Rooth 1992 a, b)	191
7.4.2. Schwarzschild's Analysis (Schwarzschild 1999)	194
7.4.3. E-Givenness (Merchant 2001)	196
7.4.4. E-Givenness and Contrast	200
7.5. Problems for the Revised Focus Condition	202
7.5.1. E-Givenness and Argument Alternations	203
7.5.2. E-Givenness and F-Marking	206
7.5.3. Reconsidering E-Givenness	208
7.5.4. Rephrasing the E-Givenness Condition	210
7.6. Conclusion	211
8. The Deletion Process	212
8.1. The Definition of the E-Feature	213
8.1.1. Features licensing Ellipsis	213
8.1.2. The Semantics of the E-Feature	214
8.1.3. The Phonology of the E-Feature	215
8.2. The E-Feature in different Elliptical Structures	216
8.2.1. The E-Feature in Sluicing	216
8.2.2. The E-Feature in Fragments	218
8.2.3. The E-Feature in VP Ellipsis	219
8.2.4. The E-Feature in Pseudogapping	219
8.3. The E-Feature, E-Feature Raising, and Verb Raising	220
8.3.1. Feature Raising of the E-Feature	220
8.3.2. The E-Feature and Verb Raising	221
8.4. The E-Feature and Focus	226
8.5. The E-Feature and the ~ Operator	228

8.6. The Size of the Elided Phrase	230
8.6.1. Phase-Based Deletion at the ν P Level	230
8.6.2. Phase-Based Deletion at the CP Level	236
8.7. Auxiliaries and Deletion	236
8.7.1. Multiple Auxiliaries in VP Ellipsis	237
8.7.2. Structural Problems	238
8.7.3. The Principle of <i>MaxElide</i>	239
8.7.4. <i>MaxElide</i> in Pseudogapping	240
8.7.5. MaxElide and Deaccenting	242
8.8. Repair by Deletion	243
8.9. Conclusion	245
9. Movement and Deletion: A Uniform Account of Ellipsis	247
9.1. Pseudogapping	247
9.2. VP Ellipsis	248
9.3. Voice Alternations in Ellipsis	249
9.3.1. VP and ν P as Targets of Deletion in Ellipsis and Pseudogapping	251
9.3.2. ν P (and not VP) as Target of Deletion in VP Ellipsis (Johnson 2004)	254
9.4. Sluicing and Fragment Answers	258
9.5. Island Effects in Ellipsis	262
9.6. Gapping	271
9.7. NP Ellipsis	282
9.7.1. A Focus Projection in DP	283
9.7.2. Phase-Based Deletion in the DP	285
9.8. Conclusion	286
10. Conclusion	287
References	291
Appendix: German Abstract	302

Acknowledgements

A few years back, shortly before I began my dissertation project, a former flatmate of mine, a non-linguist, tried to explain to somebody else what I was doing: “She is looking for something that is not there – and I think she found it!” This very much summarises what writing a dissertation on ellipsis, notably on Pseudogapping, sometimes felt like: investigating a construction that proved highly elusive when confronted with the standard tools of generative grammar and minimalism. In the end, I opted for a compromise, which consisted of giving Pseudogapping its own, proper derivation that it seemed to claim, a strategy that is in the tradition of many researchers before me. But at the same time, I aimed at making this special process as general as possible, so as to make it account for other instances of ellipsis as well. The result of this enterprise is presented in this dissertation.

This result, that is, this dissertation, would never have been possible if it had not been for a number of people, to which I now acknowledge my debts, which are numerous, and huge.

First and foremost, I wish to thank my supervisor, Artemis Alexiadou, for all her support, theoretical, and moral, over the last three years. I don’t know for the life of me how she managed to maintain some ‘control’ (in a good sense!) of my quicksilver mind, to keep me on track to make this dissertation possible, and as I hope, a good one. If it had not been for her support in times that were a bit rough, and her invaluable theoretical feedback throughout, this dissertation would never have been feasible. I was fortunate to have a supervisor who not only has an extremely profound understanding of theoretical matters in linguistics, as far as I can judge, but also has the gift of presenting problems that arise in a crystal clear way. Undoubtedly, whatever depth of reasoning and understanding I have achieved in the course of this dissertation is largely due to her teaching. Thus, she deserves and has my undying gratitude for supporting my dissertation project, and, also, beyond the dissertation, for keeping me in Stuttgart, and for being willing to work with me on a project for the next few years.

My second supervisor, Howard Lasnik, naturally also deserves a very special thanks. I am especially grateful to him for agreeing to supervise my work, as he is and has been the single-most influential author on Pseudogapping, and on countless other topics about ellipsis and syntactic theory. It is thus a great honour for me that he is supervising this thesis, and I wish to thank him for extremely valuable discussions all along, for coming to Stuttgart, and for always making time for me when we met at conferences all over the world. His feedback on the theoretical aspects of Pseudogapping was beyond precious, and I hope to have done justice to his suggestions on how to improve my own theory.

I have thus been very privileged in having two excellent supervisors who both inspire me with their ways of approaching and solving linguistic problems. While working and discussing with them, I have learned incredibly much – and I learned from the best.

Thanking the next group of people that I wish to mention here proves quite difficult, since I have had the opportunity of meeting so many great linguists and colleagues that I am bound to forget someone or two in what follows. My apologies beforehand to those I should have mentioned, and did not – to put it linguistically, I am a very unintentional causer (albeit an agent) in this respect.

Parts of the material that is included in this dissertation have been presented at the following conferences: the LingO conference in Oxford, England, the Ellipsis Colloquium in St. Etienne, France, the ConSOLE XIV conference in Vitoria-Gasteiz, the Linguistic Evidence Conference in Tübingen, the Conference on Anaphors in Tunis, the CamLing Conference in Cambridge, England, the Penn Linguistics Colloquium in Philadelphia, the Colloquium on Generative Grammar in Madrid, the Edges Conference in Cyprus, the Workshop on Ellipsis in Stuttgart, NELS 37 in Urbana-Champaign, and the Workshop on DP-Internal Structure in Utrecht. I wish to thank the audiences at these conferences for very helpful feedback and questions, which have greatly contributed to improve my analysis.

In Stuttgart, I have been fortunate to meet with a great number of linguists, among whose the ‘ellipsis’ people come to mind first, notably Jason Merchant, Kyle Johnson, Chris Kennedy in reverse chronological order. Winnie Lechner was a constant source of information regarding all questions about ellipsis. Other people who I have met on the occasion of the talks given in the Guest Lecture Series, or at conferences and elsewhere, and who kindly agreed to meet me and answer my numerous questions, include Elena Anagnostopoulou, Judy Bernstein, Sandy

Chung, Edit Doron, Hans-Bernhard Drubig (who, with Susanne Winkler, deserves special thanks for introducing me to syntax and to the topic of this dissertation), Regine Eckardt, Martin Everaert, Remus Gergel, Jane Grimshaw, Liliane Haegeman, Anders Holmberg, Richard Larson, Maribel Romero, Roger Schwarzschild, Tamina Stephenson, Michael Wagner, Susanne Winkler (thanks for the support and encouragement at the end of my studies and the first year of my dissertation), Karen Zagona, and pretty much all the native speakers of Icelandic, Norwegian or Danish who happened to come near me. Thank you all very much.

In 2005, I had the opportunity to participate in the LSA Summer School at MIT and Harvard, and I wish to express my heartfelt thanks to the professors and other linguists who discussed my emerging theories with me: Cedric Boeckx, Lisa Cheng, Danny Fox, Irene Heim, Norbert Hornstein, Sabine Iatridou, Pauline Jacobson, Richard Kayne, Beth Levin, Yen-hui Audrey Li, Alec Marantz, Jim McCloskey, Shigeru Miyagawa, David Pesetsky, Norvin Richards, and Lisa Selkirk.

A last group of linguists that deserve my thanks are those people who made the stay at various conferences a worthwhile experience, linguistically and non-linguistically: Anna Asbury, Jutta M. Hartmann, Judith Kainhofer, Ida Larsson, Aniko Lipták, Louise Maxwell Llomas, Anna McNay, Martin Salzmann, Beate Starke, Jeroen van Craenenbroeck, Marjo van Koppen, Luis Vicente, Brendan Wolfe, and Nick Zair, among many others.

Finally, on a personal level, I wish to thank the people who have suffered me for the last three years, some on an almost daily basis – Silke Fischer, Florian Schäfer, Nadine Aldinger, Susanne Lohrmann, Sabine Mohr, Tom McFadden, Susann Fischer, Matthias Jilka, Björn Rothstein, Jutta Eichholz, Enyd Michel. Last but not least, I thank the people who have kept me comparatively sane in the linguistics world, Britta Sauereisen, Christine Lauenstein, and Anna McNay, Ellen Gänger, and Monika Louvard, who shared my linguistic and non-linguistic troubles with me. My mentor, Ingrid Hotz-Davies, deserves special thanks for her encouragement and practical advice over the last years. To my friends from Tübingen I owe a great deal of perspective, and I thank them for being patient with me when I disappeared off into one Pseudogap or another – Inka Albrecht, Tina Armbrust, Gudrun Frey, Steffi Gaiser, Miriam Greiner, Christiane Labitzke, Michael Mehl, Bettina Römer, Stephi Schönhof, and Juliane Simon. Thanks also to the people from IBC who lived through the final stages with

me – Kevin, Joy, Sandra, Felice, Petra, and Achim – and who reminded me, together with the Tübingen crowd, that life consists of more than work. My final thanks is due to my family, who, over the last years, constantly supported me in my choice of career.

This dissertation was funded by the *Deutsche Forschungsgemeinschaft* (GRK 609/2 “Linguistic Representations and their Interpretation” and SFB 732 “Incremental Specification in Context”).

Versicherung/Confirmation

Ich versichere, dass ich diese schriftliche Arbeit selbständig und nur mit den angegebenen Hilfsmitteln angefertigt habe, und dass ich alle Stellen, die dem Wortlaut oder dem Sinn nach anderen Werken entnommen sind, durch Angabe der Quellen als Entlehnung kenntlich gemacht habe.

I hereby confirm that I have written this dissertation independently, using only the materials I indicated, and that I have marked those passages that are taken from other works, either as quote or paraphrase, accordingly.

Stuttgart, den 11. Juni 2007

Abstract

In this dissertation I put forward a uniform account of various instances of elliptical constructions in English. The main focus of my analysis will be the Pseudogapping phenomenon, which is illustrated in (1) below.

(1) This should make you laugh – it did me!

The Pseudogapping construction is closely related to two other elliptical constructions in the verb phrase domain, notably VP Ellipsis (in (2), from Lobeck 1995) and Gapping (in (3)).

(2) Mary met Bill at Berkeley and Sue did too.

(3) Claire read a book, and Heather a magazine.

Given the similarities between these three constructions, Pseudogapping has often been considered to be an instance of Gapping, as it involves an element following the elided material. I will reject this analysis, however, as I believe the evidence for the other type of account, which treats Pseudogapping as an instance of VP Ellipsis, is actually stronger.

Adopting a VP Ellipsis-type account such as the one proposed in Lasnik (1995a, and subsequent work) entails one of the central questions that I will pursue in this dissertation: if Pseudogapping is VP Ellipsis, then the remaining element, such as *me* in (1) above, needs to move out of the VP before the VP is subsequently deleted. I will discuss a number of approaches that have assumed various types of movement, for instance, Heavy NP Shift, Object Shift, Dutch Scrambling, Focus movement, or a combination of movements, of Heavy NP Shift and object shift in Takahashi's (2003a) hybrid account. I will show that the most universal movement of the choice provided above is the focus movement type, which is considered to be leftward A-bar-movement. I will thus adopt and further motivate this approach, which has its roots in Jayaseelan's (2001) analysis, since it not only accounts for

the distribution of remnants that occur in Pseudogapping, but also for their focal properties, a dimension that has been rather neglected in the predominant approaches (it is only explicitly implemented in Jayaseelan's 2001 focus movement approach).

Moreover, a further reason to adopt the focus movement approach to Pseudogapping lies in its straightforward compatibility with the deletion operation that has been suggested in Merchant (2001) for Sluicing (and has been extended to other types of ellipsis). His E-feature can be implemented such that it interacts with the focus on the remnant, a condition which, although easily derived from Merchant's (2001) approach, has not been made explicit. I will thus attempt to specify the relation between deletion and focus, and will show that the interaction between the two features, that is, the E-feature which specifies a particular portion of the syntactic structure for phonological deletion, and the Focus feature, derives the movement and deletion analysis of Pseudogapping. The focus movement approach to ellipsis can thus be summarised as follows: focus movement only obtains if it is necessary to move contrastive material out of the phrase that is specified for deletion.

With this very general assumption, we cannot only account for Pseudogapping but also for other types of ellipsis as well, such as Sluicing (which I will analyse as involving focus, too), Fragment answers, and, more controversially, Gapping and NP Ellipsis. The relevant Sluicing (4), Fragments (5, from Merchant 2004), and NP Ellipsis (6, from Lobeck 1995) examples are given below.

(4) I should invite someone, but I don't know **who**.

(5) a. Who did she see?

b. **John**.

(6) Although John's friends were late to the rally, **Mary's** arrived on time.

In each of these cases, the boldfaced element moves to a higher position in the structure, driven by focus, and the remainder of the phrase (the complement) can then be deleted. In chapter 9, I will illustrate in detail how this uniform account of ellipsis can be implemented.

Before I show how the syntactic derivation proceeds, I will first take a critical look at previous approaches of Pseudogapping, and will argue that a focus movement account is superior to these approaches in many respects. In particular, I claim that a hybrid approach that employs both leftward (Object Shift) and rightward movement (HNPS) of the remnant, as suggested in Takahashi (2003a, and subsequent work), is not required, since all remnants could equally well be derived via leftward movement. I argue further that the EPP in the Pseudogapping derivation does not constitute the major feature driving movement of the remnant (as argued by Lasnik 1995a and subsequent work), as it cannot account for the information-structural peculiarities of Pseudogapping. Since these specific properties of Pseudogapping are not applicable to the other cases the EPP is presumed to cover, I conclude that the EPP needs to be coupled with an additional requirement to derive the Pseudogapping structure. This requirement, I argue, is best captured with the concept of contrast. Rather than combining the EPP feature with a contrast feature, I suggest that - depending on the exact syntactic configuration that is assumed for the vP layer (especially in terms of phases) - the EPP requirement which moves the remnant to a specifier position can be replaced with a focus feature that accounts for the movement of the remnant in Pseudogapping.

In the attempt to unify several instances of elided structures, a further issue needs to be borne in mind, especially in the view of recent work on voice alternations in ellipsis. In Merchant's (2007) analysis, Pseudogapping is conceived to involve vP deletion, as it does not allow voice alternations, and VP Ellipsis is regarded as traditional VP deletion, as it permits voice changes between the antecedent and the elided clause. As this matter is far from settled yet, however, given that the judgements of the data are quite subtle, I will argue that, for the time being, Pseudogapping and VP Ellipsis should be regarded to both involve VP deletion, the only difference being that the Pseudogapping remnant needs to vacate the VP prior to ellipsis.

In a similar vein, Sluicing, Fragment answers, and Gapping can also be shown to involve movement out of phrases that are specified for deletion. Crucially, in these instances, it is the TP that is targeted for deletion, an observation that I exploit in the translation of the ellipsis process in English into a phase-based framework.

It seems that the phase theory, which is built on the vP phase and the CP phase (though I will show a potential extension to the DP in chapter 9), with its Spell-out mechanism, is amenable to an account of ellipsis that makes use of specific Spell-out domains. More specifically, I

argue that Pseudogapping and VP Ellipsis involve the deletion of the domain of the vP phase, thus being an instance of non-Spell-out. Similarly, the Spell-out of the TP, which is considered to be the domain of the CP in Chomsky's (2001, 2005) analysis, is prohibited in elliptical constructions that target the higher part of the clause, notably, Sluicing, Fragments, and Gapping. Finally, I show that if the DP were conceived to be a phase as well, the relevant domain would fail to spell-out in NP Ellipsis.

In sum, the mechanism I developed to account for the Pseudogapping construction provides a novel approach to the derivation of ellipsis in general, and has the potential of unifying several, if not all elliptical phenomena, in English grammar. Moreover, due to its generality, it leaves sufficient room to accommodate languages other than English as well. Scandinavian Pseudogapping, for instance, hitherto unattested in the literature, could also receive an account in terms of A-bar-movement (crucially, not object shift), which is predictable on the basis of my analysis.

Thus, an approach to ellipsis which is based on the interaction between focus and deletion as the main concepts (as opposed to the licensing condition approach in Lobeck 1995), and which incorporates the language-specific licensing properties by means of the feature that is responsible for deletion, permits us to cover a greater range of elliptical constructions than was previously possible.

1. Introduction

In this dissertation, I will present a novel approach to the derivation of elliptical structures, which was developed independently of Jayaseelan's (2001) focus movement analysis of Pseudogapping, but ultimately adopts his major arguments and provides an extension of his theory to other types of ellipsis. On the basis of the phenomenon of Pseudogapping, I propose that ellipsis is sensitive to focus in general, and that a variety of elliptical constructions, for instance, VP Ellipsis, Pseudogapping, Gapping, Sluicing, Fragment answers, and NP Ellipsis may receive a uniform account, which employs focus movement of contrastive material out of the part of the structure that is specified for deletion. This focus requirement applies to the remnants of ellipsis, that is, to the remnants in Pseudogapping, Gapping, Sluicing, and Fragment answers. For VP Ellipsis (and, potentially, NP Ellipsis) no actual focus movement of remnants needs to be assumed, but the deletion of material in these cases matches the deletion operation that I propose derives the other types of ellipsis. On the empirical side, I will present novel data from the Pseudogapping phenomenon, which, in its original conception, has hitherto only been attested for English. I will show that in the Scandinavian languages, notably, Icelandic, Danish, and Norwegian, the Pseudogapping phenomenon also occurs, and that in Portuguese, and to a very limited extent, in French, Pseudogapping may also occur.

In the introduction that follows, I will outline the main puzzles that arise very generally in any account of ellipsis in generative syntax and minimalism, and give a very brief data overview of the ellipsis types that will figure in the discussion. I then proceed to present the challenges that Pseudogapping represents in this respect, and will conclude with an overview of the main claims and results of this dissertation.

1.1. The Data

In (1) to (7) below, I provide examples of various instances of ellipsis in English that I will consider in the course of this dissertation. The overview here is intended to give a very brief overview of the phenomena in question, and to illustrate one or two characteristic features of each phenomenon, in order to familiarise the reader with the empirical coverage of the theoretical account in the following chapters. Thus, to lay the grounds for a general discussion of ellipsis, and subsequently, the more specific treatment of Pseudogapping and ellipsis in the VP domain, the data set given here includes VP Ellipsis (1), Pseudogapping ((2) and (3)), Gapping ((4) and (5)), Stripping (6), Sluicing (7), and NP Ellipsis (8).¹

VP Ellipsis

- (1) a. Mary met Bill at Berkeley and Sue did too.
b. Charlie thinks that Mary met Bill at Berkeley, but Sarah knows that Sue didn't.

Pseudogapping

- (2) Speaker A: Drinks like that knock me over.

Speaker B: They would me.

- (3) He asked curiously, 'Which of all those sculptures in the book was the hardest for you to make?' 'The most difficult was the gypsy's crystal ball.'

It surprised him, as it did most people.

Gapping

- (4) Mary met Bill at Berkeley and Sue at Harvard.

- (5) Claire read a book, and Heather a magazine.

¹ The examples are taken from Lobeck 1995, except for the examples in (2) (from Levin 1978), (3) (Dick Francis, *Shattered*) and (5).

Stripping

- (6) a. Jane gave presents to John, but not to Geoff.
b. Jane loves to study rocks, and John too.

Sluicing

- (7) We want to invite someone, but we don't know who.

NP Ellipsis

- (8) Although John's friends were late to the rally, Mary's arrived on time.

Traditionally, ellipsis is conceived to consist of two separate processes, (i) the deletion process, and (ii) the process of recovering the elided material ('licensing' and 'identification' in Lobeck's (1995) terms, for instance). In the VP Ellipsis examples in (1), for example, the portion that is missing from the sentence is the VP, whose contents are easily recovered to mean that *Sue met Bill at Berkeley* in (1a) and (1b).

While VP Ellipsis is very common in English, Pseudogapping, as in (2) and (3), occurs less often, since the Gapping construction, illustrated in (4) and (5), seems to be preferred if speakers wish to establish a contrast between the two parts of the sentence. The Gapping and Pseudogapping construction thus appear to combine deletion with some kind of contrast. Again, the elided material is reconstructed straightforwardly: in (2), Speaker B attests that *drinks like that* would knock her over, too, and in (3), the second conjunct indicates that most people were surprised at the fact that the crystal ball was the most difficult to make. In Gapping, on the other hand, it seems that there too the verb needs to be recovered from the antecedent, with (4) implying that *Sue met Bill at Harvard*, and in (5), that *Heather read a magazine*.

The Stripping (or Bare Argument Ellipsis) examples in (6), in turn, show that almost any amount of redundant material can be left out of the structure (as the name given to this construction already suggests). Consequently, the second conjunct in (6a) yields the interpretation that Jane did not give presents to Geoff, and the second conjunct in (6b)

expresses that John also loves to study rocks. In Sluicing, another widely attested ellipsis structure, the entire tense phrase seems to be elided, leaving only a *wh*-element behind, as shown in (7) below. The NP Ellipsis example given in (8), finally, illustrates an elliptical structure where it is not the VP level or the clausal level that figures as a target for deletion, but the DP level.

From this sample of elliptical structures (see chapter 2 for a more detailed overview of the data), we can conclude the following. Firstly, it seems that ellipsis is able to target different parts of the structure, which results in a variety of distinct elliptical constructions. Secondly, as mentioned above, it seems that ellipsis occurs in constructions which exhibit a certain amount of contrast, seen most clearly in the Gapping and Pseudogapping examples.

Indeed, there seems to be a connection between deletion itself and the fact that it occurs in structures that exhibit a clear contrast structure. It is the relation between these two, that is, the link between focus and ellipsis, that I will investigate in this dissertation. Before I address this particular issue, however, some remarks on the treatment of ellipsis in the generative framework are in order.

1.2. Ellipsis in Generative Syntax

The topic of ellipsis represents one of the great puzzles in the theory of grammar, since the generation of phonologically null material or the deletion of existing material proves to be an intricate process.

On the surface, elliptical structures seem to be an economy device: a speaker does not utter material that she feels sure is already understood in the context, and thus accessible to the hearer. In the syntactic derivation, however, all considerations of economy seem to fail, as the restrictions that hold in the distribution of elliptical structures language-internally and cross-linguistically demand a highly sophisticated approach. This approach, indeed, must not only accommodate the structural differences that obtain in the variety of ellipsis configurations, by means of specifying distinct licensing environments for deletion, but also ensure that ellipsis targets only material that is specified as semantically redundant. At first sight, the latter point seems straightforward, since ellipsis seems to only target redundant material by its very

definition. However, the ellipsis process as such clearly has an optional flavour to it, since the material that can be elided can, in most instances, also be pronounced, or deaccented. Moreover, this points to the fact that redundancy seems to be a relative rather than an absolute concept, since sometimes, as in the contrast between Gapping and Pseudogapping, some parts of the structure survive the deletion, despite their being redundant.

In the literature based on the framework of generative grammar, ellipsis has received different explanations as to where the ellipsis process as such takes place. The analyses put forward roughly fall into two categories, which I will briefly illustrate below (see, for instance, Winkler and Schwabe 2003 for an extensive overview).

The first group of theories has as its common denominator that ellipsis involves a base-generated empty element, the content of which is then filled in at the LF level, with material recovered from the antecedent. Among the main proponents of this LF-copy theory are, for instance, Williams 1977, Fiengo and May 1994, and, adopting a *pro*-form reconstruction theory, Lobeck 1995, 1999). In their respective approaches, no syntactic structure needs to be assumed within the ellipsis site.

As there is evidence, however, that the ellipsis site does, in fact, contain syntactic structure (cf. Kennedy 2003 for an extensive discussion of evidence in support of this claim), a second group of analyses re-emerged (being the standard account of ellipsis in the 1970s), which are based on the assumption that the derivation of material that becomes subsequently elided proceeds, in essence, like a regular derivation in non-elliptical structures. If there is syntactic structure in the ellipsis site, which is mapped straightforwardly onto LF, without requiring a copy process of antecedent material, the ellipsis process, can apply at the PF level, or, in other words, PF-deletion obtains.² This theory has gained much ground in the recent literature on ellipsis, its defendants being, among many others, Chomsky and Lasnik (1993), Lasnik (1995a, and subsequent work), Merchant (2001, and subsequent work), and Tancredi (1992).

From the observation that ellipsis, in part at least, appears to delete structures that would, if spelled out, cause a violation at the interfaces, followed the repair-by-deletion approach, and

² Thanks to Norbert Hornstein for valuable discussion of the respective merits of either approach, and Howard Lasnik for his comments on this issue.

its introduction into the theory (it has found applications in both Lasnik's and Merchant's work, to only name two authors who have implemented it), has equipped the theory of ellipsis with a powerful device: with a repair-by-deletion process as a last resort-type movement, there is actually the possibility of creating violations in the syntactic structure on purpose, so to speak. Given that, in the end, the violations, or, as Lasnik puts it (2005, a.o.), "the offending material" is deleted, there is no overt evidence of a violation. Since, as we will see in what follows, the derivation of elliptical structures may involve a number of operations that might be unaccounted for in non-elliptical contexts, the repair-by-deletion concept is a much cherished device. In the account I put forward in this dissertation, I will adopt the PF-deletion approach, without, however, subscribing to a strict view of the repair-by-deletion strategy.

A final point that needs to be mentioned in this brief overview is the role of information structure in ellipsis, which has received much attention in recent literature. The relationship between ellipsis and focus, though, has been a long-standing reality in the theory, with researchers concerned with focus extending their theories to ellipsis (e.g. Rooth 1992a, b, among many others), and vice versa (e.g. Jayaseelan 2001, again, among many others). A full-fledged version of this relationship between information-structure and ellipsis is found in Winkler (2003/2005), who proposes that the derivation of a sentence proceeds in two cycles, one of which, informally speaking, is concerned with the 'normal' course of the derivation, and the second interacting with the first to establish the appropriate information-structural configuration. In my own theory, I seek to implement the information-structural dimension in ellipsis with a feature, a Focus feature, which then interacts with a second feature, the E-feature (adapted from Merchant 2001), to derive ellipsis.

In the next section, I introduce the main topic of this dissertation, the derivation of Pseudogapping in English grammar.

1.3. Pseudogapping: The Puzzle

Of the data presented in section 1.1. above I will be mostly concerned with what I believe to be the most curious instance of ellipsis, namely, Pseudogapping (illustrated with the examples in (9) to (13) below, all examples taken from Levin (1986)).

Pseudogapping is curious first of all in the sense that it suffers from a slight acceptability problem: while it is perfectly grammatical in comparative structures, many people find it difficult to accept in a non-comparative, that is, a coordinate, or even worse, subordinate structure. The acceptance of Pseudogapping in comparatives might be explained straightforwardly with the hypothesis suggested in Levin (1978, 1986) that Pseudogapping is better in comparatives because the superficially related construction, Gapping, is highly marginal in comparatives.³ Gapping, in turn, as indicated in section 1.1., is readily accepted in coordinate structures by all speakers.⁴

(9) Does that make you mad? It would me!

(10) I'm not citing their analysis so much as I am their data.

(11) I'm sure I would like him to eat fruit more than I would cookies.

(12) I think you need to show yourself more than you do anyone else.

(13) You can't derange, or rearrange, your poems again. (But the sparrows can their song.)⁵

While it is hard to capture the marginality of Pseudogapping in coordinate structures, this is not the only controversial issue about Pseudogapping, since, with regard to the structure, it seems to be a hybrid construction, which combines both properties of VP Ellipsis (given in (14)), and Gapping (in (16)). The Pseudogapping example, as can be seen in (15), has a finite auxiliary like VP Ellipsis, and a contrastive remnant like Gapping.

(14) John invited Sarah, but Mary didn't. *VP Ellipsis*

(15) John invited Sarah, and Mary will _ Jane. *Pseudogapping*

³ I have not been able to test this claim with a large number of speakers. The small group of people I interviewed, however, seemed to agree that Gapping is very odd in comparatives, if not ungrammatical.

⁴ In fact, this generalisation is much stronger: Gapping seems only possible in coordinate structures, and is impossible in virtually all situations where Pseudogapping is acceptable (Howard Lasnik, p.c.).

⁵ Levin (1986: 36, her (4), from 'North Haven (In Memoriam: Robert Lowell)', *New Yorker*, p. 40, Dec. 11, 1978).

(16) John invited Sarah, and Mary _ Jane.

Gapping

Given the hybrid nature of Pseudogapping, it comes as no surprise that its status with respect to the other two elliptical structures is a matter of debate.

Capitalising on the roughly similar distribution of Gapping and Pseudogapping, and the contrastiveness of the remnant, there are researchers (for instance, Zoerner and Agbayani (2000), Agbayani and Zoerner (2004), Johnson (2005, 2006)) who regard Pseudogapping as being related to the Gapping construction.

On the other hand, in view of the auxiliary that seems to license both VP Ellipsis and Pseudogapping, and the fact that Pseudogapping is overall less restricted in its distribution than Gapping, a number of researchers have claimed that Pseudogapping should be derived as VP Ellipsis, with the remnant having moved out of the VP prior to deletion (Jayaseelan 1990, Lasnik 1995a, a.o.). In this dissertation, I will adopt the latter view, but will discuss issues related to Gapping where appropriate.

If one adopts the view that Pseudogapping is a particular instance of VP Ellipsis, the issue arises of how the movement of the contrastive remnant is achieved. In chapter 3, I will consider some of the analyses that have been put forward for this peculiar movement in more detail, and will thus only point out the main assumptions that have been made in the literature. Again, there is no clear consensus provided in these theories, and the derivation of Pseudogapping (in terms of VP Ellipsis) has been taken to involve one (or more) of the following types of movement.

(i) *Heavy Noun Phrase Shift (HNPS)*.

In this analysis, the remnant, being contrastive, is moved out of the VP via Heavy NP Shift, that is, rightward A-bar-movement. Alternatively, in a recent implementation on the basis of Larson (1988), Johnson (2005) assumes that the same configuration is achieved if in Heavy NP Shift in Pseudogapping, the object does not move, but movement of the verb obtains.

(ii) *Object Shift (OS).*

In contrast to the Heavy NP Shift analysis, the object shift account, as proposed in Lasnik (1995a, and subsequent work) involves A-movement of the remnant out of the VP, with the landing site of the remnant being the specifier of the AgrO projection. The movement of the remnant in this type of analysis is motivated by an EPP feature in AgrO, which triggers movement of the object into its specifier position.

(iii) *Focus Movement.*

Jayaseelan (2001) suggests that the movement in Pseudogapping is driven by a focus feature on the Pseudogapping remnant. The landing site of this leftward movement is either the specifier position of a Focus projection above the vP layer, or, in Chomsky's (2001, 2005) framework, the outer specifier of the vP projection.

From the theories mentioned above we can conclude that an analysis of Pseudogapping in terms of movement of the remnant out of the VP can thus be implemented with either A-movement or A-bar-movement. Each of the movements proposed, with the exception of the first one, however, require additional qualifications as to why they should occur in English Pseudogapping, if they are not to be found elsewhere in the grammar of English. Moreover, as we will see later, the Heavy NP Shift approach, while well attested for English, also encounters problems with the distribution of the Pseudogapping remnants, which does not entirely coincide with the elements that usually undergo Heavy NP Shift.

An issue that is related to the type of object movement is the generality of the object movement. Lasnik (1995a and subsequent work) seeks to establish a universal overt object movement process in English, building on proposals of Johnson (1991) and Koizumi (1995). In the first chapters of this dissertation, I will take a closer look at the arguments he provides for this claim, and conclude that it is not A-movement but rather A-bar-movement that is responsible for the movement in Pseudogapping. This conclusion, while it does not affect the validity of the object shift operation as a whole, attributes a different status to Pseudogapping, making it distinct from other constructions that may employ object shift, such as ECM constructions and particle shift, rather than unifying the status of objects in Pseudogapping with the general behaviour of objects in English. As part of this discussion is founded on the

theory of features developed in the late 1990s, I will take care to outline the respective assumptions that influenced Lasnik's (1995a) and related analyses.

It seems, then, on the whole, that the movement in English Pseudogapping has a very special character, and a major part of this dissertation is devoted to

- (i) a comparison of the aforementioned approaches, and, on the basis of these,
- (ii) the development of an analysis of movement that can explain a large number of the properties, if not all, that are associated with the remnant in Pseudogapping.

Apart from the question of which movement may be involved in the movement of the remnant in Pseudogapping, there are further puzzling issues connected to Pseudogapping derivation, which are most clearly exposed in Lasnik's (1995a, 1999a) approach. For instance, a further puzzle arising in Pseudogapping is the question of verb movement. Lasnik's (1995a) account, again, is the first to address the issue of verb raising in Pseudogapping. In his analysis, the verb moves overtly in English, an assumption maintained also in current syntactic theory, and in Pseudogapping (and, possibly, by extension, in VP Ellipsis), the verb fails to raise. The violation that ensues with this lack of verb movement is then remedied by deletion.

While I will reject the precise mechanism that Lasnik (1995a, 1999a) proposes to account for the failure of verb movement in Pseudogapping, I will nonetheless conclude that there is reason to believe that there is indeed no verb movement in VP Ellipsis or Pseudogapping, although I will suggest a different implementation of how this result can be achieved.

On the basis of the above, the questions that are at the core of this dissertation can thus be formulated as in the next section, where I will also give an outline and overview of the organisation and structure of the dissertation.

1.4. Aims and Overview of the Dissertation

The main research questions and the answers I will argue for in this dissertation can be summarised in the following.

With regard to the Pseudogapping configuration, the first question can be captured as in (i) below.

- (i) What is the nature of the movement that is assumed for the Pseudogapping remnant? Is it A-movement, or A-bar-movement, or a combination of both? How can it be implemented in the current syntactic framework?

I will argue that the crucial movement is A-bar-movement, which can accommodate the focus effects we find in Pseudogapping. I will thus adopt, and slightly modify, Jayaseelan's (2001) approach to Pseudogapping as being derived via focus movement. Moreover, I claim that it is precisely the interaction between deletion (analysed via the E-feature in Merchant's (2001) approach) and the focus feature of the remnant that triggers the otherwise illicit movement of the focused elements in question. As we will see below, this new mechanism of movement and deletion allows us to account for other types of elliptical structures as well.

The second question concerns the treatment of the verb in Pseudogapping.

- (ii) What is the status of the verb that is to be deleted in Pseudogapping? Does it raise from V to *v*, as in non-elliptical contexts? If it does not, what blocks this kind of movement?

My take on this question will be that there is good reason to believe that verb raising and verb deletion are actually in a kind of complementary distribution. If the verb does not raise in Pseudogapping (and, possibly, by extension, not in VP Ellipsis), the reason may be found to be lying in the E-feature, which specifies the relevant part of the structure for deletion.

A third question that is directly related to the second is the following.

- (iii) Depending on the raising or non-raising of the verb, the question poses itself of what is the exact 'size' of the structure that is targeted by the deletion. Is it the VP, as previously assumed for both VP Ellipsis and Pseudogapping, or, as recently suggested in Merchant (2007), the entire *v*P? If it is the *v*P, how does the derivation proceed to accommodate the deletion of the entire phase, in a phase-based theory, for instance?

In this dissertation, I will conclude that the voice alternation effects that Merchant adduces for his claim that it is the *vP*, and not the *VP*, that is deleted in Pseudogapping, are less clear than they may seem. Thus, I propose that, pending further evidence on this matter, it is still possible to analyse Pseudogapping as involving *VP* deletion rather than *vP* deletion. The account I propose, which makes use of *VP* deletion, has also the additional advantage that it allows us to capture ellipsis in a phase-based framework of syntactic theory, where ellipsis would target the Spell-out domains of the relevant phases, resulting, as it is, in non-Spell-out.

The theory that I will present for Pseudogapping has the benefit of being easily extensible to cover other instances of ellipsis. If ellipsis is indeed a combination of deletion and prior movement of focused material out of the future ellipsis site, then the question in (iv) can be given an answer.

(iv) If elliptical structures such as Pseudogapping can be explained with focus movement and subsequent deletion, can the focus effects that we find in other ellipsis cases be explained as well with this type of analysis?

As the suggestive nature of this question already indicates, the claim I will defend in this dissertation is that a uniform account of ellipsis is indeed feasible, and is able to cover the basic facts that apply in every instance of ellipsis that I investigate in the course of this dissertation. Moreover, the conclusion that many ellipsis cases can be treated on a par permits also a uniform phase-based account of deletion, since, as we will see, the elliptical configurations that are located at the *CP* (or rather, *TP*) level, can equally be considered to be non-Spell-out of the relevant Spell-out domain, parallel to the scenario that I will assume for the *vP* phase.

The overall organisation of this dissertation roughly corresponds to the order in which I presented the questions in (i) to (iv) above.

In the second chapter, I will present some more data, notably from Pseudogapping.

In chapter 3, I will give an overview of previous accounts that have discussed Pseudogapping, also including analyses that proclaim a similarity of Pseudogapping to Gapping. Arguing that Pseudogapping should be aligned to *VP* Ellipsis, however, I will not

consider the latter type of approach in the remainder of this dissertation, but focus exclusively on the theories of Pseudogapping in terms of VP Ellipsis with prior movement of the remnant out of the VP. Consequently, I will provide a critical discussion of movement in Pseudogapping structures in subsequent chapters of this dissertation.

In chapter 4, I will first discuss object movement in terms of A-movement, more specifically, with respect to the EPP, which is considered to be the trigger for object shift in Lasnik's (1995a, 1999a) analysis of Pseudogapping. I will show, however, that the EPP requirement for objects, as proposed in Lasnik's (1999a, 2001a, a.o.) theory, which covers not only Pseudogapping but also exceptional case-marking (henceforth: ECM) structures, and particle shift, cannot derive the information-structural differences between these phenomena and the Pseudogapping construction.

The fifth chapter therefore investigates the validity of the A-movement approach as such, even if not considered to be object shift in particular. Building on the proposals by Baltin (2000, 2003) and Takahashi (2004a), I show that the Binding effects arising in Pseudogapping can equally be accounted for with an A-bar-movement approach.

In chapter 6, I present the A-bar-movement approach that I will adopt in this dissertation, the syntactic focus movement approach. I show first that a rightward 'focus' movement approach in terms of Heavy NP Shift cannot account for the distribution of the remnants in Pseudogapping, and fails to include all potential remnants. I will provide evidence that focus movement to the landing site I assume for the remnant in Pseudogapping exists in other languages, notably, in Hungarian, and, as proposed in Jayaseelan (2001), also in English for focus movement processes that do not involve ellipsis. I will thus unify the two movements proposed in Takahashi's (2003a, 2003b, 2004a) hybrid approach of Pseudogapping, which involves both object shift and Heavy NP Shift into one movement, focus movement. I conclude chapter 6 with a brief discussion of the requirement that triggers English focus movement as opposed to focus movement in Hungarian, and propose that it is contrastiveness rather than exhaustivity that plays the crucial role in ellipsis configurations in English.

In chapter 7, I will discuss the interaction between focus, implemented as a Focus feature in the syntax, and ellipsis. I will start with an overview of the licensing of focus in the semantics of ellipsis, and later combine it with the requirement of deletion. More specifically, I discuss Rooth's (1992a, b) Alternative Semantics approach, which incorporates the concept of

contrast, and then briefly cover a problem arising in the computation of alternatives for VP Ellipsis, as pointed out in Kratzer (1991). Building on Kratzer's (1991) proposal, I suggest that the alternatives in ellipsis contexts could also be computed using F-marking and F-indices in syntax, thus incorporating the contrastiveness requirement directly rather than implicitly as in the definition of Rooth's (1992a, b) focus operator \sim (the 'squiggle' operator). After an outline of this general idea, I proceed to the licensing of deletion, treating the difference between deaccenting and deletion, and covering the structural isomorphism condition, which is intended to establish syntactically and semantically parallel structures at the LF level. On the basis of this discussion, I then turn to Merchant's (2001) analysis, which maintains that the isomorphism condition should be replaced with a revised focus condition, making use of a bidirectional definition of Givenness (based on Schwarzschild 1999). I show that this patterns with the \sim operator that Rooth (1992a, b) assumed to be also involved in the licensing of ellipsis, and conclude that the revised focus condition, and the E-Givenness condition put forward in Merchant's (2001) analysis can equally be captured in Rooth's (1992a, b) framework. The benefit of the adoption of this approach, which would otherwise be quite similar to Merchant's (2001) own implementation, is that it allows us to 'translate' the mechanism assumed for the \sim operator into two distinct syntactic features: the Focus feature, and the E-feature, adopted from Merchant (2001).

Consequently, in chapter 8, which is concerned with the syntactic implementation of deletion, I show first how this E-feature can be implemented to specify not only the semantic requirements on deletion but also the syntactic locus of ellipsis. My proposal, as we will see, differs from Merchant's (2001) analysis in the following respect. While he accounts for deletion by specifying an element for deletion whose complement must not contain any non-given (i.e., focused) material, I suggest that the function of the E-feature, instead of triggering only deletion of a constituent with given material, is specified such that it can also interact with Focus features on the respective remnants of ellipsis, causing them to move out of the domain of the E-feature. In this sense, the E-feature interacts with focus, and is thus directly related to the \sim operator assumed in Rooth (1992a, b). The remainder of the chapter on deletion is devoted to the question of how big the deletion site actually is, and, as a natural consequence, to the question of what happens to the verb, whether it needs to raise or, on the contrary, must not raise in Pseudogapping (and VP Ellipsis). I then extend the question of the size of the deletion site to cover a curious mismatch between VP Ellipsis, which allows multiple auxiliaries, and Pseudogapping, which becomes seriously degraded once it contains

more than one auxiliary. A brief discussion on the repair-by-deletion strategy concludes the discussion of deletion in chapter 8.

In chapter 9, I will bring together everything that I argued for in the previous chapters, and show that the movement and deletion account cannot only derive Pseudogapping, but can be extended to cover various other instances of ellipsis in English, such as VP Ellipsis, Sluicing, Fragment answers, Gapping, and NP Ellipsis. As this uniform approach is not entirely unproblematic, I will also discuss some of the ramifications that arise with regard to voice alternations and island effects. As a final point, I will briefly illustrate how the elliptical processes may be aligned to fit into a syntactic framework built on phases.

Chapter 10 concludes the discussion, and provides a brief outlook on potential areas of future research.

2. An Overview of the Data

In this chapter, I will provide empirical data of the phenomena that I will discuss in the course of this dissertation. I will be mainly concerned with elliptical structures that occur in the lower part of the clause, notably Pseudogapping, and VP Ellipsis, but will also cover Sluicing, Fragment answers, Gapping, and NP Ellipsis.⁶ The main focus of this dissertation is on English, given that Pseudogapping has hitherto only been attested for English. In the present chapter, however, I will also provide some data from the Scandinavian languages, and one French example and Portuguese example, without attempting an analysis for these in subsequent chapters.⁷

2.1. Elliptical Structures in English

Below, I give an overview of the elliptical structures found in the grammar of English, namely, VP Ellipsis (in 2.1.1.), Pseudogapping (2.1.2.), Gapping (2.1.4.), Sluicing (2.1.6.), Fragment answers (2.1.7.), NP Ellipsis (2.1.8.), and Bare Argument Ellipsis (Stripping; 2.1.9.).

2.1.1. VP Ellipsis

VP Ellipsis in English is characterised by having a finite auxiliary in front of the elided part of the structure. Moreover, it can be constructed backwards, with the ellipsis site in the first part of the sentence, as in (1) (but not always, as illustrated in (4)). VP Ellipsis often is

⁶ I will not treat Right-Node-Raising or Bare Argument Ellipsis, and only note the influence of the particularities of the structure of comparative constructions (as opposed to coordinate structures) where necessary.

⁷ Given the odd character of the French and Portuguese examples, I have not investigated them yet in closer detail, but hope to do so in future research. While I believe that some generalisations are possible with respect to the Scandinavian examples, which I will point out, I will merely add the Romance examples to give a possible direction of which languages might be interesting to look at for further empirical research.

assumed to involve special polarity marking, which is encoded with the emphatic marker *too*, or negation.

(1) Because Pavarotti couldn't [VP e], they asked Domingo to sing the part.
(Lobeck 1995: 20, her (37))

(2) John talked to Bill on Tuesday but Mary didn't [e] until Wednesday.
(Lobeck 1995: 21, her (43))

(3) a. Mary met Bill at Berkeley and Sue did [e] too.

b. Mary met Bill at Berkeley although Sue didn't [e].

c. Charlie thinks that Mary met Bill at Berkeley, but Sarah knows that Sue didn't [e].

(Lobeck 1995: 22, her (45))

(4) a. *Sue didn't [e] but John ate meat.

b. Because Sue didn't [e], John ate meat.

(Lobeck 1995: 22, her (47))

(5) I can't go back to Madison now, but I can \emptyset next week.

(Levin 1978: 235, her (39))

Examples such as (2) and (5), where there is an element that seems to directly follow the ellipsis site, are sometimes assumed to be instances of Pseudogapping rather than VP Ellipsis. The Pseudogapping construction is illustrated in the following section.

2.1.2. Pseudogapping

In this section, I provide a number of Pseudogapping examples, and also point out generalisations concerning its distribution, and its status with respect to VP Ellipsis. As can be seen in example (6), for instance, Pseudogapping characteristically has a finite auxiliary in front of the ellipsis site, and some contrastive material, most often a DP or a PP directly following the ellipsis site. As we will see below, this contrastive remnant makes it resemble to the Gapping construction.

(6) He realized he could make more money in some other position than he can Ø farming.
(Levin 1978: 229, her (3a))

(7) i felt so sorry for this Valentine and decided to send it to you ‘cause i knew you’d make it
feel happy and wanted ... like you did Ø me!
(Levin 1978: 229, her (3b), text on a Valentine’s Day card)

(8) Speaker A: Drinks like that knock me over.
Speaker B: They would Ø me.
(Levin 1978: 230, her (12))

(9) Does that make you mad? It would me!
(Levin 1986: vii)

(10) I’m not citing their analysis so much as I am their data.
(Levin 1986: 12, her (4))

(11) I’m sure I would like him to eat fruit more than I would cookies.
(Levin 1986: 15, her (7))

(12) I think you need to show yourself more than you do anyone else.
(Levin 1986: 16, her (13))

Descriptively speaking, Levin (1978: 229) distinguishes between regular Pseudogapping, causative Pseudogapping, and comparative Pseudogapping.

Causative Pseudogapping typically occurs with nonagentive experiencer causative verbs such as *bother*, *interest*, *scare*, more specifically, *psych verbs* that take an experiencer object such as *annoy*, *embarrass*, *fascinate*, *surprise*, and another group of verbs that can be classified as non-emotive causatives, such as *knock NP out*, *wake/keep NP up*, or *take NP X long to V* (cf. (8) above). In causative Pseudogapping, the remnant is exclusively animate, usually human, and often a personal pronoun that introduces new information (Levin 1978: 229, 231).

Moreover, there is sometimes a generic character present in Pseudogapping, as illustrated in (13) (Levin 1978: 231, her (17)).

(13) Speaker A: Cream rinse makes my hair get oily faster.

Speaker B: It (usually) does Ø mine Ø, too.

Comparative Pseudogapping (with adverbial comparatives) as in (13) above, for instance, and (14) below (Levin 1978: 231, her (21)), is the most widely accepted type of Pseudogapping.

(14) It makes me feel as bad as it does Ø you Ø.

Sometimes, a Pseudogapping configuration is ungrammatical in coordinate structures (as in (15)), but perfectly grammatical in comparative structures (as in (16)) (both examples from Levin 1978: 232, her (22a, b)).

(15) *You probably just feel relieved, but I do Ø jubilant.

(16) I probably feel more jubilant than you do Ø relieved.

Levin suggests that comparative Pseudogapping might be more acceptable because the otherwise preferred construction, Gapping, is not available in comparative structures, as illustrated in (17) (Levin 1978: 232, her (25)).

(17) a. Larry loses as many pens as Harry does Ø pencils.

b. ?* Larry loses as many pens as Harry Ø pencils.

In general, Pseudogapping becomes more acceptable once there is sufficient contrast present in the structure, as Levin (1978: 232) notes. This is obviously true for comparative structures, and, according to Levin (*ibid.*), noncomparative structures improve once there is a different polarity in the antecedent and the second conjunct, and once there is focus stress.

While there are certain classes of verbs favoured in Pseudogapping, there are also other verbs that seem to be categorically ruled out. These verbs include psych perception verbs such as *smell*, *taste*, *sound*, *look*, requiring a stative complement, such as *seem*, *appear*, *turn out*

(Levin 1978: 233). In contrast to these verbs, Pseudogapping with stative verbs requiring an NP complement, such as *own*, *contain*, *constitute*, is more acceptable. The pattern is illustrated in the following examples ((18) and (19), from Levin 1978: 233, her (28) and (30)).⁸

(18) a. ?This bottle might contain sulfuric acid, but it shouldn't Ø copper sulfate.

b. ?? This bottle might contain sulfuric acid, but it doesn't Ø copper sulfate.

(19) Speaker A: These leeks look/smell/taste terrible.

Speaker B: a. * Your steak will Ø better.

b. * The onion rings do Ø even worse.

2.1.3. Pseudogapping vs. VP Ellipsis

Johnson (2003: 15) notes, citing Levin (1986), that there are some differences between VP Ellipsis and Pseudogapping, such as the following, illustrated in (20) (Johnson 2003: 15, his (45), Levin 1986: 53, her (8) and (9)), where VP Ellipsis is possible in the antecedent VP, and Pseudogapping is rather marginal in this respect.

(20) a. Although it doesn't always _ , it sometimes takes a long time to clean the hamster's cage.

b. ??Although it doesn't _ Sally, it takes Karen a long time to clean the hamster's cage.

As Levin (1986) notes, Pseudogapping and VP Ellipsis differ slightly, most obviously with respect to what has later been called the Backwards Anaphora Constraint (cf. Lobeck 1995). Johnson (1996a: 83) gives the examples in (21) (his (25)), to show that VP Ellipsis is licensed in the first conjunct, whereas Pseudogapping is not (an observation already made in Sag 1976).

(21) a. Although Holly doesn't [e], Doc eats rutabagas.

b. *Although Mag doesn't [e] eggplants, Sally eats rutabagas.

⁸ Levin (1978: 233) notes that the auxiliary 'do' is worse than a modal in these structures. Note, however, that the ungrammaticality of the sentences in (19) (her (30)) may stem from a ban on adjectival remnants in general.

Moreover, as Johnson (1996a: 83) and Lasnik (1995a and subsequent papers) point out, Pseudogapping is not able to target only a part of a prepositional phrase, as illustrated in (22) (taken from Johnson 1996a: 83, his (27a)).

(22) *Sally will stand near Mag, but he won't [e] Holly.

There is some counterevidence to this claim, however, as shown in (23) below (Levin 1986: 74, fn. h, her (13)), and taken up in e.g. Lasnik 1999c).

(23) You have to sign onto it [the printer] like you do Ø the terminal.

Further, Pseudogapping is not able to move only a part of a noun phrase, as indicated by the ungrammaticality of the example in (24) below (e.g. Johnson 1996a: 83, his (27b), cf. also Lasnik's discussion of similar data (Lasnik 1999c, a.o.)), an observation originally made by Tomioka (1997).

(24) *While Holly didn't discuss a report about every boy, she did [e] every girl.

In contrast to these examples, VP Ellipsis seems fine in these contexts, as shown in (25) (Johnson 1996a: 84, his (28b-d)). However, as Lasnik points out (p.c.), this is not yet proof that the two phenomena are different in nature – it may well be the case that an additional movement constraint applies in Pseudogapping, giving the difference in acceptability.

(25) a. Sally will stand near every woman that you will [e].

b. I know which woman HOLLY will discuss a report about, but I don't know which woman YOU will [e].

c. Holly discussed a report about every boy that Berman had [e].

Johnson (2001: 463) also notes that Pseudogapping is more restricted with respect to the sloppy reading for pronouns. Consider the contrast between (26a) and (26b) (Johnson 2001: 464, his (87)). In (26b), the only possible interpretation is that Frank had given chocolates not to his own sweetie, but to Frank's sweetie. Johnson (2001: 464) speculates that this difference in interpretation might be due to the special contrast condition holding in Pseudogapping, without being specific as to how this might be implemented.

- (26) a. Fred₁ gave flowers to his₁ sweetie because Frank₂ had _ .
 _ = given flowers to his₂ sweetie.
 _ = given flowers to his₁ sweetie.
- b. Fred₁ gave flowers to his₁ sweetie because Frank₂ had _ chocolates.
 _ ≠ given chocolates to his₂ sweetie.
 _ = given chocolates to his₁ sweetie.

Pseudogapping does not only differ from VP Ellipsis, as illustrated above, it also differs from Gapping in several respects, as shown in the next section.

2.1.4. Gapping

As illustrated in (17) above, Gapping and Pseudogapping superficially very similar (which makes the difference in acceptability in (17) so odd). More specifically, Gapping, as in (27) and (28), for instance, has a contrastive remnant like Pseudogapping, without having the finite auxiliary in front of the ellipsis site.

- (27) Mary met Bill at Berkeley and Sue [e] at Harvard.
 (Lobeck 1994: 21, her (42a))⁹

- (28) Claire read a book, and Heather a magazine.

However, Gapping seems to be more restricted than Pseudogapping, as we will see in the comparison of the two constructions in the next section.

2.1.5. Pseudogapping vs. Gapping

Pseudogapping is not restricted to coordinations to the extent that we find in Gapping. Compare the ungrammatical Gapping examples in (29) with the corresponding grammatical

⁹ Howard Lasnik (p.c.) points out that examples such as (27) are highly controversial in the literature, since they are considered ungrammatical by many speakers, including himself.

Pseudogapping examples in (30) (Johnson 2003: 17, his (47d,e,f) and (48c,d)). Clearly, Pseudogapping tolerates a wider variety of conjunctions.

- (29) a. ?*Vivek likes Chinese action films, but Nishi ~~likes~~ sci-fi movies.
b. *Sam ate something, but Mittie ~~ate~~ nothing.
c. *Some ate natto TODAY, because others ~~ate natto~~ YESTERDAY.

- (30) a. Vivek might like Chinese action films, but Nishi doesn't _ sci-fi movies.
b. Some will eat nattoo TODAY, because others had _ YESTERDAY.

A further constraint is found with respect to embedding in general. Consider the contrast illustrated in (31) (Johnson 2003: 18, his (53)). In (31a), Pseudogapping targets material within the embedded clause, which is not possible in Gapping, as shown in (31b).

- (31) a. Mittie ate nattoo, and I thought that Sam had _ rice.
b. *Mittie ate nattoo, and I thought that Sam ~~ate~~ rice.

Similarly, it is possible for Pseudogapping to have material as antecedent that is embedded in the antecedent clause, which is impossible in Gapping, as illustrated in (32) (Johnson 2003: 18, his (54)).

- (32) a. Either CHUCK thought Mittie had eaten NATTO or LIZ has _ RICE.
b. *Either CHUCK thought Mittie has eaten NATTO or LIZ ~~has eaten~~ RICE.

Another difference between Pseudogapping and Gapping concerns the scope of negation. In Pseudogapping, the negation is restricted to the first clause, in Gapping, however, as shown in (33), the negation scopes over both conjuncts (Johnson 2003: 19, his (57)). This, in fact, can be due to the fact that in Pseudogapping, unlike Gapping, the relevant part of the sentence is not deleted (Howard Lasnik, p.c.).

- (33) Kim didn't play bingo and Sandy ~~didn't~~ sit at home all evening.

Evidently, one must conclude from the comparison of Pseudogapping with VP Ellipsis and Gapping that the three constructions seem to differ to a great extent. In the course of this

dissertation, notably in chapter 9, I will come back to these differences, and show that a unified account of these constructions is nevertheless possible, in the sense that the differences between them fall out, in part at least, from the consequences of the analysis that I propose.

In the remainder of this chapter, I will now turn briefly to the other elliptical constructions in English that not only involve a missing verb but delete a greater part of the structure, namely, Sluicing, Fragments, NP Ellipsis and Bare Argument Ellipsis (Stripping), before I move on to cross-linguistic instantiations of Pseudogapping.

2.1.6. Sluicing, Fragment Answers, and Bare Argument Ellipsis

The Sluicing configuration, made known by Ross (1969), is most commonly treated as IP Deletion. It strands a *wh*-element as remnant, as indicated in (34) to (40) below (example (34) is from Lobeck (1995: 20), her (39); (35) to (40) correspond to Merchant's (2004: 664) example (7)).

(34) We want to invite someone, but we don't know who [e].

(35) Jack bought something, but I don't know what.

(36) A: Someone called.

B: Really? Who?

(37) Beth was there, but you'll never guess who else.

(38) Jack called, but I don't know when/how/why/where from.

(39) Sally's out hunting – guess what!

(40) A car is parked on the lawn – find out whose.

Fragment answers, on the other hand, strand a single constituent as an answer to a previous question, as illustrated in the dialogue in (41) and the ‘implicit’ dialogue in (42) (both from Merchant (2004: 661: his (1) and (2)).

(41) Abby and Ben are at a party. Abby asks Ben about who their mutual friend Beth is bringing as a date by uttering: “Who is Beth bringing?” Ben answers: “Alex.”

(42) Abby and Ben are at a party. Abby sees an unfamiliar man with Beth, a mutual friend of theirs, and turns to Ben with a puzzled look on their face. Ben says: “Some guy she met at the park.”

A related construction is Bare Argument Ellipsis (Stripping) in (43) (Lobeck 1995: 27, her (66)), which also strands one constituent in a verb-free environment, but maintains a property associated with VP Ellipsis, namely, the polarity markers *too* or *not*.¹⁰

- (43) a. Jane gave presents to John, but not [e] to Geoff.
b. Jane loves to study rocks, and [e] geography too.
c. Jane loves to study rocks, and John [e] too.

A last, large complex of elliptical configurations is found in the DP. The so-called NP Ellipsis can have a number of remnants, of which I will only give a few in the next section. As the main topic of this dissertation is the VP domain, I will only consider NP Ellipsis in terms of the unified approach that I will formulate in chapter 9.

2.1.7. NP Ellipsis

NP Ellipsis is widely attested in English, and comes in two variants, so to speak, with and without *one*-insertion. In this dissertation I will concentrate more on the structure without *one*-insertion, that is, on examples such as the ones given in (44) to (47) below. In this instance of ellipsis, the deletion site comprises the material following the possessive element,

¹⁰ As a detailed analysis of Stripping and its relation to VP Ellipsis would lead too far afield from the original topic of my dissertation I will not attempt an analysis of this particular ellipsis phenomenon.

the NP in (44), or an NP introduced by selected quantifiers (45), numerals (46), or demonstratives (47).

(44) Although John's friends were late to the rally, [_{NP} Mary's [e]] arrived on time.
(Lobeck 1995: 20, her (38)).

(45) John called out the children's names, and many/few/all/each/some [e] answered.
(Lobeck 1995: p. 45)

(46) The students attended the play but two [e] went home disappointed.
(Kester 1996: p. 195)

(47) Although she might order these [e], Mary won't buy those books on art history.
(Kester 1996: p. 195)

In the remainder of this chapter, I will return to Pseudogapping, and provide some cross-linguistic data.

2.2. Pseudogapping Cross-Linguistically

As I mentioned in the introduction, Pseudogapping has previously been only attested for English, with the potential exception of Korean Pseudogapping (cf. Kim 1997), which, however, patterns more with English VP Ellipsis. In view of the object shift approach proposed in the literature on Pseudogapping (notably Lasnik 1995a, and subsequent work), the question arises whether Pseudogapping should exist in languages that make regular use of object shift, that is, the Scandinavian languages. As we will see in the next section, this presumption is borne out.

2.2.1. Pseudogapping in Icelandic, Norwegian, and Danish

Instances of Pseudogapping can indeed be found in the Scandinavian languages, as a preliminary survey has shown.¹¹

While Swedish does not allow Pseudogapping, Icelandic as well as two Mainland Scandinavian languages, namely Norwegian and Danish, do have a construction that resembles English Pseudogapping. The examples in (48) and (49) below illustrate Pseudogapping in Norwegian, and (50) and (51) show the Icelandic counterparts (with ‘_’ indicating deleted material).¹²

(48) Prepositional Complements (Norwegian):

- a. Peter kan vente lenger på Mari enn Paul kan _ på Kari.
Peter can wait longer for Mari than Paul can for Kari.
‘Peter can wait longer for Mari than Paul can for Kari.’
- b. Peter vil vente lenger på Mari enn Paul vil _ på Kari.
Peter will wait longer for Mari than Paul will for Kari.
Peter will wait longer for Mari than Paul will for Kari.’
- c. Peter skal lese flere bøker for Mari enn Paul skal _ for Kari.
Peter shall read more books for Mari than Paul shall for Kari.
‘Peter shall read more books for Mari than Paul shall for Kari.’
- d. Per har lest flere bøker for Kari enn Paul har _ for Mari.
Per has read more books for Kari than Paul has for Mari.
‘Per has read more books for Kari than Paul has for Mari.’

¹¹ The Norwegian examples were provided by Jorunn Hetland (p.c.); the Icelandic data goes back to Gunnar Hrafn Hrafnbjargarson (p.c.). Further data that support the empirical judgements above, but are not listed here, were provided by Arne Martinus Lindstad (Norwegian, p.c.), Øystein Nilsen (Norwegian, p.c.), and Torgrim Solstad, Catherine Fabricius-Hansen (Danish, p.c.) and Maria Melchior (Danish, p.c.), Anders Holmberg (Swedish, p.c.) and Ida Larsson (Swedish, p.c.), and Kjartan Ottósson (Icelandic, p.c.), and Nicole Déhé (Icelandic data on the double object construction).

¹² I have omitted the Danish examples here for ease of exposition, since they seem to follow the Norwegian pattern in all relevant respects.

- e. Per vil leke lenger med Mari enn Paul vil _ med Kari.
 Per will(wants to) play longer with Mari than Paul will with Kari.
 ‘Per will play longer with Mari than Paul will with Kari.’

(49) Dative Construction (Norwegian):

- a. *Mary vil gi Susan mange penger og Paul [vil _ Jane en bok].
 Mary will give Susan much money and Paul will Jane a book.
 ‘Mary will give Susan much money, and Paul will Jane a book.’
- b. *Mary vil gi mange penger til Susan og Paul [vil _ en bok til Jane].
 Mary will give much money to Susan and Paul will a book to Jane.
 ‘Mary will give much money to Susan, and Paul will a book to Jane.’
- c. Mary vil gi mange penger til Susan og Paul vil _ til Jane.
 Mary will give much money to Susan and Paul will to Jane.
 ‘Mary will give much money to Susan, and Paul will to Jane.’¹³
- d. Mari vil gi flere bøker til Siri enn Pål vil _ til Kari.
Mary will give more books to Siri than Paul will to Kari.
 ‘Mary will give more books to Siri than Paul will to Kari.’
- e. *Mari vil gi Siri flere bøker enn Pål vil _ Kari.
 Mary will give Siri more books than Paul will Kari.
 ‘Mary will give Siri more books than Paul will Kari.’
- f. *Mari vil gi Siri flere bøker enn Pål vil _ CDer.
 Mary will give Siri more books than Paul will CDs.
 ‘Mary will give Siri more books than Paul will CDs.’

¹³ (49c) is in sharp contrast to its counterparts with a non-prepositional direct or indirect remnant, which were rated unacceptable. This also holds in the case of the usually more accepted comparative, cf. (49e) and (49f).

(50) Prepositional Complements (Icelandic):

- a. Pétur hefur lesið fleiri bækur fyrir Kara-ACC en Páll hefur _ fyrir María-ACC.
Peter has read more books for Kari than Paul has for Maria.
'Peter has read more books for Kari than Paul has for Maria.'
- b. (?)Pétur vill biða lengur eftir María en Páll vill _ eftir Jóni.
Peter will(wants-to) wait longer after Maria than Paul wants after Jóni.
'Peter will wait longer for Maria than Paul will for John.'
- c. Pétur vill leika lengur við Maríu en Páll vill _ við Jóni.
Peter wants-to play longer with Maria than Paul wants-to with John.
'Peter wants to play longer with Maria than Paul wants with John.'

(51) Dative Construction (Icelandic):

- a. María myndi skila fleiri bókum til Péturs en Páll myndi _ til Jóns.
Maria will return more books to Peter than Paul will to John.
'Maria will return more books to Peter than Paul will to John.'
- b. ??María myndi skila fleiri bókum til Péturs en Páll myndi blöðum _ til Jóns.¹⁴
Maria will return more books to Peter than Paul will newspapers to John.
'Maria will return more books to Peter than Paul will newspapers to John.'
- c. **María myndi gefa Pétri fleiri bækur en Páll myndi _ blöð.
Mary will give Peter more books than Paul will newspapers.
'Mary will give Peter more books than Paul will newspapers.'
- d. ??María myndi gefa Pétri fleiri bækur en Páll myndi _ Jóni.
Mary will give Peter more books than Paul will John.
'Mary will give Peter more books than Paul will John.'

¹⁴ Presumably, the difference in acceptability is due to the double remnant. Glenda Newton (p.c.) points out that the (British) English counterparts of (49a), (49b), and (51b) are also unacceptable, at least for some speakers.

The Scandinavian data seem to obey the generalisation in (52) below.

(52) Scandinavian Pseudogapping Remnant Generalisation:

Scandinavian Pseudogapping mostly has prepositional remnants, i.e. prepositional phrases or a prepositional dative. Moreover, it occurs almost exclusively in comparative constructions.

This assumption is corroborated with evidence from Icelandic, as we will see in the next section.

2.2.2. Pseudogapping in Icelandic: Prepositional Remnants

The first striking point to note about Pseudogapping in Icelandic is that there seems to be a verb class specific difference. Whereas verbs that belong to the *gefa* class ('give') of verbs (classification according to Holmberg & Platzack 1995) don't seem to allow Pseudogapping, verbs of the *skila/ræna* class (return/rob) (classification according to Holmberg & Platzack 1995) show Pseudogapping, as in (53).

(53) María myndi skila fleiri bókum til Péturs en Páll myndi til Jóns.

Maria will return more books to Peter than Paul will to John.

'Maria will return more books to Peter than Paul will to John.'

As we examine the two verb classes in question, we will see that the occurrence of Pseudogapping is closely linked to the respective verb classes allowing the *to*-construction at all or not.

2.2.2.1. Pseudogapping in the *gefa* verb class

The table below (54) shows the main verbs of the *gefa* verb class (as classified by Holmberg & Platzack 1995). The two important verbs for our purposes here are *gefa* ('to give') and *senda* ('to send').

(54)

Verb	Meaning	Case of the IO	Case of the DO
<i>gefa</i>	<i>give</i>	<i>DAT</i>	<i>ACC</i>
segja	say (tell)	DAT	ACC
<i>senda</i>	<i>send</i>	<i>DAT</i>	<i>ACC</i>
synja	show	DAT	ACC

Two examples for the object distribution (i.e. accusative following dative) are given in (55) and (56) (examples taken from Holmberg & Platzack 1995:187).

(55) Jón gaf Ólafi bókina.

Jon gave Olaf-DAT a-book-ACC

‘John gave Olaf a book.’

(56) Hún sagði þeim sögu.

She told them-DAT a-story-ACC

‘She told them a story.’

Most ditransitive verbs in Mainland Scandinavian (and in English) show either the order DP > DP or DP > PP (i.e. either the double-object construction (DOC) or the *to*-construction). In Icelandic, however, the *to*-construction is *not* permitted in the *gefa* verb class, as (57) and (58) show for the verb *gefa* (‘to give’), and (59) and (60) for the verb *synja* (‘to show’) (all examples taken from Holmberg & Platzack 1995:188).

(57) Ég gaf Jóni bókina.

I gave John-DAT a-book-ACC.

‘I gave John a book.’

(58) *Ég gaf bókina til Jóns.

I gave a-book-ACC to John.

‘I gave a book to John.’

(59) Hún sýndi mér málverk sín.

She showed me pictures her

‘She showed me her pictures.’

(60) *Hún sýndi málverk sín fyrir mig/til mín.

She showed pictures her for me /to me.

‘She showed her pictures to me.’

The sentence in (60) also shows that other prepositions that would be plausible in the context in Icelandic are also ruled out.

In order to place indirect objects in sentence-final position, the *gefa* verb class can change the order of the objects from indirect object preceding direct object (IO > DO) to direct object preceding indirect object (DO > IO), thus employing *inversion* instead of a preposition. The inversion process presumably is a syntactic process which inverts the two objects. The examples in (61) and (62) (taken from Collins/Thráinsson 1993:150) illustrate the two possible word orders.

(61) Hann gaf konunginum ambáttina.

He gave the-king-DAT the-maidservant-ACC.

‘He gave the king the maidservant.’

(62) Hann gaf ambáttina konunginum.

He gave the-maidservant-ACC the-king-DAT

‘He gave the maidservant to the king.’

Pseudogapping, as said above, does not occur in the *gefa* class ((63) – (65)).¹⁵

(63) *María myndi gefa Pétri fleiri bækur en Páll myndi Jóni blöð.

Mary will give Peter more books than Paul will Joni newspapers.

‘Mary will give Peter more books than Paul will John newspapers.’

¹⁵ (63) is attested marginally acceptable only by one speaker (as is (65)).

(64) **María myndi gefa Pétri fleiri bækur en Páll myndi blöð.

Mary will give Peter more books than Paul will newspapers.

‘Mary will give Peter more books than Paul will newspapers.’

(65) ??María myndi gefa Pétri fleiri bækur en Páll myndi Jóni.

Mary will give Peter more books than Paul will John.

‘Mary will give Peter more books than Paul will John.’

Clearly, the absence of Pseudogapping in the *gefa* class does not yet point to a correlation between the occurrence of Pseudogapping and the general possibility of the *to*-construction. The Pseudogapping pattern with the verb *senda* looks very similar to the pattern above with *gefa* at first, as shown in (66) to (68) below.

(66) *María myndi senda Pétri fleiri bækur en Páll myndi Jóni blöð.

Mary will send Peter more books than Paul will John newspapers.

‘Mary will send Peter more books than Paul will John newspapers.’

(67) **María myndi senda Pétri fleiri bækur en Páll myndi blöð.

Mary will send Peter more books than Paul will newspapers.

‘Mary will send Peter more books than Paul will newspapers.’

(68) ??María myndi senda Pétri fleiri bækur en Páll myndi Jóni.

Mary will send Peter more books than Paul will John.

‘Mary will send Peter more books than Paul will John.’

However, contrary to Holmberg and Platzack’s (1995) generalisations, it seems that the verb *senda* allows the *to*-construction.¹⁶ Then, on the basis of the grammaticality of Scandinavian Pseudogapping examples with prepositional remnants we might expect that Pseudogapping with the prepositional variant of *senda* should be allowed (and fully grammatical) in this case. This prediction is borne out (69).

¹⁶ K. Ottósson (p.c.).

(69) *María myndi senda fleiri bækur til Péturs en Páll myndi til Jóns.*

Mary will send more books to Peter than Paul will to John.

‘Mary will send more books to Peter than Paul will to John.’

These data permit the conclusion that there is at least a very strong preference for the prepositional remnant in Pseudogapping (as indicated in the generalisation in (52)), and that there is indeed a correlation between a verb allowing the *to*-construction and the occurrence of this verb in Pseudogapping. This hypothesis is corroborated by evidence from the *skila/ræna* class of verbs that allow the *to*-construction.

2.2.2.2. Pseudogapping in the *skila/ræna* verb class

The *skila/ræna* verb class shows a greater variation in case assignment, depending on the verb. This is illustrated in the table below (70).

(70)

Verb	Meaning	Case of the IO	Case of the DO
<i>skila</i>	<i>return</i>	<i>DAT</i>	<i>DAT</i>
<i>ræna</i>	rob	ACC	DAT
<i>óska</i>	wish	DAT	GEN
<i>leyna</i>	hide	ACC	DAT
<i>spytja</i>	ask	ACC	GEN

Some examples with these verbs are shown in (71) and (72) (taken from Holmberg & Platzack 1995:188).

(71) *María skilaði mér bókinni minni.*

Maria returned me-DAT the-book-DAT my-DAT

‘Maria returned me my book.’

(72) *Þeir rændu Ólaf peningunum.*

They robbed Olaf-ACC the-money-DAT

‘They stole the money from Olaf.’

The *skila/ræna* class generally permits the *to*-construction, as is illustrated in (73) to (75) (from Holmberg & Platzack 1995:205).

(73) Hún skilaði bókinni til Jóns.

She returned the-book to John.

‘She returned the book to John.’

(74) Þeir ætluðu að ræna veskinum af mér.

They intended to rob the-purse of me.

‘They intended to steal my purse of me.’

(75) Jón leyndi sannleikanum fyrir Maríu.

John concealed the-truth for(of) Maria.

‘John concealed the truth from Maria.’

As shown above, Pseudogapping occurs with *skila* (76) with the prepositional variant.

(76) María myndi skila fleiri bókum til Péturs en Páll myndi til Jóns.

Maria will return more books to Peter than Paul will to John.

‘Maria will return more books to Peter than Paul will to John.’

(77) ??María myndi skila fleiri bókum til Péturs en Páll myndi blöðum til Jóns.

Maria will return more books to Peter than Paul will newspapers to John.

‘Maria will return more books to Peter than Paul will newspapers to John.’

(78) *María myndi skila fleiri bókum til Péturs en Páll myndi blöðum.

Maria will return more books to Peter than Paul will newspapers.

‘Maria will return more books to Peter than Paul will newspapers.’

These data from Scandinavian (in particular, Icelandic) suggest that there is indeed a strong preference for prepositional remnants, and, what is more, this observation seems to carry over to other languages as well, in particular, Portuguese, as illustrated in the next section.

2.2.3. Pseudogapping in Portuguese

Given the generalisation that Scandinavian employs prepositional remnants in a construction similar to Pseudogapping in comparative structures, the question arises whether other languages actually exhibit a similar pattern with ellipsis in comparatives. It seems that Portuguese might be a case in point. Consider the following data from European and Brazilian Portuguese.¹⁷ The example in (79) (Brazilian Portuguese) shows that the ellipsis structure is ungrammatical with a bare remnant, i.e. with a non-prepositional remnant, in both coordinate and comparative structures. Once the determiner is added to the object, which is possible, the sentence improves, and is considered only slightly marginal, as illustrated in (80) (Brazilian Portuguese).

(79) a. *Joao convidou Maria, e Sarah vai _ Jane.

John invited Mary, and Sarah will _ Jane.

‘John invited Mary and Sarah will Jane.’

b. *Joao vai convidar Maria mais vezes do que Sara vai _ Pedro.

John will invite Mary more often than Sarah will _ Pedro.

(80) ? Joao tem convidado ao Pedro mais vezes do que Sara tem _ ao Joao.

John has invited to-the-Pedro more often than Sara has to-the-Joao.

‘John has invited Pedro more often than Sara has John.’

In European Portuguese, on the other hand, the use of the article with proper names is much more common (if not the default). In (81) (European Portuguese) below, we see that this does not make a coordinated structure with ellipsis grammatical, but that the comparative structure in (82) (European Portuguese) is judged grammatical.

(81) *O John convidou a Sarah, e a Mary vai _ a Jane.

the-John invited the-Sarah, and the-Mary will _ the-Jane.

‘John invited Sarah, and Mary will Jane.’

¹⁷ I am very grateful to Sonia Cyrino and Gabriela Matos for providing these Portuguese data.

(82) O Joao tem convidado a Sara mais vezes do que a Maria tem _ a Joana.

the-Joao has invited the-Sara more often than the-Maria has _ the-Joana.

‘Joao has invited Sara more often than Maria has Joana.’

It seems, then, that a Pseudogapping-like construction is available in Portuguese (both in Brazilian and European Portuguese), but only with the preposition/definite article preceding the proper name. In European Portuguese, where the use of the determiner in front of the proper name is more common, the construction is considered more natural than its counterpart in Brazilian Portuguese. While both variants of Portuguese make use of regular auxiliaries in these constructions, a second Romance language, French, in turn, exhibits a Pseudogapping-like construction only with modal auxiliaries, as we will see in the next section.

2.2.4. Pseudogapping in French

Busquets and Denis (2006) note that there is a construction of modal ellipsis in French that resembles English Pseudogapping, as illustrated in (83) (Busquets and Denis 2006: 13, their (41)).

(83) Alice ne peut pas s’acheter de jouets, mais [des livres] elle (*le) peut.

They point out that in this instance, the object *des livres* seems to have moved out of the entire clause, not only out of the ellipsis site. In my opinion, these examples can thus be aligned with the cases of Pseudogapping involving topicalisation in English, first noted in Levin, and given in (84) below (Levin 1986: 47, her (18)).

(84) Some of these materials I use. And some I don’t Ø.

(Writers at Work)

Levin (1986: 47) suggests that in these cases, since the non-topicalised counterparts are very awkward, the topicalisation is necessary, as the object in question does not carry enough contrast with respect to the antecedent. However, this is not quite the case in the French example above. On the basis of this conjecture, we could hypothesise that in the French

example, topicalisation (or focus movement) is employed to establish the relevant contrast in Pseudogapping. Obviously, this idea requires extensive qualification, especially with respect to focus movement in French.

Before I move on to the previous accounts of Pseudogapping, I would like to draw attention to an observation made in Busquets and Denis (2006: 3, fn. 3). Referring to Miller (1997), they note that in Old French and Middle French, the auxiliary verbs *avoir* (have), *estre* (be), and *faire* (do) belonged to a class of verbs that was distinct from regular verbs, and functioned like English auxiliaries do today. Busquets and Denis (ibid.) suggest that they behaved like the English auxiliary *do*, and claim that these auxiliaries thus licensed VP Ellipsis and Pseudogapping. As of yet, I have not been able to confirm this claim, and will thus leave it for future research.

3. Previous Accounts of Pseudogapping

Levin (1978, 1986) was the first to provide an in-depth discussion of the phenomenon of Pseudogapping. One conclusion from her approach consists in the claim that the structural derivation of Pseudogapping seems closer to the derivation of VP Ellipsis than to the derivation of Gapping.¹⁸ Given that the surface structure of Pseudogapping resembles both VP Ellipsis in having a finite auxiliary, and Gapping, in also having a contrastive object remnant, the Pseudogapping accounts in the literature seem to fall in exactly two categories: analyses that treat Pseudogapping as a variant of VP Ellipsis, and those that consider it a special instance of Gapping. I will address both of these theories in turn.

3.1. Pseudogapping as an instance of VP Ellipsis

The idea that Pseudogapping is a special instance of VP Ellipsis has found many proponents in the literature. Despite individual differences in the respective analyses, which I will consider below, the points that are common to all of these approaches treat questions such as constituent structure, the licensing process involved in Pseudogapping (which obviously should be similar to the process licensing process of VP Ellipsis), and are based on the assumption that Pseudogapping is VP deletion which occurs after the Pseudogapping remnant has vacated the VP. Not surprisingly, however, each author has a different conception of the nature of this movement, as we will see in the discussion on movement in subsequent chapters. The main distinction between the hypotheses suggested in the literature can be captured in the opposition of A-movement versus A-bar-movement.

In what follows, I will briefly summarise each of the individual approaches, starting with the A-movement account, and point out the claims that are specific to the proposals, before I

¹⁸ As an analysis in terms of phrase structure rules is not very accessible in current syntactic theory, I refer the reader to Levin (1978, 1986) and Gengel (2002) for details.

move on to a more detailed discussion of the issues arising from these analyses in the next chapter.

3.1.1. A-Movement Analysis: Overt Object Shift

The assumption that Pseudogapping is VP Ellipsis is also adopted in Lasnik's analysis (Lasnik 1995a, 1999a, and subsequent work). Lasnik proposes that the movement process responsible for the movement of the remnant out of the VP is an instance of *Object Shift*, an A-movement operation. Lasnik's (1995a, 1999a) object shift analysis for a sentence such as (1) is spelt out in (2), with the relevant tree structure in (3) below (omitting the antecedent).

(1) John invited Sarah, and Mary did Jane.

(2) John invited Sarah, and Mary did [_{AgroP} Jane_i] [_{VP} invite ~~t_i~~].

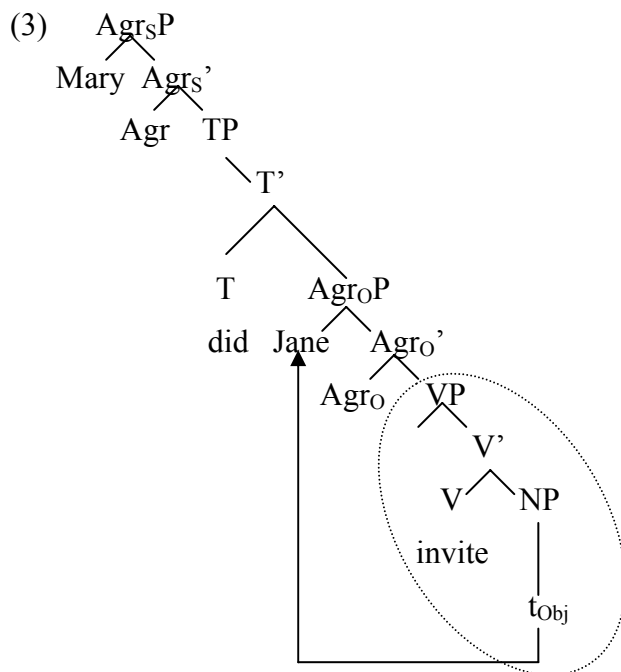

According to Lasnik, the object moves into the specifier position [_{Spec,Agro}]. This movement is, in its essence, taken to be independent of case (contrary to Kennedy and

Merchant's 2000 interpretation; cf. also Boeckx 2000).¹⁹ Rather, it is triggered by an EPP-feature on Agr_O (Lasnik 1995a, 1999a), causing object shift to [Spec, Agr_O].

Crucially, this object shift is an overt movement operation in Pseudogapping, to allow for the PF deletion of the VP. Object shift as such is generally conceived to not take place overtly in English. However, Lasnik (1995a and subsequent work) as well as Koizumi (1993) argue against this assumption. I will address this issue in more detail in the following chapter.

In sentences that might turn out to be Pseudogapping constructions after object movement, there is a certain kind of optionality, in the sense that non-pseudogapped versions of Pseudogapping sentences are mostly fine. This is shown in (4) below, where no deletion has taken place.²⁰

(4) John invited Sarah more often than Mary invited Jane.

Lasnik's analysis accounts for this optionality by linking it to the optionality of the EPP feature (for objects). The EPP feature itself is optional, but if it enters the derivation, it triggers obligatory movement of the object.

With respect to the verb, Lasnik adopts Koizumi's (1995) assumption that all verbs raise overtly in English.²¹ In Pseudogapping, however, according to Lasnik, it does not raise but stays inside the VP. While its features are moved and checked, its lexical content fails to be pied-piped. Hence, in order to prevent the derivation from crashing at PF, the VP, including the offending material, is deleted.

Finally, turning to the question of constituent structure, Lasnik's (1995a, 1999a) analysis also provides a solution to the problem with the ellipsis as such in Pseudogapping, since there,

¹⁹ To be precise, Lasnik (1995a) assumes that the relevant case features are checked along with the EPP-feature, but that the movement as such happens for EPP rather than case reasons (which is a valid assumption in the light of numerous examples of Pseudogapping with PP remnants).

²⁰ There are exceptions to this generalisation, however. Kennedy & Merchant (2000: 99, fn. 9) point out examples of attributive comparative deletion, where the non-pseudogapped counterpart was rated less acceptable than the pseudogapped version:

- i. They sell better shirts than they do ties.
- ii. ??They sell better shirts than they sell ties.

²¹ Johnson (1991) was the first to propose this in connection with object shift. Koizumi (1995) combines this with a split VP structure, also adopted by Lasnik.

deletion apparently affects a discontinuous parts of the structure, and non-constituents. Based on the assumption that the object undergoes object shift, but that the verb is not moved out of the VP, Lasnik proposes that the combination of these two factors can explain why *prove...guilty* in a sentence such as (5) (Lasnik 1995a: 146, his (26)) is, in fact, a constituent, which can be targeted by ellipsis.

(5) The DA proved Jones guilty and the Assistant DA will ~~prove~~ Smith ~~guilty~~.

In overt syntax, *prove...guilty* is not considered to be constituent. However, one could assume a stage in the derivation, where the ECM subject *Smith* has raised to [Spec,Agr_O], leaving a trace in the small clause *prove...guilty*. Crucially, at this stage, the verb is still inside the VP. Thus, the remaining material could form a VP that could be deleted.²²

In its essential points, this analysis is adopted in Baltin (2000, 2003) who insists that the movement in Pseudogapping must be A-movement. (I will include his analysis in the discussion of A-movement vs. A-bar-movement in the argumentation in the following chapters.)

Richards (2001: 135ff.) proposes a Pseudogapping analysis which also involves overt object movement. He suggests that Pseudogapping could receive a similar explanation as Gapping, where he assumes that remnant movement targets multiple specifiers of a single head.²³

The crucial factor in his analysis, however, is his definition of strong and weak features. Based on the dichotomy between strong and weak features proposed in Chomsky (1995) (cf. also the discussion in chapter 4), Richards contends that weak features, i.e. features that do not trigger overt movement, may become strong under certain circumstances. In ellipsis contexts, therefore, the features on the head attracting the Pseudogapping remnant are usually not active in overt syntax. However, ellipsis causes these weak features to be strong, i.e. to be capable of driving syntactic movement (Richards 2001: 137).

²² For the specific treatment of the trace in question see Lasnik (1995a: 147).

²³ I will not go into the details of the specific movement analysis here, which, as far as I can see, is a version of the object shift approach, in its adaptation in the multiple specifier theory.

As we will see in the next chapters, however, the object shift analysis faces the predominant problem of not being able to account for the focus effects found in Pseudogapping, which is easily incorporated in the A-bar-movement analyses that I will discuss in the next section. Moreover, the problem arises as to whether the EPP, the trigger of the A-movement that is claimed to be responsible for Pseudogapping, can derive all the properties of Pseudogapping. I will discuss these issues, and related issues, in the next chapter(s).

3.1.2. A-bar-Movement Analyses

The other group of analyses that treat Pseudogapping as an instance of VP Ellipsis with prior movement of the remnant out of the ellipsis site consider the movement of the remnant to be an instantiation of A-movement, which is implemented with either Heavy Noun Phrase Shift (henceforth Heavy NP Shift or HNPS), as illustrated in the next section, or with Focus movement.

3.1.2.1. Heavy NP Shift

Jayaseelan (1990) proposes that Pseudogapping is a special instance of VP Ellipsis, with prior movement of the remnant out of the VP. He starts his discussion with the observation that the deletion of a non-constituent structure constitutes a theoretical problem, which makes it difficult to account for the examples given in (6a-c) below (Jayaseelan 1990: 64, his (1)).

(6) a. Mary hasn't dated Bill, but she has \emptyset Harry. (\emptyset = dated)

b. Speaker A: Is she suing the hospital?

Speaker B: She is \emptyset the doctor. (\emptyset = suing)

c. Speaker A: Has he sold his collection yet?

Speaker B: He has \emptyset some of the paintings; I'm not sure about the rest. (\emptyset = sold).

He therefore suggests that the remnants are able to undergo an extraposition process, which is licensed by contrastive stress (focus). On the basis of the contrast in acceptability between the example in (6b) above and its counterpart in (7) (Jayaseelan 1990: 65, his (1d')), he

concludes that the remnants are always contrastively stressed, a property which makes the constituents sufficiently “heavy” (as he calls it, *ibid.*). This allows them to undergo extraposition, as schematised in (8), which shows the structural configuration prior to the deletion process.

(7) Speaker A: Is she suing the hospital?

Speaker B: *Yes, she is \emptyset it.

(8) Mary hasn't [_{VP} [_{VP} dated t_i] Bill]_i, but she has [_{VP} [_{VP} dated t_j] Harry]_j].

In (8), the extraposed elements are adjoined to VP. Jayaseelan (1990: 65) thus proposes that the extraposition process is an instance of Heavy Noun Phrase Shift (HNPS), or “Focus NP Shift” (in Rochemont’s 1978 terminology). HNPS is considered to adjoin an NP to the right of a VP, in order to focus it. This is illustrated in the examples in (9) (Jayaseelan 1999: 65, his (4)).

(9) a. They [_{VP} brought [_{NP} the man who was being interrogated] into the room]

b. They [_{VP} [_{VP} brought t_i into the room] [_{NP_i} the man who was being interrogated]]

In (10), the same process is applied to particle shift (an analysis Jayaseelan attributes to Kayne 1985, with α being a small clause). We will return to particle shift later.

(10) a. John [_{VP} looked [_{α} [_{NP} the information] up]]

b. John [_{VP} [_{VP} looked [_{α} t_i up]] [_{NP_i} the information]]

On the basis of these data, Jayaseelan (1990: 66) proposes that the extraposition process in Pseudogapping is also an instance of HNPS. He supports his claim with the following three arguments.

Firstly, HNPS obligatorily pied-pipes a preposition when an object of a preposition is moved ((11a-c), Jayaseelan 1990: 66, his (7)), even if the related processes of *wh*-movement and NP movement do not pied-pipe the preposition ((11d-e), Jayaseelan 1990: 66, his (7)).

- (11) a. John counted [PP on a total stranger] for support.
 b. John counted for support on a total stranger.
 c. *John counted on for support a total stranger.
 d. Who did John count on for support?
 e. A total stranger was counted on for support.

This observation leads Jayaseelan (1990: 66) to predict that the object of a preposition does not occur as a Pseudogapping remnant without its preposition. This is borne out, as shown in (12) (*ibid.*, his (8)).²⁴

- (12) a. You can't count [PP on a stranger]; but you can count [PP on a friend]
 b. You can't count on a stranger; but you can on a friend.
 c. *You can't count on a stranger; but you can a friend.

Secondly, Jayaseelan (1990: 66) notes that multiple HNPS is ungrammatical in general (13) (Jayaseelan 1990: 66, his (9)).²⁵ Likewise, Pseudogapping cannot have more than one remnant (14) (*ibid.*, his (10)).²⁶

- (13) *It proved to the jury his guilt that John was seen with the murder weapon.
 (vs. It proved his guilt to the jury that John was seen with the murder weapon.)

- (14) *I didn't give a dime to Mary, but I did a nickel to Jane.

The third argument that Jayaseelan provides is the "Focus (or Heaviness) Constraint on the extraposed constituent", which is observed in both HNPS and Pseudogapping (Jayaseelan 1990: 67).

A final point concerns the derivation Jayaseelan proposed in (8) above (here repeated as (15)). He originally suggested that Heavy NP Shift also applied to the object in the antecedent.

²⁴ Levin (1986) actually judged (12c) to be grammatical.

²⁵ Example (13) is attributed to Stowell (1981: 161, 216ff.), who shows that multiple adjunction to VP is ungrammatical.

²⁶ Note that Jayaseelan (1990: 66) concedes that the judgement of ungrammaticality in (13) and (14) is not shared by all speakers, which weakens his conclusion somewhat. Incidentally, he does not state specifically whether the speaker judgements applied to both examples in a consistent manner.

(15) Mary hasn't [_{VP} [_{VP} dated t_i] Bill]_i, but she has [_{VP} [_{VP} dated t_j] Harry]_j].

This hypothesis is not tenable, however, since otherwise, the example in (17), which is a modified version of (16) (Jayaseelan: 1990, his (1)), would be grammatical. As Jayaseelan puts it, (17) would only ever be acceptable with heavy stress on *you*, but even then “it is not the sentence we wished to generate” (Jayaseelan 1990: 72).

(16) Speaker A: Gee, I've never seen you on campus before.

Speaker B: Yeah! Neither have I you.

(17) Speaker A: ??Gee, I've never seen on campus before you.

Speaker B: Yeah! Neither have I you.

However, Jayaseelan points out (Jayaseelan 1990: 72) that it is only the remnant in the Pseudogapping examples which receives obligatory contrastive stress. The corresponding element in the antecedent may be, but need not be, emphasized, i.e. is not necessarily a focus constituent in the strict sense. For instance, *you* in Speaker A's utterance in (16) is not extraordinarily stressed. Since, in his view, the identity condition on deletion must only be satisfied at the LF level, Jayaseelan concludes that the NP in the antecedent need not move overtly but rather undergoes extraposition only at LF, while the object remnant moves overtly in the syntax.

The idea that Heavy Noun Phrase Shift is responsible for the movement processes in Pseudogapping is also taken up in Johnson (2005). He gives the examples in (18) and (19) to demonstrate that Pseudogapping and Heavy NP Shift are similar in that both DPs and PPs seem to be moved out of the VP (Johnson 2005: 1f., his (6) and (7)).

(18) a. He [_{VP} met John], but he didn't Ø Sally.

b. She [_{VP} talked to John], but she didn't Ø to Sally.

(19) a. He [_{VP} met yesterday] the children who saw him try to jog.

b. She [_{VP} talked] endlessly to anyone who dared to look at her.

In his account of VP Ellipsis in terms of phonological projections, Johnson (2005: 11) needs to assume that any movement out of elided VPs should be impossible.²⁷ This is obviously not borne out in the Pseudogapping cases or in examples such as (20) (ibid., his (47)), where the complement of an elided VP has left the VP prior to deletion.

(20) What has Bush done and what hasn't he \emptyset ?

This problem then leads Johnson to the hypothesis that, in contrast to the account given in Jayaseelan (1990), it is not the heavy NP that moves, but rather the VP. Essentially following the analysis first proposed in Larson (1988), Johnson contends that the verbal complex adjoins to v , and is subsequently elided. The structural configuration is thus as in (21b) (Johnson 2005: 12, his (52)), where the subscript e indicates deletion.

(21) a. She might give to me something replaceable, but she wouldn't \emptyset something important.

b.

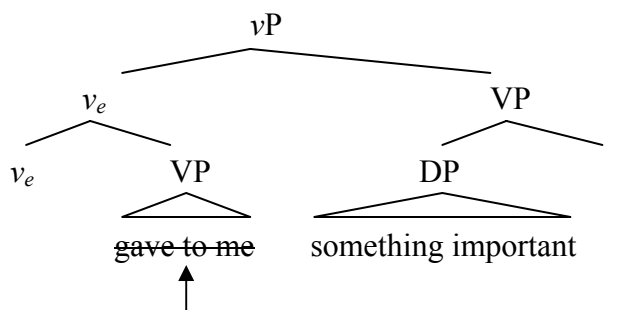

Finally, a “reduced” version of Heavy Noun Phrase Shift is proposed in Takahashi (2003a, b, 2004a), who contends that both object shift and Heavy NP Shift are necessary to derive all instances of Pseudogapping, with Heavy NP Shift accounting for the structures with direct object remnants and prepositional remnants.²⁸

²⁷ For a discussion of his account see chapter 8.

²⁸ Cf. chapter 4 and 5 (and to some extent, chapter 6) for a detailed account of Takahashi's (2003a, 2004a) analysis.

We will see in subsequent chapters of this dissertation that the Heavy NP Shift analysis faces some problems with respect to the distribution of Pseudogapping remnants, not all of which seem to be amenable to a Heavy NP (or XP) analysis. One of the most striking counterexamples, presumably, is the one noted in Kennedy and Merchant (1997: 11, their (71)), given in (22) below. On the assumption that Heavy NP (or XP) targets constituents this would probably rule out *as psychotic* in (22) as a Pseudogapping remnant.

(22) Herman strikes psychiatrists as friendly more often than he does [as psychotic].

The next section discusses focus movement, which is conceived to be leftward A-bar-movement, which, crucially, is not as sensitive to the kind of remnant left over in Pseudogapping.²⁹

3.1.2.2. Focus Movement

Jayaseelan (2001) argues for a focus position situated above the ν P level. Assuming this position, he claims, allows us to explain a variety of phenomena such as the positioning of question words in Malayalam, the derivation of cleft constructions in English and Malayalam, the structural configuration of the clause-final focus marker in English, and the derivation of English Pseudogapping.³⁰

With regard to the structural configuration proposed in his paper, Jayaseelan proposes that the attributes associated with the outer specifier of ν P (as assumed by Chomsky) can be captured more adequately with a topic and focus position above ν P, as suggested in his analysis. Thus, the derivation for a sentence such as (23) is as in (24), where a Focus Phrase is situated above the ν P.

(23) John invited Mary, and Jane did Bill.

²⁹ Indeed, this peculiarity of focus movement is conceived to be one of the greatest disadvantages of such an account, as Baltin (2000) notes.

³⁰ In addition to the Focus Phrase, Jayaseelan assumes an iterable Topic Phrase, placed above the focus phrase. According to him, this provides an account for a different range of phenomena, such as the definiteness/specificity constraints on clause-internal scrambling in Malayalam, Dutch, German, and Yiddish, and on Scandinavian object shift. Moreover, the analysis suggested by Jayaseelan has some consequences on the treatment of the difference between SOV and SVO languages, which I will not treat here.

(24)

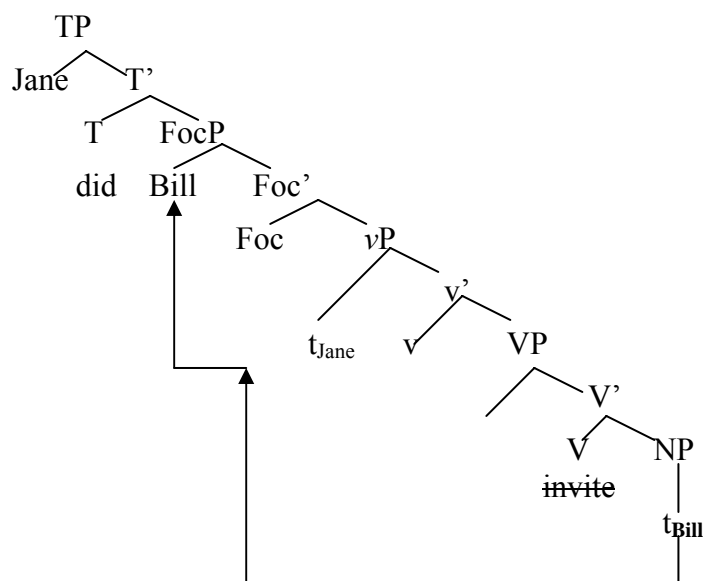

As this is principally the analysis that I will adopt in my own proposal, I will discuss it in more detail in chapter 6, and provide detailed arguments and motivation for the assumption of focus movement in Pseudogapping. The next section in this chapter is devoted to analyses that are not easily classified in terms of A-movement vs. A-bar-movement, since they combine rather than oppose the two kinds of movement.

3.1.3. Hybrid Analyses

In this subsection, I will briefly discuss two analyses that do not fall into either category of A-movement or A-bar-movement. Dutch Scrambling, for instance, seems to be considered A-bar-movement by Johnson (1996, 2001), while it is considered to be A-movement in Baltin (2000, 2003). Moreover, as already mentioned above, Takahashi (2003) proposes a hybrid account, considering both HNPS (A-bar-movement) and OS (A-movement) to be necessary for the derivation of all Pseudogapping remnants.

In what follows, I will summarise Johnson's (1996a, 2001) scrambling approach (as mentioned above, I will discuss Baltin's analysis in detail in the next chapter). Then, I will briefly introduce the main claims of Takahashi's (2003a, b, 2004a) eclectic approach, which will be discussed in more detail in the subsequent chapters of this dissertation.

3.1.3.1. Dutch Scrambling

Johnson (2001: 461) proposes that the movement which causes the Pseudogapping remnants to leave the VP is similar to Dutch Scrambling. This operation targets both object pronouns and prepositional phrases and thus, on first sight, seems to capture the lack of restrictions on the Pseudogapping remnants better than an HNPS or OS approach. Like HNPS, Scrambling does not strand prepositions, which accounts for another empirical fact about Pseudogapping.³¹ Moreover, Scrambling can be a long-distance movement, as shown in (25) (Johnson 2001: 462, his (80)).

- (25) ... dat Jan *Marie* heeft geprobeerd [*t* te kussen]
... that Jan Mary has tried to kiss
(... that John has tried to kiss Mary)

Thus, long-distance Pseudogaps such as in (26) to (28) can be accounted for (Johnson 2001: 461, his (78) and (79), taken from Levin 1986: (7) and (13), 15-16; (27) from Johnson 1996a: 85, his (33a)).

- (26) a. I'm sure I would like him to eat fruit more than I would _ cookies.
b. I think you need to show yourself more than you do _ anyone else.

- (27) a. ?While I wouldn't like him to eat cookies, I would _ fruit.
b. ?While I think you need to examine yourself, you don't _ anyone else.
c. While Truman doesn't want to visit every city, he does _ Barcelona.

- (28) Then the police started to pick up soloists – like they did [e] you.

Moreover, Johnson (2001: 462) points out that the restrictions concerning long-distance Dutch Scrambling and Pseudogapping are very similar. Specifically, long-distance scrambling is restricted to a limited choice of non-finite complement clauses (as also illustrated with its ungrammaticality in finite complement clauses in (29b) (Johnson 2001:

³¹ Johnson (1996a: 86) notes that one exception to this claim is the Scrambling of R-pronouns, which is replicated in English only in Sluicing contexts.

462, his (82)), and does not occur in adjunct clauses, as shown in (29a) (ibid., his (82)). The same restrictions hold for Pseudogapping, as illustrated in (30) (Johnson 2001: 463, his (83)).

(29) a. *... dat Jan het boek *zijn vader* gelezen heeft [om *t* te pliezeren]
... that John the book his father read has C⁰ to please
(... that John has read the book to please his father)

b. *...dat Jan *de Krant* beweert [dat Sam *t* leest]
... that John the paper claimed that Sam read
(... that John claimed that Sam read the paper)

(30) a. *While Rusty might leave in order to please Mag, he won't _ his father.
b. *While Doc might claim that O.J. Berman had read his book, he wouldn't _ the paper.

A final argument for the claim that Pseudogapping involves Dutch Scrambling is the observation that verbal particles do not figure as remnants in Pseudogapping, and neither undergo Dutch Scrambling, as shown in (31) and (32) (Johnson 2001: 463; his (84) and (85); (85) cited from Zwarts 1993: 221).

(31) a. *While Perry might switch the TV OFF, he won't [e] ON.
b. *I'll turn the radio DOWN, but I won't [e] UP.

(32) a. *... dat Jan de TV uit steeds zet.
... that Jan the TV out all the time puts
b. ... dat Jan de TV steeds uit zet.
... that Jan the TV all the time out puts

However, there are reasons to believe that Dutch Scrambling is not the appropriate type of movement for English Pseudogapping. First of all, it is hard to motivate its presence in the grammar of English, a problem that it shares with the majority of movement operations that have been suggested for Pseudogapping. Secondly, it fails to comply with the Binding effects that will be discussed in chapter 5. Moreover, while the examples given in (26) above can be explained with Dutch Scrambling, the problem is that Dutch Scrambling can only move

across *non*-finite sentence boundaries. A final counterargument, and, presumably, the most crucial one, is that the Dutch Scrambling type (as A-movement) is not able to move prepositional phrases, which, however, as we have seen from the data, frequently occur as Pseudogapping remnants.³²

The next section deals with an account that employs both A-movement and A-bar-movement, in order to account for all types of remnants in Pseudogapping.

3.1.3.2. *The Eclectic Approach: Heavy NP Shift and Object Shift*

Takahashi (2003a, b, 2004a) argues that both rightward movement and leftward movement of the Pseudogapping remnant are needed to account for all instances of Pseudogapping. For a sentence such as in (33) (taken from Lasnik 1999a: 141), the structures for rightward and leftward movement are illustrated in (34a) and (34b) below.

(33) John will select me, and Bill will ~~select~~ you.

(34) a. Rightward Movement Approach:

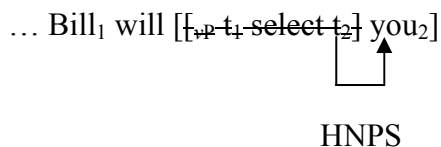

b. Leftward Movement Approach:

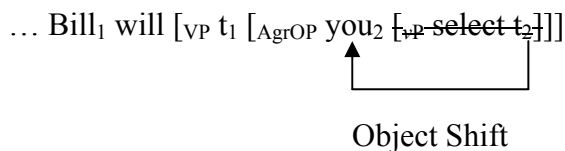

Takahashi (2003a, b, 2004a) adopts Lasnik's (1999b and subsequent papers) claim that for indirect object remnants in Pseudogapping (cf. (35)), the HNPS analysis is not available, as suggested by the ungrammaticality of (36) (taken from Larson 1988: 354).

³² Thanks to Martin Salzmann for very helpful discussion of this point.

(35) Although he wouldn't give Bill the book, he would ~~give~~ Susan ~~the book~~.

(36) *Max gave t₁ a book about roses [the tall man in the garden]₁.

With respect to Object Shift, Takahashi (2003a, b, 2004a) suggests that it cannot account for the derivation of Pseudogapping with direct object remnants, since in these cases, the assumption that ellipsis targets constituents turns out to be problematic, as shown in (37b), where a non-constituent structure seems to be elided.

(37) a. Although he wouldn't give Bill the book, he would the paper.

b. [TP he₁ would [VP t₁ [AgrP₂ Bill₂ [VP₂ t₂ [AgrP₃ the paper₃ [~~VP₃ give t₃]]]]]]]]~~

According to Takahashi, the Split-VP analysis proposed in Lasnik (1995a, 1999a) (cf. the next chapter for a detailed discussion) does not yet provide an answer to the question whether long object shift is actually possible, i.e. whether the direct object can be moved over the indirect object, as illustrated in the structure in (38). The conflict between his analysis and Lasnik's approach, however, may be due to the fact that in Lasnik's (1995a, 1999a) account, examples such as (38) are deemed ungrammatical.³³

(38) [TP he₁ would [VP₁ t₁ [AgrP₁ [AgrP₂ the paper₂ [~~VP₂ give Bill t₂]]]]]]~~

Takahashi (2003a, b, 2004a) provides an answer to this problem on the basis of Scandinavian data.³⁴ As is known from Anagnostopoulou's work (Anagnostopoulou 2002), English seems to behave like Icelandic and Danish rather than Swedish and Norwegian. In Icelandic (and Danish), only the indirect object can be shifted, as shown in the Icelandic examples in (39) (Icelandic; quoted from Anagnostopoulou 2002: 7).³⁵

³³ I have not been able to solve this empirical dispute. There seems to be a tendency that speakers find examples such as (38) slightly marginal, but not ungrammatical. Thanks to Howard Lasnik for valuable comments on this problem.

³⁴ Note here that Takahashi establishes a parallel between English-type object shift, and Scandinavian object shift, which, as we will see in chapter 4, is not entirely straightforward.

³⁵ Takahashi (2003a) notes that (39b) is grammatical with certain verb classes. The underlying order of objects in these cases is direct object > indirect object, however (cf. Holmberg and Platzack 1995).

- (39) a. Ég skilaði manningum ekki bókinni.
 I returned the-man-DAT not the-book-DAT
 b. *Ég skilaði bókinni ekki manningum.
 I returned the-book-DAT not the-man-DAT
 ‘I did not return the book to the man.’

The same situation is reflected in the passive construction, where Icelandic and Danish only allow the indirect object as a subject of a passive, as shown in (40) for Icelandic (from Anagnostopoulou 2002: 8). Again, English behaves like Icelandic and Danish, as illustrated in (41) (from Larson 1988: 362).

- (40) a. Jóni var skilað bókunum.
 John-DAT was returned the-books-DAT
 b. *Bókunum var skilað Jóni.
 the-books-DAT was returned John-DAT
 ‘The book was returned to John.’

- (41) a. Mary was sent a letter.
 b. ?*A letter was sent Mary.

Takahashi (2003a) thus suggests that, since English does not allow the passivisation of the direct object, the direct object should not be able to undergo Object Shift, hence, an analysis of direct object remnants in Pseudogapping in terms of Object Shift is ruled out. This argument, however, is not unproblematic, since for Lasnik (1995a, 1999a, and subsequent papers), the passivisation facts actually constitute an argument *in favour* of an A-movement analysis.³⁶

Takahashi’s own proposal, the ‘eclectic approach’, involving both Object Shift and Heavy NP Shift, is illustrated in (42) and (43), for the derivation of the Pseudogapping remnants in a double object construction.

³⁶ I will return to this problem in the following chapter(s). Thanks to Howard Lasnik for valuable comments on this point.

(42) *Direct object remnant in double object construction*

a. Although he wouldn't give Bill the book, he would ~~give Bill~~ the paper.

b. ... he₁ would [_{VP} [_{VP} t₁ give Bill t₂] the paper₂]

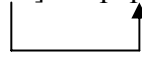

HNPS

(43) *Indirect object remnant in double object construction*

a. Although he wouldn't give Bill the book, he would ~~give Susan the book~~.

b. ... he₁ would [_{XP} Susan₂ [_{VP} t₁ give t₂ the book]]

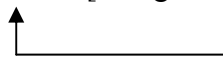

Object Shift

On the basis of these observations, Takahashi (2003a) concludes that both the HNPS approach and the Object Shift approach are partially correct, in deriving direct object remnants (and PPs), and indirect object remnants, respectively.

I will now turn to the other group of approaches to Pseudogapping that I mentioned in the introduction to this chapter, that is, the analyses that treat Pseudogapping as a variant of the Gapping construction.

3.2. Pseudogapping as an instance of Gapping

There are a number of approaches in the literature that seem to equate Pseudogapping more with Gapping than with VP Ellipsis. In what follows, I will discuss two of these approaches that are fairly similar to one another in nature. Given that the Pseudogapping patterns more with VP Ellipsis, as pointed out in chapter 2, I will not pursue this line of argument in the remainder of this dissertation, taking it for granted that Pseudogapping is more related to VP Ellipsis than it is to Gapping.

3.2.1. Across-the-Board Movement

Zoerner and Agbayani (2000) propose that Gapping and Pseudogapping may receive the same derivation. Building on the assumptions in Johnson's (1994) account of Gapping, they suggest that not only Gapping but also Pseudogapping can be derived with across-the-board (ATB) movement.

Zoerner and Agbayani (2000: 550) modify the ATB account for Gapping so as to involve vP coordination rather than VP coordination. For Pseudogapping, they assume that it can be derived via across-the-board movement of the verb out of the vP and a lower CP. This is schematised in (45) below (Zoerner and Agbayani 2000: 553, their (13)) for the sentence given in (44).

(44) Robin could speak French better/before Kim could Russian.

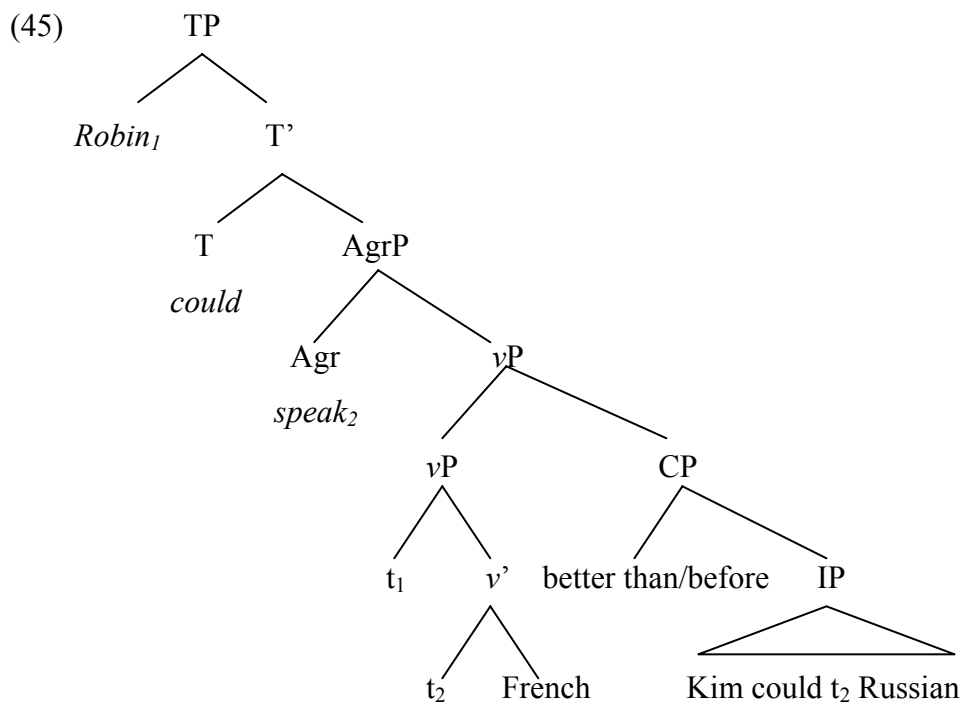

The key points of Zoerner and Agbayani's (2000) analysis are the following. Crucially, the ATB movement of the verb is asymmetric in their account, as the phrases that are conjoined do not have the same type. A second point is that the verb movement in question is entirely

optional, and a third feature is that the object remnant in Pseudogapping ends up higher than the vP level.

In their analysis, the preference for Gapping over Pseudogapping, and the observation that Gapping is more widespread than Pseudogapping cross-linguistically, is due to the observation that Gapping involves symmetric coordination, and symmetric ATB movement. They incorporate this insight into a second type of approach that they put forward in Agbayani and Zoerner (2004), where they claim that the derivation of Pseudogapping and Gapping involves sideways movement.

3.2.2. Sideways Movement

Agbayani and Zoerner (2004) propose that Pseudogapping can also be derived via sideways movement, on the basis of the Across-the-Board (ATB) account outlined above. They argue that Pseudogapping is thus related to Gapping, which was analysed as ATB movement in Johnson (1994), and involves verb movement – to be precise, sideways movement (cf. Nunes 2001 for an account of sideways movement). Their unification of Pseudogapping with the Gapping construction rather than VP Ellipsis is partly due to the observation that “both constructions serve a similar discourse function (different altogether from VP Ellipsis): to contrast VP-internal elements across two “clauses” (Agbayani and Zoerner 2004: 187; they attribute the observation to Levin 1986).

Keeping the adjunct structure as proposed in Zoerner and Agbayani (2000) in (45) above, and maintaining their claim that Pseudogapping also involves verb movement (to an Aspect head), Agbayani and Zoerner (2004) suggest that sideward movement applies in Pseudogapping, as a last resort strategy. This strategy is necessary since the numeration in Pseudogapping contains only one verb, as illustrated in (46) (Agbayani and Zoerner 2004: 195, their (22)) for the sentence in (47) (Agbayani and Zoerner 2004: 186, their (2)).

(47) They like rutabagas more than they do ~~like~~ lima beans.

(48) $N = \{they(2), rutabagas, lima\ beans, more\ than, like, do, T, v(2), Asp(2), C\}$

Therefore, the verb must be moved from its position within the adjunct to the matrix clause, in order to be able to license *rutabagas*, apart from *lima beans*. On the assumption that the adjunct clause gets spelled out before it is merged with the matrix VP, the verb is copied and merged with the object of the main clause, *rutabagas*, and discharges its thematic properties to this object.³⁷

From the above, the conclusion must be drawn that for the derivation to converge, the verb movement has to take place before the adjunct is spelled out. This is schematised in (49) (Agbayani and Zoerner 2004: 196, their (23)).

(49)

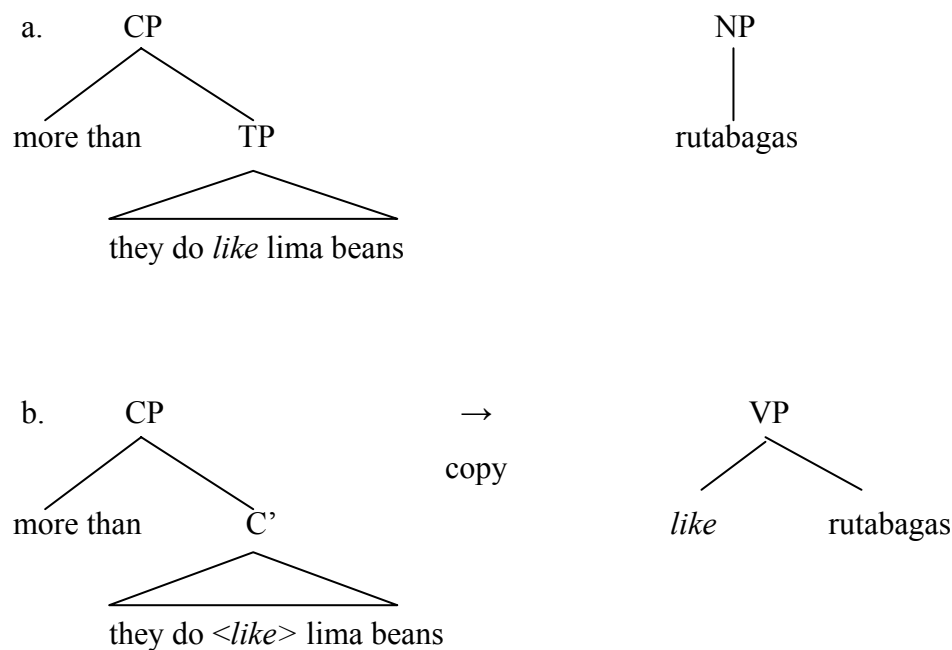

Combining the adjunct clause with the matrix VP thus yields the structure given in (50) (Agbayani and Zoerner 2004: 196, their (24)).

(50) [_{VP} like rutabagas [_{VP} [_{CP} more than they do <like> lima beans]]]

³⁷ Note that Agbayani and Zoerner (2004: 197) assume that the verb remains active to discharge the thematic properties to the object of the matrix clause after it has discharged the thematic properties to the object of the adjunct clause.

The final configuration, which includes verb raising from V to an Aspect head in Agbayani and Zoerner's (2004) approach, is illustrated in (51) below (Agbayani and Zoerner 2004: 196, their (26)).

(51) [TP They T [AspP like [VP <like> rutabagas [VP [CP more than they do <like> lima beans]]]]]

Crucially, then, as in the Across-the-Board movement approach, the deletion site is only apparent, in being derived via movement rather than deletion.

In the last part of this chapter, I will discuss the Cyclic Linearization Approach put forward in Takahashi (2004a), which translates the Pseudogapping derivation via object shift into a cyclic linearization framework.

3.3. The Cyclic Linearization Approach

Building on ideas put forward in Fox and Pesetsky (2003), Takahashi (2004) suggests that the object shift approach proposed by Lasnik (1995a, 1999a) can be captured in terms of Cyclic Linearization.

In Scandinavian, object shift is blocked if the verb has not moved, as illustrated in the Swedish example in (52) (Takahashi 2004: 13, his (51), taken from Holmberg 1999: 1).

- (52) a. Jag kysste henne₁ inte [VP t_v t₁].
 I kissed her not
 b. *Jag har henne₁ inte [VP kysst t₁].
 I have her not kissed

In (52b), the auxiliary blocks the movement of the verb, and, given that the object cannot precede the verb in the surface order, the structure is ruled out. Fox and Pesetsky (2003) are concerned with the derivation of the appropriate linear order of elements at Spell-Out, and propose that this linear order is established via cyclic Spell-out. Crucially, once a relative

order is determined, this order is binding and is preserved throughout the remaining steps of the derivation. The application of this hypothesis to the Pseudogapping case is as follows.

Consider the Pseudogapping example in (53) (Takahashi 2003b, his (49a)).

(53) Although John didn't give Mary the book, he did Sue.

Clearly, the surface order where the object precedes the verb is disallowed, as illustrated in (54) (Takahashi 2004a: 13, his (50)).

(54) *John₁ [_{XP} Mary₂ [_{VP} t₁ gave t₂ the book]].

Fox and Pesetsky (2003) propose that the first Spell-out domain consists of the verb and the object, as shown in (55), with the relative order indicated with '<'.

(55) a. [_{VP} V Obj]] → V<Obj
 b. [_{VP} give Sue the book] → **give<Sue**<the<book

The order between *give* and *Sue* is crucial in the derivation of the Pseudogapping example in (53) (with the linear order of the VP in (55b) above). Given that the relative order between the two elements is **give<Sue** in the first Spell-out domain, this order cannot be reversed during the derivation. If object shift applies without verb movement, we obtain the structure in (56), with the relevant partial ordering in (56b) (compare Takahashi 2003b, his (49)).

(56) a. [_{CP} C [_{TP} he₁ did [_{Sue}₂ [_{VP} t₁ give t₂ the book]]]]
 b. ... * **Sue<give** ...

If, however, as Fox and Pesetsky (2003) and Takahashi (2003b) propose, deletion occurs, the violation of the linear ordering is obviated, as illustrated in (57) (Takahashi 2003b, his (49d)).

(57) a. [_{CP} C [_{TP} he₁ did [_{Sue}₂ [_{VP} ~~t₁ give t₂ the book~~]]]]
 b. he₁<did<Sue<~~give~~
 c. he₁<did<Sue

Thus, Pseudogapping can be derived without problem for the linearization process, since the element causing the violation, that is, the verb, is deleted. As shown in (57c), this results in the correct surface word order of the Pseudogapping example in (53) above.

3.4. Conclusion

In this chapter I have provided an overview of the different approaches to Pseudogapping. I have shown that with regard to analyses that consider Pseudogapping to be related to VP Ellipsis, with movement of the remnant out of the VP, A-movement approaches such as the object shift approach suggested in Lasnik (1995a, and subsequent work), and A-bar-movement approaches such as Heavy NP Shift and focus movement exist side by side in the literature. In the next two chapters, I will thus examine the arguments that have been put forward for the predominant approach, that is, the A-movement approach, in detail, and conclude that the arguments in favour of A-movement can, at least, to a great extent, equally hold in an A-bar-movement account, which has the additional advantage of capturing the focus properties that are germane to Pseudogapping and ellipsis in general.

In the following chapter, I will thus investigate the object shift approach, paying special attention to the EPP as a driving force behind movement, the featural configuration that Lasnik (1995a, 1999a, a.o.) assumes in Pseudogapping. In chapter 5, then, I will discuss the other complex of evidence that has been adduced in favour of an A-movement account of Pseudogapping, that is, evidence from Binding effects.

4. EPP-driven Movement in Pseudogapping

It has been claimed in the literature (Alexiadou and Anagnostopoulou 1997, 1998, 2001) that languages such as English do not only have an EPP requirement for subjects but may also have an EPP requirement for objects. The EPP requirement for both subjects and objects is anchored to a specific projection in the syntactic structure, namely, the Agreement projection for subjects (Agr_SP) and the Agreement projection for objects (henceforth Agr_OP). Alexiadou and Anagnostopoulou (1997, 1998, 2001) show that the EPP requirement is universally strong, that is, that there are no languages without the EPP. Rather, the apparent difference between languages that do not have an overt subject (Null Subject languages, NSLs) and languages such as English lies in the fact that the former type of languages satisfies the EPP via movement of a head into the Agr head position, instead of either merging an expletive or moving an XP in the specifier position of the Agr projection.

While in English, the EPP requirement for subjects has to be satisfied obligatorily, the checking of the categorial features in the Agr_OP projection is an optional process, as pointed out in Alexiadou and Anagnostopoulou (1997, and subsequent work).

In what follows, we will see that the claim made in Alexiadou and Anagnostopoulou's (1997, 1998, 2001) theory that there is an optional EPP requirement for objects in English, which is satisfied via merging or moving an element in the specifier position of Agr_OP, plays a crucial role in Lasnik's (1995a, 1999a, 2001a, a.o.) analysis of the English Pseudogapping construction.

4.1. EPP-driven Object Shift

Lasnik (e.g. 2001a) provides evidence from different structures, such as ECM constructions, complements of unaccusatives, and particle shift constructions, each of which behave as if

the object had been moved to a higher position in the syntactic structure. The movement assumed in these structures is the movement that Lasnik also assumes for Pseudogapping.

In ECM constructions, for instance, which are illustrated in (1) to (3) (Lasnik 2001a: 103f., his examples (1) to (3)), the subjects uniformly display ‘high’ behaviour, namely, Condition A satisfaction (1), attenuation of Weak Crossover effects (2), and the licensing of Negative Polarity Items (3), all of which would be impossible if the ECM subject were situated in the lower clause.

(1) *Condition A*

The DA proved [two men to have been at the scene of the crime] during each other’s trials.

(2) *Weak Crossover*

The DA proved [no suspect_i to have been at the scene of the crime] during his_i trial.

(3) *NPIs*

The DA proved [noone to have been at the scene] during any of the trials.

Crucially, the adverbial clauses are taken to be in the higher clause.

Lasnik’s conclusion that in (1) to (3), the ECM subject must have moved into the higher clause, since otherwise, they could not c-command material in the higher clause (i.e. material inside the adverbials), is also based on the comparatively unacceptable finite counterparts of the examples in (1) to (3) (in (4) to (6), Lasnik 2001a: 104, his (4) to (6)). Here, no movement can be assumed, and no c-commanding with respect to the adverbials is possible.

(4) ?*The DA proved [that two men were at the scene of the crime] during each other’s trials.

(5) ?*The DA proved [that no suspect_i was at the scene of crime] during his_i trial.

(6) ?*The DA proved [that noone was guilty] during any of the trials.

In order to establish a clear parallel between the behaviour of ECM subjects and other, regular objects, Lasnik provides examples (in (7) to (9) below, (Lasnik 2001a: 104, his (7) to (9)) to show that with respect to Condition A satisfaction, Weak Crossover, and Negative Polarity Item licensing, the behaviour of transitive objects is similar to the behaviour of the ECM subjects illustrated in (1) to (3) above.³⁸

(7) *Condition A*

The DA accused two men during each other's trials.

(8) *Weak Crossover*

The DA discredited no suspect_i during his_i trial.

(9) *NPIs*

The DA cross-examined none of the witnesses during any of the trials.

Building on the assumption that, even if the ECM subject raised to the regular object position in the higher clause, this position would still be too low to c-command into the adverbial clause, Lasnik (2001a: 104) suggests that both object and ECM subject need to target a still higher position.

The higher position in question is assumed to be the [Spec,Agr_O] position in (11) (Lasnik 2001a: 107, his (19)) below, which illustrates the structural configuration of the ECM construction in (10) (Lasnik 2004, his (11)).^{39,40}

(10) She will prove [Bob to be [t guilty]

³⁸ Here, Lasnik (2001a: 104) builds on arguments from Postal (1974) and Lasnik and Saito (1991).

³⁹ Note that Lasnik (2001a: 107, his (19)) employs the split VP structure proposed in Koizumi (1995).

⁴⁰ There is one point, though, where ECM subjects and objects do not seem to pattern alike, namely in those cases where an ECM subject occurs in a particle shift construction (as pointed out in Alexiadou and Anagnostopoulou 2001: 222). I will come back to this problem later.

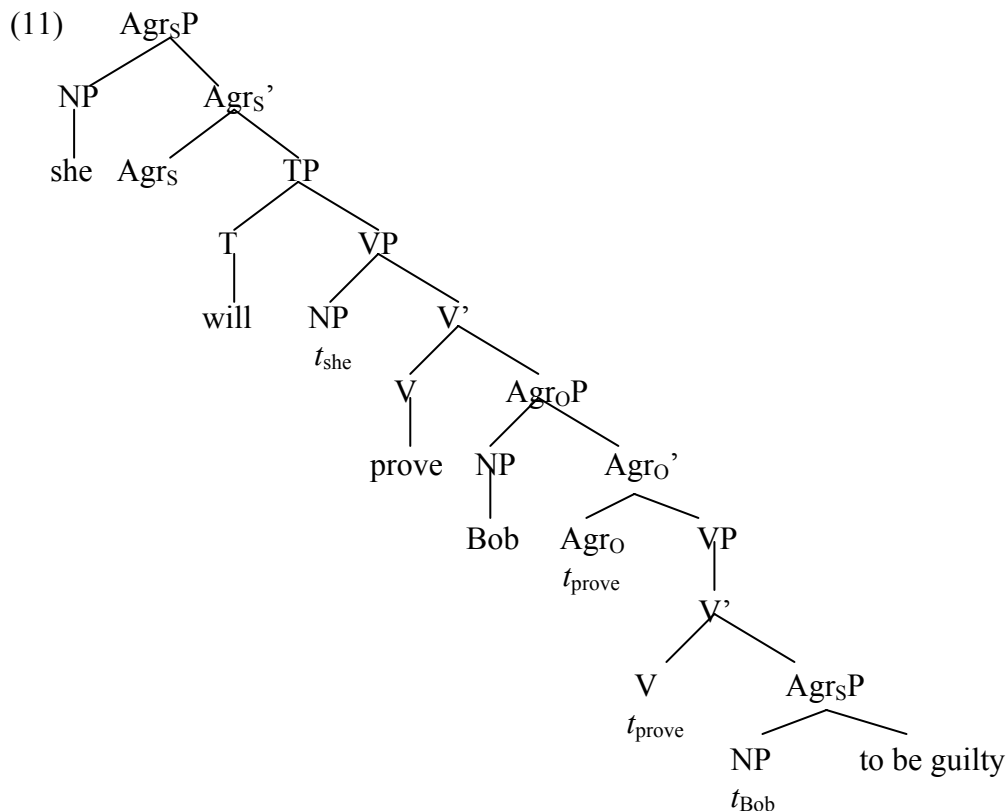

Apart from ECM constructions, it seems that complements of unaccusative verbs also seem to have risen to a higher position in the structure. Consider (12) below (Lasnik 2001a: 108, his (23)).

(12) There arrived two knights on each other's horses.

As observed by Uriagereka (1988), here, *each other* is able to have the associate of the expletive, *two knights*, as an antecedent. This would be unexpected if one assumed that the complement was lower than the adjunct. On the basis of such data, Lasnik (2001a: 109) argues that here too, overt object shift has taken place.

A third instance where overt object shift can be assumed for English are verb-particle constructions, as pointed out by Lasnik (2001a: 111), following Johnson (1991). The relevant examples are given in (13) and (14) below (Lasnik 2001a: 111, his (37) and (38)).

(13) Mary called up friends of John.

(14) ?Mary called friends of John up.

Consider now the combination of particle constructions and ECM subjects (as discussed in Kayne 1985 and Johnson 1991). Indeed, the sentence in (15) below (Lasnik 2001a: 112, his (41)), analysed in both Kayne and Johnson as infinitival counterpart of (16) (ibid., his (42)), can easily be treated as involving overt movement of the subject of the ECM clause, *John*.^{41,42}

(15) Mary made John out to be a fool.

(16) Mary made out that John is a fool.

In each of the examples given above, an element, either the ECM subject, the complement of an unaccusative, or the object in a verb-particle construction move into the specifier of an Agr_oP projection, thus satisfying the EPP.

As claimed in Alexiadou and Anagnostopoulou (1997, 1998, 2001), the EPP for objects in English is optional. This is illustrated in the examples given in Lasnik (2001), which I will present in the next section.

4.2. The Optionality of the EPP for Objects

Lasnik (2001a: 112) suggests that scope ambiguities in ECM constructions (as discussed in Chomsky 1995) provide an argument for the claim that overt object shift in ECM constructions is optional rather than obligatory. In (17) below (Lasnik 2001a: 112, his (47), quoted from Chomsky 1995: 327), on the assumption that A-movement does not reconstruct, the scope ambiguity can be derived: whereas in the (a) example, negation scopes over the quantifier, this is not possible in the (b) example.

- (17) a. (it seems that) everyone isn't there yet
 b. everyone seems [*t* not to be there yet]

⁴¹ As originally proposed in Johnson (1991).

⁴² Cf. fn. 33 above.

This behaviour is reflected in the contrast between (18) and (19) below (Lasnik 2001a: 114, his (51) and (53)). In (18), the ECM is in its original position, and the narrow scope reading is possible, i.e. that the subject takes scope under negation, resulting in the (possible, if a bit disfavoured) interpretation that ‘not everyone has arrived yet’.

(18) I believe everyone not to have arrived yet.

(19) Everyone is believed not to have arrived yet.

The reading that not everyone has arrived yet is excluded in the example in (19), however, since here, the universal must take scope over negation, due to its being raised into subject position. On the basis of this contrast in the possibility of the narrow scope reading, Lasnik (2001a: 114) concludes that in these cases, too, object shift should be regarded as optional.

A more complex example is the particle construction with ECM subjects (as in (15) above, here repeated as (20)). Lasnik shows, however, that the situation in (21) (repeated from (17)) is very similar to the situation in the *make-out* ECM construction (Lasnik 2001a: 113), as illustrated in (22) and (23) (*ibid.*, his (48) and (49)). In (23), the ECM subject is in its base position, in (22), a raising operation has taken place.

(20) Mary made John out to be a fool.

(21) a. (it seems that) everyone isn't there yet
b. everyone seems [*t* not to be there yet]

(22) The mathematician made out every even number not to be the sum of two primes.

(23) The mathematician made every even number out not to be the sum of two primes.

In (23), we find that the correct interpretation, i.e. that ‘not every even number is the sum of two primes’ is available. In (22), however, the ECM subject with the universal has raised into a higher position, which prohibits the ECM subject from receiving an interpretation inside the

scope of the negative element. That is, the interpretation that (22) yields is that ‘no even number is the sum of two primes’, which, in mathematical terms, is clearly wrong.⁴³

With respect to verb-particle constructions, there is evidently reason to assume that object shift is optional there, too.

(24) Mary made John out to be a fool.

(25) Mary made out John to be a fool.

In the latter examples, the contrast between the sentences in (24) and (25) (from Lasnik 2004: 2, his (26) and (28), attributed to Kayne (1985) and Johnson (1991)) clearly indicates that the EPP-driven movement of the ECM subject to a position that is higher than [Spec,IP] is optional rather than obligatory. That is, in (24), according to Lasnik and Saito (1991), the ECM subject has raised into the higher clause, arguably to [Spec,Agr_O], whereas in (25), no such movement can be detected. From the above we can conclude that object movement in particle constructions is optional (cf. also Johnson’s (1991) account).⁴⁴

⁴³ Lasnik (2001a: 114f.) provides examples that illustrate a further scope reconstruction problem, which also supports the argument that object shift is optional. As a detailed discussion of this ‘Quantifier Lowering’ phenomenon would lead too far afield from the topic of discussion, I refer the reader to the account of these data in Lasnik (2001a).

⁴⁴ However, the movement of ECM subjects, which is optional in contexts without particle constructions, as we have seen, seems to have a more controversial status with particle verbs. As shown in (24) and (25), in Lasnik’s (2001a) account, the movement of the ECM subject is optional. This hypothesis, however, is not uncontested. In Alexiadou and Anagnostopoulou (2001: 222), sentences that are similar to (24) and (25) above are judged as unacceptable if the object has not undergone movement, as illustrated in (i) (Alexiadou and Anagnostopoulou 2001: 222, their (i)).

- (i) a. John made Mary out to be a liar.
b. *John made out Mary to be a liar.
c. Mary looked (the information) up (the information).”

On the basis of the data in (i), Alexiadou and Anagnostopoulou (2001: 222) conclude that at least in these contexts, the ECM subject seems to move *obligatorily* past the particle, which makes ECM subjects unlike regular objects, for which object movement is optional. This apparent problem seems to be reducible to speaker variation, as Lasnik points out (p.c.): about 50 percent of his informants judged the sentence in (25), here repeated as (ii), as grammatical (the variation is indicated with %), the other 50 percent judged it to be ungrammatical.

- (ii) %Mary made out John to be a fool.

It seems, then, that half the speakers that were asked consider the movement of the ECM subject in this case to be obligatory, while the other half considered it to be optional.

The optionality of object shift is tied to the EPP requirement, which in turn, is related to the Agr_O projection. Lasnik (1999a, a.o.) thus suggests that following the claim made in Chomsky (1995), given below (26), the optionality of object shift should be expressed in terms of the optionality of the Agreement projection for objects.

(26) “If Agr has no strong feature, then PF considerations, at least, give no reason for it to be present at all, and LF considerations do not seem relevant... Agr exists only when it has strong features.”⁴⁵

Hence, Lasnik (2001a: 119) concludes that “the optionality of raising is the optionality of Agr_O. If Agr_O is present, overt raising will be forced by its EPP requirement... If Agr_O is absent, there will be no overt raising”.⁴⁶ However, one question that still remains unaccounted for is why in English, Agr_SP should be obligatory and Agr_OP should not (Lasnik 2001a: 119), a question that probably will not be easy to answer, if it can be answered at all.

4.3. The Pseudogapping Derivation

On the basis of the discussion above, we can thus conclude that in Pseudogapping, the object moves to the specifier of Agr_OP, driven by the EPP, as illustrated in (27) and (28).

(27) John invited Sarah, and Mary did [_{Agr_OP} Jane_i] [_{VP} invite ~~t_i~~].

⁴⁵ Chomsky (1995: 350, quoted in Lasnik 2001a: 119; cf. also Alexiadou and Anagnostopoulou 1998: 519).

⁴⁶ Note that this seems to differ from the account of obligatory object shift proposed in Lasnik (1995a, 1999a) on the basis of Johnson (1991), and Koizumi (1995), and recently revived in Hornstein, Nunes and Grohmann (2005). The overall consensus in the literature, to the best of my knowledge, also appears to favour an optional rather than an obligatory object shift operation in English. I will thus assume that object movement in English is optional, and, presumably, limited to the cases outlined above.

(28)

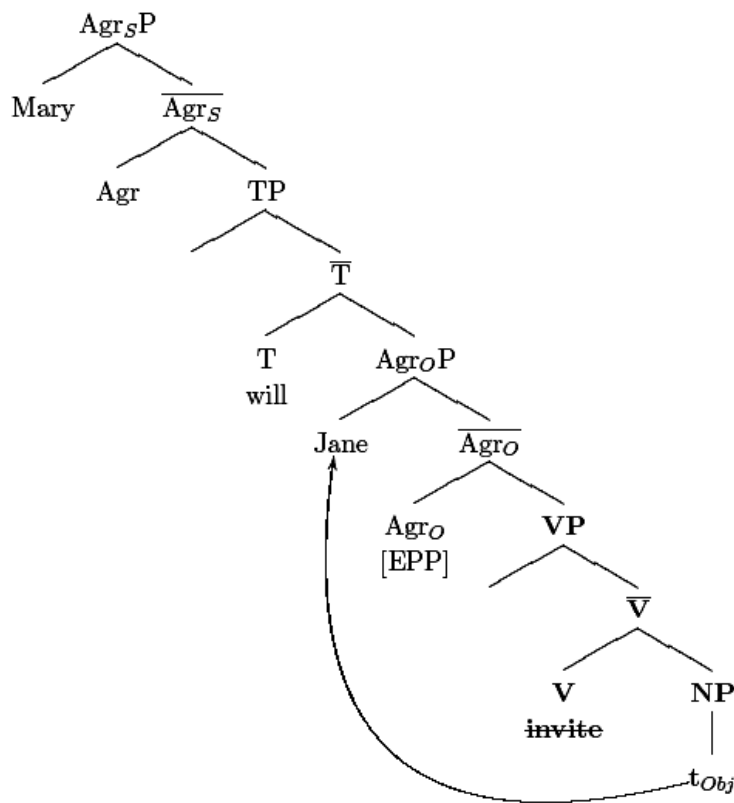

The movement of the object in Lasnik's (1995a, 1999a) approach, results in a violation of syntactic principles, as the object moves past the verb. This is clearly illicit in non-Pseudogapping contexts, as the examples in (29) and (30) (both sentences are taken from Lasnik 2005a, with (29a) modified with the ~~believe~~ material).

(29) a. You might not believe me but you will Bob ~~believe~~.

b. *You will Bob believe.

(30) You will believe Bob.

Thus, in Lasnik's account, the verb either would have to move, if the object moved overtly in non-Pseudogapping contexts, or else, it would have to be deleted in Pseudogapping, to ensure convergence at the PF level. If the verb had to be accommodated in overt structure, Lasnik (1995a, 1999a) suggests a configuration like the one in (31) (Lasnik 1995a: 150, his (43)) below, which employs a 'split VP' structure (following Koizumi 1995).

(31)

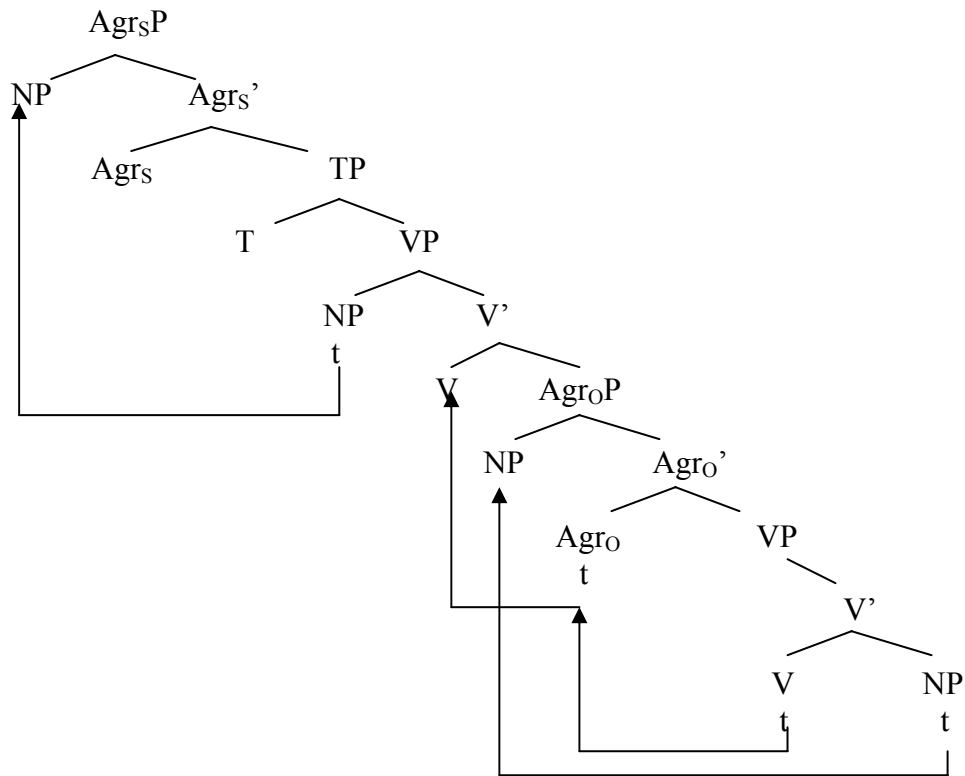

However, as object shift only applies optionally, and as in Pseudogapping, where it applies, the VP is deleted, verb movement to a higher projection does not have to be assumed. This is also the conclusion put forward in Lasnik's (1995a, 1999a) account. I will return to the issue of verb movement in chapter 8, when I discuss the deletion process in more detail.

4.4. Problems for the Object Shift Account of Pseudogapping

In this section, I point out some problematic issues that arise with the object shift approach. The first argument against the object shift approach to Pseudogapping is based on Takahashi's (2003a, b, 2004a) claim that object shift cannot derive all instances of Pseudogapping.

4.4.1. Scandinavian Object Shift and Object Shift in English

In Lasnik's (1995a, 1999a) analysis, as we have seen above, the relevant object shift operation is triggered by the EPP feature, thus, independent of Case. As such, then, it has no

trouble in also deriving remnants that would otherwise be excluded from object movement to a case-checking position, namely, prepositional remnants.⁴⁷

In Takahashi's (2003a, b, 2004a) account of Pseudogapping, however, object shift in English is considered to pattern with its original counterpart, that is, Scandinavian object shift. Before I turn to a brief discussion of Takahashi's (2003a, b, 2004a) analysis and show how the object shift approach, as advocated in Lasnik's (1995a, 1999a) approach, might fall short of accounting for every type of remnant that we find in Pseudogapping, I give a short summary of the main differences between Scandinavian object shift and its English variant.

The first obvious difference between object shift of the English type and object shift of the Scandinavian type concerns the restrictions on the object undergoing object shift. While English object shift can target both direct objects and indirect objects (the distinction, in fact, often being obsolete due to the lack of overt case marking), as well as prepositional objects, and treats pronouns and full DPs alike, the Scandinavian languages show a more differentiated picture.

The Mainland Scandinavian languages (Norwegian, Swedish, and Danish) differ from Insular Scandinavian (Icelandic, and, to some extent, Faroese) in that the first group allows pronouns to be shifted, but not full DPs. In Icelandic, on the other hand, both pronouns and full DPs can undergo object shift. In addition to this distinction between pronouns and full phrases, the Scandinavian object shift operation does not target prepositional objects.

The second difference is that Scandinavian explicitly does not object shift prepositional phrases (cf. also Gengel 2006f). In contrast, the object shift operation assumed by Lasnik (1995a, 1999a, a.o.) can accommodate prepositional phrases, as the trigger for movement is the EPP.

The third difference between English and Scandinavian object shift that is of interest with respect to the Pseudogapping construction is a restriction with regard to the presence of an auxiliary verb in the sentence where an object should be shifted. Whereas English allows the

⁴⁷ Though see the chapter on focus movement for types of remnant that are still hard to explain under an A-movement approach.

object shift operation irrespective of the presence or absence of auxiliaries, in all Scandinavian languages, once an auxiliary is present in the sentence, object shift is blocked.⁴⁸

As a last point, Holmberg's Generalisation (Holmberg 1999) should be mentioned in this respect, too. One could, in principle, argue that in Pseudogapping, Holmberg's Generalisation also holds, even though the verb does not move. In the spirit of Lasnik's analysis, and work by Anagnostopoulou (2002, 2004), categories that are phonologically empty do not seem to block overt object shift.⁴⁹ In this respect, then, English object shift and Scandinavian object shift seem to pattern alike.

Based on the assumption that object shift in English should pattern with object shift in Scandinavian, Takahashi (2003a) shows that not all Pseudogapping remnants in English can be derived via object shift. More specifically, Takahashi (2003a) suggests that object shift cannot account for the derivation of Pseudogapping with direct object remnants, but that the derivation with indirect object remnants is straightforward, as in (32) below. Concerning the possibilities of movement, this situation is reflected in those Scandinavian languages that are considered to pattern with English, as we will see in what follows.

(32) a. Although he wouldn't give Bill the book, he would Susan.

b. [TP he₁ would [VP₁ t₁ [AgrP₂ Susan₂ [VP₂-t₂ [AgrP₃ [~~VP₃-give the book~~]]]]]]]

With direct object remnants, the object shift account does not comply with the assumption that ellipsis targets constituents, as shown in (33), where a non-constituent structure is elided (both (32) and (33) are taken from Takahashi 2003a).

(33) a. Although he wouldn't give Bill the book, he would the paper.

b. [TP he₁ would [VP t₁ [AgrP₂ Bill₂ [VP₂ t₂ [AgrP₃ the paper₃ [~~VP₃-give t₃~~]]]]]]]

This situation is remedied in Lasnik's account (Lasnik 1995a, 1999a) with the assumption of a Split VP structure, here repeated as (34) (Takahashi 2003a).

⁴⁸ As Howard Lasnik points out (p.c.), English may have a 'lower' Object Shift operation, which is independent of the auxiliary, as opposed to Scandinavian 'higher' Object Shift. I will come back to this issue in the discussion of ECM constructions, where I suggest, following Chomsky (2005) that short (i.e. lower, in Lasnik's terms) Object Shift may apply in ECM constructions.

⁴⁹ For an implementation of this observation in the framework of Cyclic Linearization, see Fox and Pesetsky (2003), and Takahashi's (2004a) account of Pseudogapping in terms of Cyclic Linearization.

(34) [TP he₁ would [VP₁ t₁ [AgrP₁ [AgrP₂ the paper₂ [VP₂ give Bill t₂]]]]]]

However, even with the Split VP structure, the question remains whether long object shift is possible, i.e. whether the direct object moves across the indirect object by Object Shift. If this were possible, Pseudogapping with direct object remnants could also be derived via object shift.

Takahashi (2003a) provides an answer to this question on the basis of evidence from Scandinavian Object Shift. As noted in e.g. Anagnostopoulou (2002: 5), Swedish (and Norwegian) allow both objects to undergo object shift, as illustrated in (35) for Swedish. If none of the objects is shifted, the indirect object precedes the direct object (Anagnostopoulou 2002: 5).

(35) a. Han visade henne inte den.

he showed her not it

‘He did not show it to her.’

b. Han gav den inte henne.

he gave it not her

‘He did not give it to her.’

In Icelandic (and Danish), only indirect objects can be shifted, as shown in the examples in (36) for Icelandic (Takahashi 2003a, quoted from Anagnostopoulou 2002: 7).⁵⁰

(36) a. Ég skilaði manningum ekki bókinni.

I returned the-man-DAT not the-book-DAT

b. *Ég skilaði bókinni ekki manningum.

I returned the-book-DAT not the-man-DAT

‘I did not return the book to the man.’

This situation is reflected in the passive construction, with Swedish and Norwegian allowing both objects to be passivised (37) (Swedish; Anagnostopoulou 2002: 9), and Icelandic and

⁵⁰ Takahashi (2003) notes that (36b) is grammatical with certain verb classes. The underlying order of objects in these cases is direct object > indirect object, however (cf. Holmberg & Platzack 1995).

Danish only permitting the indirect object to be the subject of a passive (38) (Icelandic; Anagnostopoulou 2002: 8).

Crucially, English ((39); from Larson 1988: 362) patterns with the latter group of languages.

(37) a. Johan forärades en medalj.

John was-presented a medal.

‘John was presented a medal.’

b. Medaljen forärades Johan.

the-medal was-presented John

‘The medal was presented to John.’

(38) a. Jóni var skilað bókunum.

John-DAT was returned the-books-DAT

b. *Bókunum var skilað Jóni.

the-books-DAT was returned John-DAT

‘The book was returned to John.’

(39) a. Mary was sent a letter.

b. ?*A letter was sent Mary.

Anagnostopoulou (2002) derives the following correlation between passivization and object shift ((40), as cited in Takahashi 2003).

(40) *Anagnostopoulou’s (2002) Correlation*

Passivization of the direct object across the indirect object is possible if the direct object can undergo Object Shift across the indirect object.

Since English does not allow the passivisation of the direct object, the direct object should not be able to undergo Object Shift, hence, an analysis of direct object remnants in Pseudogapping in terms of Object Shift is ruled out, which is as expected, given the constituent structure in (33) above.

In the table below in (41), Takahashi's (2003, 2004) account is summarised, illustrating which Pseudogapping remnants can be derived via object shift. Importantly, the areas shaded with grey are cases in which Takahashi claims that both Heavy NP Shift and Object Shift could potentially derive the correct Pseudogapping configuration.⁵¹ Note also that prepositional phrase remnants, which are deemed to be the most common remnants in Pseudogapping, according to Levin (1986), cannot be derived via object shift.

(41)

Type of Remnant	Heavy NP Shift	Object Shift
object in transitive clauses (single remnant)	✓	✓
direct object remnant in double object constructions	✓	*
direct object remnant in dative constructions	✓	✓
indirect object in double object constructions	*	✓
indirect object in dative constructions (the PP)	✓	*
two remnants in double object constructions	*twice ✓once (direct object)	✓ ✓once (indirect object)
two remnants in dative constructions (the PP)	*twice ✓once (indirect object)	*twice ✓once (direct object)

If Takahashi's (2003a, b, 2004a) account is correct, it seems that object shift alone cannot account for the full spectrum of Pseudogapping remnants. While this situation could be remedied with the assumption of a special type of object shift that holds in English, as proposed in Lasnik's (1995a, 1999a, a.o.) analysis, there are some effects that are left unaccounted for in an overall object shift theory, namely, effects that relate to binding and parasitic gaps, which I will address in detail in the following chapter.

⁵¹ Though see the discussion in subsequent chapters of this dissertation for an alternative approach.

In the next section, I will discuss some structural problems that arise with EPP-driven movement in a current syntactic framework. This structural argument constitutes but a minor argument against the object shift approach, however, and is highly dependent on the respective assumptions of phrase structure and phase structure.

4.4.2. Structural Issues

Recall that Lasnik's (1995a, 1999a) analysis of Pseudogapping (in (42)) was based on the following syntactic configuration in (43) below, with the Agreement projections.

(42) John invited Sarah, and Mary will Jane.

(43)

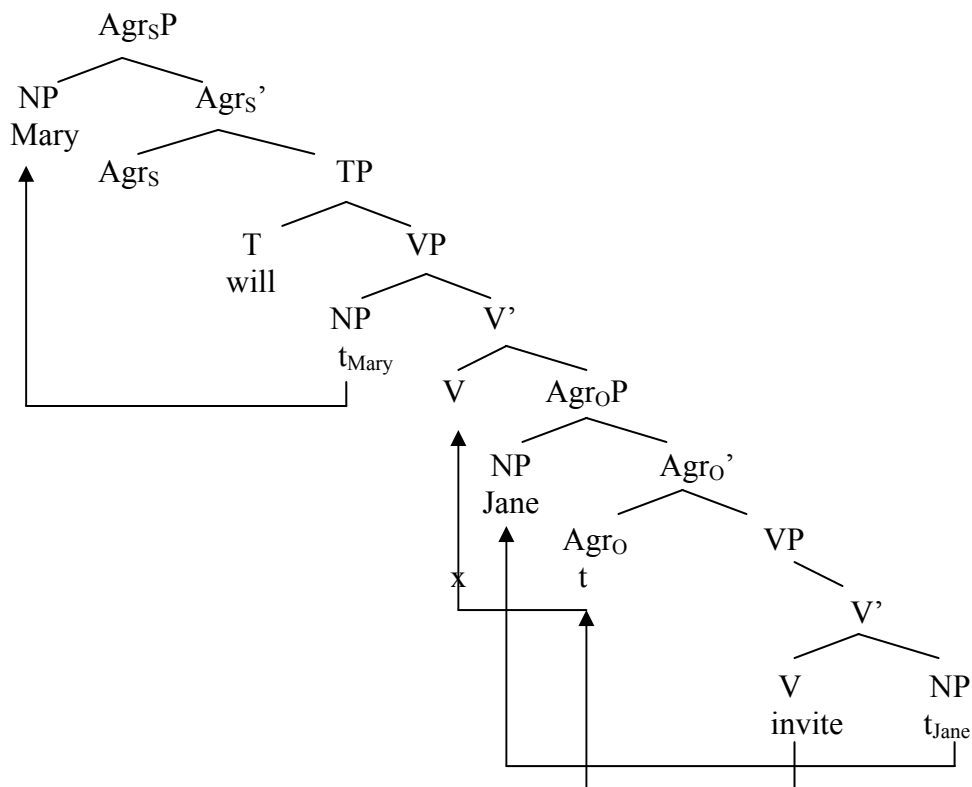

Transferring this account into a more recent syntactic structure, we may replace the agreement projection with the v P layer (following assumptions in e.g. Hornstein, Nunes &

Grohmann 2005, ch. 5).⁵² Then, the object could move to the outer specifier of the *vP* projection, as illustrated in (64) below.

With the structure schematised in (44), however, the *Agr_OP* position, which was originally assumed to be in between the two V layers (in the split VP structure, or, later, presumably in between *vP* and VP, cf. Lasnik 2001a: 121), is now higher up in the clause, in the *vP* layer.⁵³

(44)

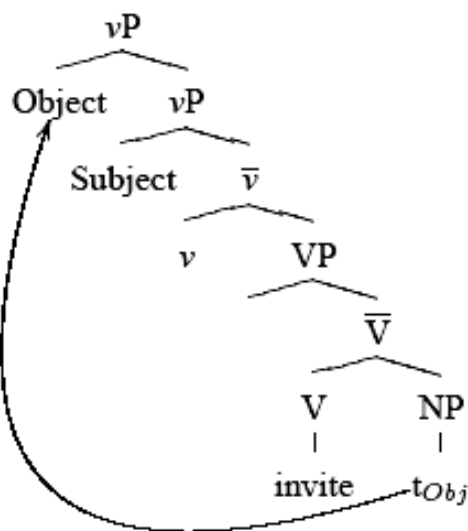

On the assumption that the configuration in (64) is appropriate for Pseudogapping, the position that has been suggested for other cases of EPP-driven movement, i.e. ECM constructions and particle shift constructions is actually a lower one. According to Chomsky (2001, 2005), ECM cases, for instance, should be treated as involving movement to the specifier of VP (not *vP*), cf. (45) below.

The structure in (45), however, would again point to a structure, where, just as in Lasnik's (1999a, a.o.) analysis, the relevant projection that the object moves to is placed in between the lower VP and the higher *vP* level. This is also the stance adopted in Alexiadou and Anagnostopoulou (2001: 222) who also suggest that, if there is object movement at all, e.g. in particle constructions, it should be movement to a target that is located inside the VP.

⁵² Chomsky (1995: ch. 4.10) proposed that the agreement projections could actually be replaced with multiple specifiers (i.e. on TP and VP), since the specifiers of *Agr_SP* and *Agr_OP* merely served as landing sites for movement. Moreover, the respective heads, *Agr_S* and *Agr_O* were no longer considered to host the relevant features, which were taken to reside exclusively on T and on V. (See Mohr 2005: 17 for discussion.)

⁵³ Cf. also the discussion on this topic in later sections of this chapter.

If no additional level is adopted, however, Lasnik's account does not go through for Pseudogapping, as illustrated in (46) and (47) below. While the object remnant could, in principle, target the position assumed in Chomsky's (2001, 2005) account for ECM construction, as schematised in (66), the necessary deletion operation for Pseudogapping cannot take place, since only the V-bar level could be deleted, instead of the entire VP.⁵⁴ Thus, it seems that a different landing site for the object has to be found, to ensure phrasal deletion in Pseudogapping.

(45)

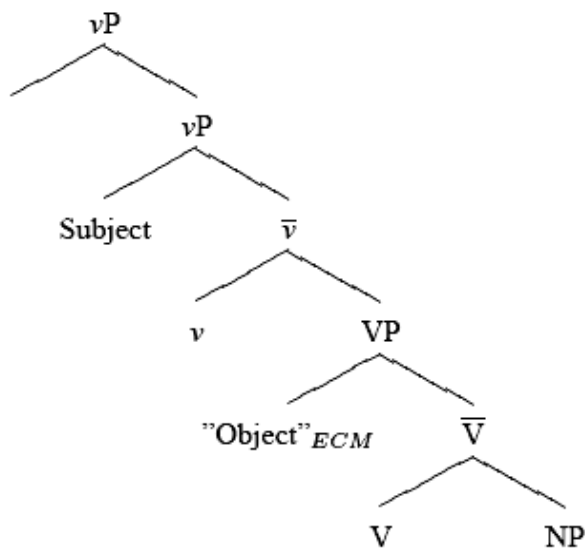

(46)

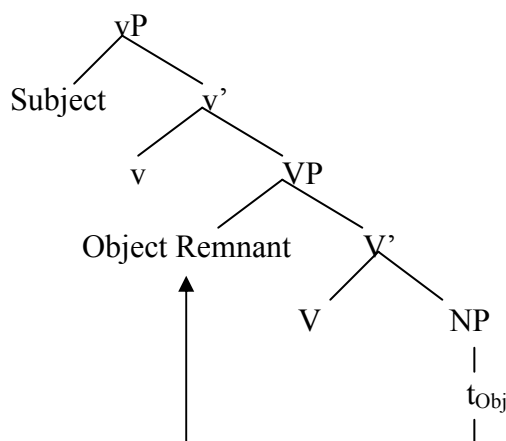

⁵⁴ Recall that in Lasnik's (1999a, a.o.) account, the split VP hypothesis (Koizumi 1995) ensured the deletion of the entire lower VP, since Agr_{OP} was situated above the lower VP.

(47)

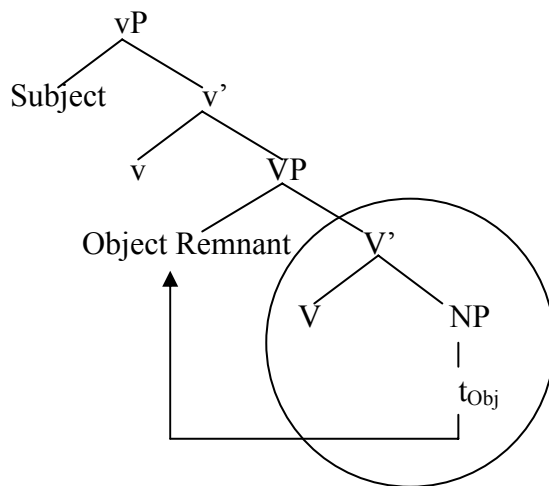

Given that in Chomsky (1995; cf. fn. 44 above) the Agreement projections were abandoned in favour of multiple specifiers, and given the definition of the EPP as a feature that causes the creation of specifiers (Chomsky 1998), not only for the subject position, the question arises as to how the EPP works in the configuration with multiple specifiers of vP , as schematised in (48) (with the potential landing site [Spec,VP]).

(48)

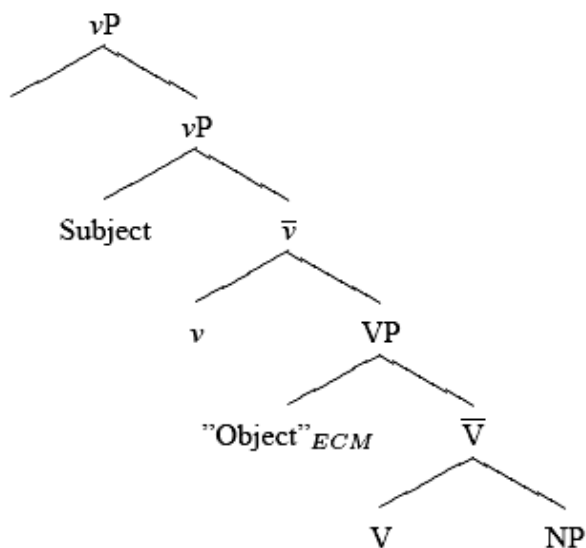

In this configuration, an EPP requirement on vP is assumed, which triggers movement to its outer specifier position (Chomsky 2001; the regular specifier being the position where the

subject is base-generated).⁵⁵ Thus, the analysis proposed in Lasnik (1995a, 1999a, a.o.) principally also holds in the configuration just described, since the EPP on *v* has exactly the desired result: if it is present on *v*, a specifier is created, serving as landing site for movement of an XP. Thus, the outer specifier could host the moved Pseudogapping remnant, rendering the deletion of the entire VP possible.

In a syntactic derivation that proceeds cyclically, in terms of phases, the EPP gains an additional dimension. One cardinal assumption that is adopted in the phase system is that checking relations are achieved via AGREE. This leaves only the EPP as trigger for movement of a DP from its base position. While this is no new claim in principle, the movement operation, and thus the relevant trigger for movement, the EPP, becomes more complex, as the derivation proceeds based on phases.

More specifically, once a phase, i.e. *v*P, or CP, is completed, i.e. all features have been checked, the phase domain is no longer accessible for syntactic material higher up in the structure. Thus, elements that are needed further in the computation must evacuate the relevant phase. In order for them to be included in subsequent operations once the lower phase is completed, they have to be situated at the phase edge, i.e. in the specifier positions of the respective phase head, as only the phase head and its specifiers are accessible and thus able to be involved in the further derivation.

Given that the EPP creates specifiers and causes movement of elements to these newly created specifiers, this configuration suggests itself for the responsibility to also bring elements to the edge of the relevant phase, to render them accessible to further computation. Again, as we will also see in later chapters of this dissertation, this is precisely what is needed for Pseudogapping: a requirement that triggers movement of the object remnant out of the VP. The question now arises, obviously, whether this double function of the EPP is needed, i.e. whether the EPP also serves as an edge feature (EF, cf. Chomsky 2001, 2005). Not surprisingly, this depends on whether one assumes that the object remnant in Pseudogapping, if it moves to the outer specifier of *v*P, has to move even further, i.e. whether it actually has to move out of the *v*P phase.

⁵⁵ I will not go into the so-called “double EPP” configuration here (Chomsky 1995: 350), where the two EPP requirements for subjects, on T and Agr_s, are conflated to yield a configuration where T needs to check the EPP twice (cf. also Mohr 2005: 17f.). However, the question at this point is whether, if the subject is taken to be base-generated in [Spec,*v*P], the generation of this particular specifier is also due to the EPP.

In a Lasnik-style approach (e.g. Lasnik 1999a, a.o.), the second movement would not be required, if the hypothesis that the EPP triggers A-movement still holds. In an A-bar-movement approach such as the one proposed in Jayaseelan (2001), however, there has to be either subsequent or direct movement to an A-bar position (see the chapter on Focus Movement for details). There is a third option, however, as we will see in what follows.

As we have seen in the discussion of how the EPP is characterised in a system without Agreement projections, and in the phase systems, the EPP has the property to create specifiers whenever they are needed to accommodate movement. In this respect, then, a distinction of specifiers that host elements that are derived via A-movement, and elements that are derived via A-bar-movement, does no longer seem to be strictly necessary.

Indeed, with regard to the outer specifier of ν P, Chomsky (2001, 2005) proposes that features that often characterise A-bar-moved elements, such as information-structural features (like topic and focus) or properties that are related to specificity or definiteness, may obtain in the outer specifier of ν P, which, in his terminology, is assigned an interpretation INT (Chomsky 2001). This interpretation INT draws on the above features, and is assigned to the outer specifier of ν P, e.g. in object shift constructions. In contrast to that, XPs that remain in their base position receive the interpretation INT', which does not incorporate any particular semantic components like the ones mentioned above.

The preliminary conclusion to be drawn from the above is thus that the outer specifier of ν P may actually host elements with A-bar-properties, which could have been moved there via A-bar-movement (as implied in Chomsky 2001, 2005). In the most minimalist structure that can be assumed for the cases that we are concerned with here, namely, Pseudogapping, ECM constructions, and particle shift, the movement could thus be the same in all cases, namely, to the outer specifier of ν P, depending on the specific presumptions we make about this specifier position.

If the properties of the relevant specifier are defined by the element that moves into this position, then, the different properties of the three constructions under discussion in this chapter, for instance with regard to their focus structure, could be accounted for. If, on the other hand, the precise nature of the specifier position is (a) due to the specific requirement triggering the movement in question, and (b) not dependent on the category that is moved

into this position (i.e. its overall characterisation in terms of A-position or A-bar-position remains unchanged), then we are back at square one. The question of whether the three constructions that are at the heart of the object shift theory, namely, Pseudogapping, ECM structures, and particle shift, have the same interpretive value, will be addressed in the next section.

4.4.3. The EPP for Objects is not uniform

As already hinted at in the previous section, the EPP is no longer treated as irrevocably triggering A-movement. While this, in principle, already opens up the possibility that Pseudogapping may also involve A-bar-movement, there seems to be further evidence for the assumption that the EPP is not uniform in character, contrary to what Lasnik (2001a) implied in his analysis.

More specifically, the object in the different object shift instances in English does not seem to display a uniform behaviour in all cases where it is assumed (and considered to be due to the EPP). If we compare the different structures where, in English, the EPP for objects is assumed, namely, particle constructions (in (49)), ECM cases (in (50)), and Pseudogapping (in (51)), we find that Pseudogapping differs from the other two cases in that there is a clear contrastivity requirement on the moved object remnant (indicated with the capitals), as shown by the ungrammaticality of the example with the unstressed pronoun remnant (51b).⁵⁶

(49) a. Mary made John out to be a fool.

b. Mary made out John to be a fool.

(50) John believes everyone [*t* not to be there yet].

(51) a. John invited Jane, and Jill did SUSAN.

b. *Jane invited him, and John did her.

c. Jane invited him/HIM, and John did HER.

⁵⁶ Howard Lasnik (p.c.) notes that there is a contrast on the subject too (only in coordinate structures, Karlos Arregui, p.c.), since the sentence in (i) below is ungrammatical.

(i) *John invited Jane and John did Susan.

This observation permits the following interpretation. The observation that contrastivity (requiring a special focus structure) seems to arise only in the ellipsis configuration, that is, not in the particle and ECM constructions, suggests that Pseudogapping should perhaps not be treated on a par with ECM and particle constructions.⁵⁷ However, this take runs counter to a rather ‘uniform’ EPP account suggested by Lasnik (2001, a.o.). In other words, the contrastivity indicates that, maybe, the EPP-feature does not play the decisive role in Pseudogapping, or does not suffice to derive Pseudogapping, and that an additional requirement is involved in the derivation. Alternatively, one could also adopt the hypothesis that the EPP is not uniform in character, moving elements irrespective of the A-movement or A-bar-movement distinction. Either way, as we will see in the following chapters, there is reason to believe that A-bar-movement could indeed be involved in Pseudogapping.

A final argument that can be brought against the object shift analysis is based on the observation that Pseudogapping also occurs in the Scandinavian languages, as indicated in chapter 2. Crucially, however, Scandinavian Pseudogapping does not seem to be amenable to either object shift analysis, that is, neither Scandinavian object shift nor English object shift.

4.5. Additional Evidence against Object Shift: Scandinavian Pseudogapping

In this section, I show that Pseudogapping data from Scandinavian, in particular, data from Icelandic casts some doubts on the object shift analysis, since it seems to pattern more with an A-bar-movement process, namely, Heavy Noun Phrase Shift.⁵⁸

Recall the Icelandic data from the data overview in chapter 2, here repeated in (52) and (53).

⁵⁷ To some extent, this contrastivity requirement is also present in the non-Pseudogapped counterpart, as pointed out by Howard Lasnik (p.c.), and indicated in (i) below.

(i) John invited Jane, and Jill invited Susan/SUSAN.

⁵⁸ In some sense, then, Scandinavian Pseudogapping patterns with the shift of indirect objects in English and with topicalisation in Serbo-Croatian. Cf. Gengel 2006f for a detailed discussion.

(52) Prepositional Complements (Icelandic):

- a. Pétur hefur lesið fleiri bækur fyrir Kara-ACC en Páll hefur _ fyrir María-ACC.
Peter has read more books for Kari than Paul has for Maria.
'Peter has read more books for Kari than Paul has for Maria.'
- b. (?)Pétur vill biða lengur eftir María en Páll vill _ eftir Jóni.
Peter will(wants-to) wait longer after Maria than Paul wants after Jóni.
'Peter will wait longer for Maria than Paul will for John.'
- c. Pétur vill leika lengur við Maríu en Páll vill _ við Jóni.
Peter wants-to play longer with Maria than Paul wants-to with John.
'Peter wants to play longer with Maria than Paul wants with John.'

(53) Dative Construction (Icelandic):

- a. María myndi skila fleiri bókum til Péturs en Páll myndi _ til Jóns.
Maria will return more books to Peter than Paul will to John.
'Maria will return more books to Peter than Paul will to John.'
- b. ??María myndi skila fleiri bókum til Péturs en Páll myndi blöðum _ til Jóns.
Maria will return more books to Peter than Paul will newspapers to John.
'Maria will return more books to Peter than Paul will newspapers to John.'
- c. **María myndi gefa Pétri fleiri bækur en Páll myndi _ blöð.
Mary will give Peter more books than Paul will newspapers.
'Mary will give Peter more books than Paul will newspapers.'
- e. ??María myndi gefa Pétri fleiri bækur en Páll myndi _ Jóni.
Mary will give Peter more books than Paul will John.
'Mary will give Peter more books than Paul will John.'

The most problematic fact for an analysis in terms of Scandinavian object shift comes from the observation that Icelandic - which has object shift of full DPs - does not allow object shift

of prepositional phrases, as shown by the ungrammatical example in (79) (Thráinsson 2001:151).

- (54) *Jón talaði [_{PP} við Maríu]_i ekki t_i.
John spoke with Mary not
'John didn't speak to Mary.'

As can be seen from the distribution of the data, however, it seems that the majority of Pseudogapping cases involve prepositional remnants in Icelandic. If one were to assume the English-type object shift, which, according to Lasnik's (1995a, 1999a) analysis, can account for prepositional remnants as well, we find that other objects that are able to undergo object shift (both in English and Scandinavian) are not found in Pseudogapping, contrary what we would expect from the English-type object shift operation.

It is a common assumption in the literature on Pseudogapping that the remnant always bears some kind of focus, which, presumably, might also hold for Pseudogapping in Icelandic. Since Heavy Noun Phrase Shift (HNPS) is also found in Icelandic, independent of Pseudogapping, the question arises whether the movement that derives Pseudogapping could be HNPS.

The *skila/ræna* verb class, which allows Pseudogapping, does not have the possibility to emphasize the indirect object by means of inversion. Hence, to focus the indirect object, a different mechanism is needed. In principle, there are two possible variants: movement of the direct object (DO) across the indirect object (IO) (as in (55)) or movement of the indirect object (IO) across the direct object (DO) (as in (56)).

- (55) DO_i [IO>t_i]

- (56) [t_i>DO] IO.

Since Icelandic displays Heavy Noun Phrase Shift (HNPS) constructions with constituents that are reasonably heavy, this phenomenon could be considered to be at play in the movement operations suggested above.

According to Ottósson (1991), however, we find an asymmetric behaviour of the objects with respect to Heavy Noun Phrase Shift, since HNPS of the direct object (DO) seems impossible, as illustrated with the anaphoric relations in (57) and (58) (cited in Holmberg and Platzack 1995: 211). More specifically, in (58), the extraposition of the heavy direct object is ungrammatical.

(57) ?Ég gaf unnustu sína_i [piltinum sem hafði beðið óþreyjufullur í mörg ár]_i.
 I gave fiancée Refl-ACC the-boy-DAT who has waited impatiently for many years.

(58) *Ég gaf unnusta sínum_i [stúlkuna sem allir strákanier voru á höttunum eftir]_i.
 I gave fiancé(masc) Refl-DAT the-girl-ACC who all boys „liked“

In sharp contrast to this, the indirect object (IO) can be moved via HNPS across the direct object (as in (57)). The slight decrease in acceptability in the case of the indirect object that has undergone HNPS could potentially be on a par with the marginally possible indirect object remnant in Icelandic Pseudogapping (as in (59) below).

(59) ??María myndi senda Pétri fleiri bækur en Páll myndi Jóni.
 Mary will send Peter more books than Paul will John.
 ‘Mary will send Peter more books than Paul will John.’

Hence, the status of the indirect object in Icelandic Pseudogapping seems to be closer to the status of indirect objects in HNPS constructions. Arguably, this is not a very strong argument for a HNPS analysis yet, but we will see that the picture becomes clearer with direct objects.

As shown by Ottósson’s examples, repeated as (60), the direct object does not undergo HNPS past the indirect object. This, at first sight, is an exact replication of the behaviour of direct objects in a Scandinavian object shift approach, as illustrated in (61) (Thráinsson 2001:168).

(60) a. ?Ég gaf unnustu sína_i [piltinum sem hafði beðið óþreyjufullur í mörg ár]_i.
 I gave fiancée Refl-ACC the-boy-DAT who has waited impatiently for many years.
 b. *Ég gaf unnusta sínum_i [stúlkuna sem allir strákanier voru á höttunum eftir]_i.
 I gave fiancé(masc) Refl-DAT the-girl-ACC who all boys „liked“

- (61) a. Ég skilaði ekki manningum bókinni.
 I returned not man-the-DAT book-the-DAT
- b. Ég skilaði manningum_i ekki t_i bókinni.
 I returned man-the-DAT not book-the-DAT
- c. Ég skilaði manningum_i bókinni_j ekki t_i t_j
 I returned the-man-DAT book-the-DAT not
- d. *Ég skilaði bókinni_j ekki manningum t_j.
 I returned book-the-DAT not man-the-DAT
 ‘I didn’t return the book to the man.’

However, again we find that the pattern diverges from object shift, since object shift can move a direct object in a simple transitive construction without problems (cf. (62), Thráinsson 2001:164), whereas Pseudogapping is completely ungrammatical with direct object remnants, as illustrated in (63) and (64) below.

- (62) Jón las bókina_i ekki t_i.
 John read book-the-ACC not
 ‘John didn’t read the book.’

- (63) **María myndi senda Pétri fleiri bækur en Páll myndi blöð.
 Mary will send Peter more books than Paul will newspapers.
 ‘Mary will send Peter more books than Paul will newspapers.’

- (64) *Pétur hefur lesið fleiri bækur en María hefur dagblöð.
 Peter has read more books than Maria has newspapers.
 ‘Peter has read more books than Maria has newspapers.’

If Ottósson’s observations are true, then HNPS of direct objects (DO) across indirect objects (IO) seems to be blocked. The Scrambling alternative that he proposed to explain the Icelandic inversion examples, however, is rejected by Holmberg & Platzack (1995: 213) on the grounds of the comparison to German (where two base-generated structures for inverted and non-inverted structures are assumed as well).

On the basis of the data provided above, we can draw the conclusion that an HNPS approach to Icelandic Pseudogapping gives a better account of the empirical data. As Takahashi (2003a, b, 2004a) points out, PPs are able to undergo Heavy NP Shift, too, which is a further argument in favour of an Heavy NP Shift approach.

4.6. Conclusion

In this chapter, I have provided a detailed discussion of the implementation of the A-movement approach to Pseudogapping in terms of the EPP. I concluded that the puzzle that remains to be solved is the question of why we obtain different interpretive effects in the structures where overt object shift due to the EPP is assumed. On the basis of these semantic issues, and the fact that object shift does not seem to be able to account for all remnants, according to Takahashi's (2003a, b, 2004a) account, I suggest that the movement in Pseudogapping be viewed as A-bar-movement, to accommodate the focus effects. Before I show how A-bar-movement can be implemented and defined such that it covers a wide range of elliptical structures, I have to discuss a separate group of arguments that have been adduced in favour of A-movement in Pseudogapping, namely, Binding effects.

5. Binding Effects and A-bar-Movement in Pseudogapping

This chapter is intended to cover the arguments that are taken to be decisive for the differentiation between A-movement and A-bar-movement in Pseudogapping, namely, the binding effects that are found with the respective types of remnants. I will discuss these arguments with respect to their supportive value for an A-movement account, and will then illustrate that, unfortunately, most of these arguments are not as straightforward as they seem at first glance. On the basis of the evidence given below, I will thus conclude that the binding effects could also advocate a Pseudogapping analysis in terms of A-bar-movement.

The chapter is organised as follows. In the first part, I will consider the argument that could be regarded as irrefutable argument for an A-movement derivation of Pseudogapping, namely, the binding effects that arise between the first and the second remnant in Pseudogapping. I will then move on to the discussion of the more controversial observations in the context of reconstruction. Building on the evidence from Binding Theory, I will subsequently address two other issues that do not bear directly on binding but provide a good measure of support for the conclusions reached with regard to binding effects. The first of the two issues is the licensing of parasitic gaps in Pseudogapping, and the second concerns the behaviour of Pseudogapping with respect to control. Finally, I will show how these findings pattern with the approach suggested in Takahashi (2003a, b, 2004a) that there are Pseudogapping remnants which are necessarily derived via A-bar-movement.

5.1. Binding Relations between remnants in Pseudogapping

In the previous chapter (chapter 4), I have shown that the assumption of object shift being the relevant movement in Pseudogapping is not uncontroversial. Nonetheless, there is one strong piece of evidence for the claim that A-movement is responsible for the derivation of Pseudogapping, as we will see in the following.

Baltin (2003: 241) argues that the binding relations between remnants in Pseudogapping speak clearly against an analysis in terms of A-bar-movement. He bases his claim on the following assumption: if binding of anaphors does only take place from A-positions, an anaphor in the second remnant of a Pseudogapping construction could not be bound if the first remnant were in an A-bar-position.

To illustrate the problem, let us start with the sentence in (1), where the binding relations with the reciprocal element are satisfied (Baltin 2003: 241, his (30)).

(1) Although I wouldn't introduce these people to Tom and Sally, I would _ those people to each other.

With prepositional datives in general, the binding patterns are such that the direct object can bind into the prepositional dative, but not vice versa (Baltin 2000: 28; Larson 1988). This is illustrated in (2) (Baltin 2000: 28, his (59)).

(2) a. I introduced them to each other.
b. *I introduced each other to them.

In Pseudogapping, however, the binding relations from (1) above prove to be problematic, which is shown in (3b) below (Baltin 2000: 30). If the indirect object contains an anaphor which is bound by the direct object, Pseudogapping is impossible once the indirect object remains as the only remnant. In other words, it is not possible that an ellipsis remnant contains an anaphor with the antecedent within the VP (Baltin 2003: 229).⁵⁹

(3) a. Although I wouldn't introduce them to Tom and Sally, I would introduce them to each other.
b. *Although I wouldn't introduce them to Tom and Sally, I would _ to each other.

If both remnants co-occur, however, the first remnant can bind an anaphor in the second remnant, as in (4) (Baltin 2000: 32).

⁵⁹ Baltin (2003: 229) attributes this observation to Collins (1996).

(4) Although I wouldn't introduce these people to Tom and Sally, I would _ those people to each other.

Baltin (2003: 229) takes this to be evidence that Principle A of the Binding Theory cannot apply at every level of the derivation, as had been suggested in Belletti and Rizzi (1988). If this were the case, the direct object could bind the anaphor inside the prepositional complement. From the evidence of data such as (3), Baltin (2003: 230, his (28)) concludes that binding can only apply after the Pseudogapping remnants have left the VP. Thus, Baltin (2003: 216) argues that Principle A applies either at LF, or, following Chomsky (2000, 2001), when each Phase is completed, i.e. CP or ν P.

Consider in this context the example of ECM subjects (which are taken to behave like regular objects) and Lasnik's (2001a) account of the high behaviour they exhibit. Here too, the question arises where the binding principle invoked in (5) (Lasnik 2001a: 103f., his (1)) actually applies.

(5) *Condition A Satisfaction*

The DA proved [two men to have been at the scene of the crime] during each other's trials.

Lasnik (2001a: 105) maintains that Binding has to take place in the syntax (based on Chomsky 1981, and Barss 1986). In the examples in (6) and (7) below (Lasnik 2001a: 105, his (13) and (14)), the antecedent in the position of the matrix subject can actually license an anaphor in the embedded [Spec,CP], as in (6).

(6) John_i wonders which picture of himself_i Mary showed to Susan.

(7) *John_i wonders who showed which picture of himself_i to Susan.

In this light, it is curious that (7) should be ungrammatical, unlike (6), if the second *wh*-phrase moved to the embedded [Spec,CP] at LF, and anaphors could be licensed in their LF positions. On the basis of these assumptions, the LF configuration between *himself* and the antecedent is exactly the same in both (6) and (7). Thus, Lasnik (2001a: 105) concludes that anaphors must be licensed prior to the LF level, i.e. already in the syntax.

Baltin (2003: 232f.) also shows that Dutch Scrambling, which he takes to be the movement involved in Pseudogapping, based on Johnson's (1996a) account, actually obeys the binding constraints that can be found in Pseudogapping. Neither English Pseudogapping ((8b), cf. the discussion above) nor Dutch Scrambling permit movement of a remnant or anaphor out of the VP if the antecedent is still contained in the VP (9).

(8) a. Although I wouldn't introduce them to Tom and Sally, I would introduce them to each other.

b. *Although I wouldn't introduce them to Tom and Sally, I would _ to each other.

(9) *... dat Jan aan [aan elkaar;_i] geprobeerd heeft de kinderen_i voor te stellen t_i t_j
 ... that John to each other tried had the kids PRT to introduce.

As a last point, Baltin (2003: 233) notes that, as already mentioned in the discussion above, an anaphor as English dative Pseudogapping remnant is grammatical if the direct object antecedent precedes it in overt structure (10), which is also true for Dutch Scrambling (in (11), both (10) and (11) from Baltin 2003: 233).

(10) Although I wouldn't introduce these people to Tom and Sally, I would _ those people to each other.

(11) ...dat Jan de kinderen_i [aan elkaar_i]; geprobeerd heeft voor te stellen t_i t_j
 ...that John the kids to each.other tried has PRT to introduce.

The argument that the binding relations between the two remnants have to be satisfied in overt structure poses a serious problem for any A-bar movement theory of Pseudogapping. Since A-bar movement is generally taken to not influence the binding relations between arguments (at least not to the extent A-movement does), the ungrammaticality of the above examples would be unexpected under an A-bar movement account. If the A-bar-moved element reconstructed (obligatorily, cf. the argument on reconstruction below), then the binding relations of the two remnants could be satisfied at LF, which should allow a proper interpretation of the Pseudogapping examples in question. If, however, as Baltin argues, the remnants in Pseudogapping are A-moved, and A-movement does not reconstruct, the necessary binding relations would have to be established in overt syntax.

On the face of it, this argument does not seem easy to refute. However, I would like to point out two possible weak points of the above argumentation. A first doubt concerning a general impossibility to reconstruct arguments in Pseudogapping comes from data from Sauerland (Sauerland 1998: 144, quoted and adapted in Takahashi 2004a: 6, his (20)), which actually show reconstruction effects, rendering the sentence in (12a) ungrammatical (cf. the more detailed discussion in the section on reconstruction below).

- (12) a. *While some granted/told him_i everything, others did ~~grant/tell him_i~~ only the story that John_i had met aliens.
b. While some granted/told him_i everything, others did ~~grant/tell him_i~~ only the story that John_i had evidence for.

While this, as discussed below, is a curious fact, but presumably does not carry enough weight to challenge the A-movement derivation for the example given in Baltin (2003) in principle, a second reason to doubt his analysis of the binding facts above lies in the very choice of his example. Consider the ungrammaticality of (13) (Baltin (2003: 230, his (28)), which Baltin takes to be due to a failure to comply with the relevant binding relations.

- (13) *Although I wouldn't introduce them to Tom and Sally, I would _ to each other.

However, in his previous work, Baltin (2000: 16) points out that while reflexives inside remnants are acceptable in Pseudogapping, "... according to my informants, it seems that reflexives and reciprocals as remnants are unacceptable when they cannot receive an analysis as logophors, i.e. when they are the arguments themselves" (ibid.). This is shown in the contrast between reflexives within remnants (14) (Baltin 2000: 16, his (33)), and reflexives (15a) and reciprocals (15b) (ibid., his (34)) as remnants themselves.

- (14) Although John didn't take pictures of Sally, he did _ pictures of himself.

- (15) a. *Although John doesn't like Sally, he does _ himself.
b. *Although they don't like Tom and Sally, they do _ each other.⁶⁰

⁶⁰ Note though that the sentence in (i) below with the preposition seems to be acceptable (Howard Lasnik, p.c.).

(i) Although John doesn't talk to Sally, he does _ to himself.

In one sense, the situation in the example with the prepositional dative (in 13) and the examples in (15) seems to be similar, since in both cases, the remnant has been A-moved out of the VP. However, while (13) could be ungrammatical simply for lack of a proper antecedent in overt structure, the problem with the sentences in (15) seems to be more complex. Here, as Baltin pointed out (Baltin 2000: 16), the remnants cannot be considered as logophors, and as such as exempt from the rules of the binding theory. Principally, though, there seems to be no obvious difference between the respective movement that the remnant has undergone in both cases. While this A-movement could potentially be ungrammatical because it crosses a direct object in (13), this concern does not apply to the examples in (15). The question thus arises of what renders these examples ungrammatical – if the movement is A-movement, as assumed for a sentence such as (16), the question is why the anaphor cannot be bound in the higher position, which, according to Baltin's (2000) account, is definitely an A-position.

(16) Although John doesn't like Sally, he does _ Peter.

One way to overcome this dilemma is to assume that the anaphor can only be bound by the subject once it is in its base position again at LF – which would amount to saying that in the example in (15a), *himself* moved to a position from where it has to be reconstructed. Given that the movement is taken to be A-movement, this should not be possible, since otherwise, the subject too should be able to reconstruct, which, clearly, would be an unwelcome result on standard assumptions about A-movement. Supposedly, then, the upper A-position differs from the lower, base-generated position in that binding is not possible in this position.

This conclusion, in turn, is overthrown by the sentence in (10) above, here repeated as (17).

(17) Although I wouldn't introduce these people to Tom and Sally, I would _ those people to each other.

On the account given in Baltin (2000, 2003), there should have been two instances of A-movement, of *those people* and *each other*. If this is true, though, then the second remnant should be in a higher A-position – at least not in its base-generated position.

Clearly, the problem outlined above merits closer inspection in future research. At present, however, I can only conclude that the data discussed in this section support the A-movement approach to a great extent. Unfortunately, though, examples such as (15) raise a lot more questions than an A-movement account such as the one presented in Baltin (2000, 2003) can actually answer.

5.2. Reconstruction Effects

As already mentioned in section 5.1. above, there are unexpected reconstruction effects in Pseudogapping, which Takahashi (2004a) considers to be problematic for a Pseudogapping analysis solely in terms of A-movement.

To illustrate the problem, consider first the asymmetry between adjuncts and complements in (18) (Takahashi 2004a, examples taken from Lebeaux 1988: 146).⁶¹

- (18) a. *[Whose claim that John_i is nice]₁ did he_i believe t₁?
b. [Which story that John_i wrote]₁ did he_i like t₁?

In (18a), the argument (the sentential complement of *claim*) must be reconstructed in A-bar movement contexts, which is not possible and results in a violation of Principle C. The sentence in (18b) is fine, since adjunct relative clauses (*that John wrote*) do not have to be obligatorily reconstructed.

The picture is different in an A-movement setting. In (19) (Takahashi 2004a: 6, his (19), from Chomsky 1993: 37), the argument (*the claim that John_i was asleep*) “does not show an obligatory reconstruction effect in A-movement” (Takahashi 2004a: 6).

- (19) [The claim that John_i was asleep]₁ seems to him_i [t₁ to be correct].

In a Pseudogapping analysis based on A-movement, the prediction would be that there is no obligatory reconstruction effect with arguments. However, data from Sauerland (1998)

⁶¹ As we will see below, however, the argumentation put forward in Takahashi (2004) is not entirely straightforward because the data receive different grammaticality judgements.

suggest that this expectation is not met, as illustrated in the examples in (20) (Sauerland 1998: 144, adapted in Takahashi 2004a: 6, his (20)), which actually do show reconstruction effects.

- (20) a. *While some granted/told him_i everything, others did ~~grant/tell him_i~~ only the story that John_i had met aliens.
b. While some granted/told him_i everything, others did ~~grant/tell him_i~~ only the story that John_i had evidence for.

Takahashi (2004a: 6) thus concludes on the basis of the ungrammaticality of (20a), which is due to the obligatory reconstruction requirement, that the movement involved in Pseudogapping is not A-movement, or, minimally, that A-movement cannot account for all instances of Pseudogapping.

However, Lasnik (p.c.) judges (20a) to be grammatical, which sheds considerable doubt on Takahashi's (2004) conclusion. Lasnik himself (Lasnik 2004) also treats instances of reconstruction. He shows that the assumption that "[t]otal' reconstruction (i.e., for scope) is generally not available with A-chains" (Lasnik 2004, his (140)) is not necessarily true in some cases, such as the one with indefinite subjects in a non-negated clause given in (21) below (Lasnik 2004, his (142)).

(21) Someone is likely to solve the problem.

The table below in (22) illustrates once again how Pseudogapping patterns with respect to argument movement.

(22)

General	Reconstruction?
A-bar movement of argument	obligatory reconstruction
A-bar movement of adjunct	no reconstruction necessary
A-movement of argument	no reconstruction necessary
Pseudogapping	Reconstruction?
Object Shift of argument	obligatory reconstruction

On the basis of this table, it seems that Pseudogapping, with respect to the cases discussed above in (20), rather patterns with A-bar-movement than with A-movement.

In the next two sections, I will discuss arguments that are less tightly linked to the domain of binding theory, but support the results of the binding effects found in Pseudogapping.

5.3. Parasitic Gap Licensing in Pseudogapping

Baltin's (2003) first argument for an A-movement approach is that A-bar-movement, unlike A-movement, usually licenses parasitic gaps. However, Pseudogapping fails to comply with this diagnostic for A-bar-movement, as shown in (23) (Baltin 2003: 241, his (51)).

(23) *Although John didn't kiss MARY_i without looking at e_i, he did SALLY_j without looking at e_j.

This is quite unexpected for an account in terms of A-bar-movement, such as, for instance, focus movement, since [Spec,FocP] is standardly assumed to be an A-bar-position. Moreover, [Spec,FocP] in languages other than English licenses parasitic gaps ([Spec,FocP] being standardly considered to be an A-bar-position), for instance, in Hungarian (as noted in Horvath 1999). In this light, the observation that Pseudogapping does not license parasitic gaps, as shown in (62), considerably weakens the hypothesis that the Pseudogapping remnant moves to an A-bar-position such as [Spec,FocP].

Takahashi (2003b) shows that evidence from indirect objects in double object constructions (in (24)) confirms the A-movement hypothesis. Thus, at first sight, the prediction that Pseudogapping does not license parasitic gaps at all seems to be borne out, since, just as in constructions with a single ('indirect') object in (23) above, parasitic gap licensing is not possible either with indirect object remnants in double object constructions, which is illustrated in (24) (taken from Takahashi 2003b).

- (24) a. *Although John didn't give the tall boy a book, he did [the short boy]_i [without meeting e₁].
 b. *Although John didn't give the tall boy a book, he did [without meeting e₁] [the short boy]_i.

Interestingly, though, in Takahashi's (2004a) account, the ungrammaticality in (24a) and (24b) does not have a common source. In (24a), Takahashi assumes (Takahashi 2004a: 11) that the remnant *the short boy* cannot undergo Heavy NP Shift, which is why a parasitic gap is not licensed, and the remnant cannot be placed after the adjunct. In (24b), however, the fact that there is a parasitic gap renders the sentence ungrammatical, since, according to Takahashi (2004a: 11), the movement involved in (24b) is object shift, which does not license parasitic gaps (cf. also the discussion of the contrast between the examples in (25) and (26) below).⁶²

However, Takahashi (2003a, b, 2004a) points out that parasitic gaps are actually possible in Pseudogapping, with direct object remnants in double object constructions, as in (25a) (Takahashi 2003b), direct object remnants in dative constructions (25b) (Takahashi 2003a) and with objects of simple transitive clauses, as in (26) (Takahashi 2004a).

⁶² Recall that Takahashi (2004a: 6) assumes that the relevant object shift movement in English Pseudogapping patterns with the Scandinavian variant of object shift, thus patterning with A-movement. He (ibid., his (21)) cites Icelandic data from Jónsson (1996: 72) which illustrate that object shift in Scandinavian does not license parasitic gaps (i).

(i) *Þu setur [Þetta blað]_i ekki t₁ á borðið [án þess að lesa e₁]
 you put this paper not on the table without reading
 'You didn't put this book on the table without reading.'

(25) a. Although John didn't give the boy a short paper, he did [without reading e_1] [a long paper]_i.

b. Although John didn't give a short paper to Mary, he did [without reading e_1] [a long paper]_i.

(26) Although John didn't file a recent article about HNPS, he did [without reading e_1] [a recent article about Object Shift]_i.

(27) *Although John didn't kiss Mary, he did Sally_i without looking at e_i .

Takahashi (2004a: 10) suggests that the difference in acceptability between a sentence such as in (26) above and the one in (27) (which is Takahashi's version of (23) above, Takahashi 2004a: 10) is due to the positioning of the remnant in relation to the adjunct phrase. In (27), the remnant precedes the adjunct, which it doesn't do in (26). The particular configuration in (27) is derived by leftward A-movement, i.e., object shift, which, according to Takahashi, also explains the lack of licensing parasitic gaps.

Note, however, that this argument for A-movement can only be partly confirmed, since one would also expect that anti-reconstruction effects related to Principle C (as in (28) below, taken from Takahashi 2004a: 6, his (19), taken from Chomsky 1993: 37) also obtain in Pseudogapping, that is, that Pseudogapping does not show condition C effects (cf. e.g. Barss 2001: 689ff. on Condition C and anti-reconstruction effects).

(28) [The claim that John_i was asleep]_i seems to him_i [t_i to be correct].

As Takahashi (2004a: 10) points out, though, configurations in which this prediction might be tested are very difficult to find.⁶³

As a final note, note that Baltin (2003), as mentioned above, argues that Johnson's (1996a) account of Pseudogapping in terms of Dutch Scrambling is correct. As Baltin himself concedes in a footnote (Baltin 2003: 241, fn. 14), however, his own view that if Dutch

⁶³ He puts it as follows (Takahashi 2004a: 10, fn. 9): "Unfortunately, I have not found a configuration in which this prediction can be examined. But, see the discussion on the parasitic gap licensing, which is based on the same logic."

Scrambling accounts for Pseudogapping, it must be A-movement, is not warranted any longer if Dutch Scrambling does license parasitic gaps, which it does, as illustrated in (29) (Baltin 2003: 240, his (49)).

(29) dat John Marie_i zonder e_i ann te kijken t_i gekust heeft.

That John Mary without on to look kissed has.

That John kissed Mary without looking at her.

As Neeleman (1994: 400-404) points out, though, A-positions in Dutch can also license parasitic gaps.

While the evidence from direct objects in Pseudogapping, paradoxically enough, with the occurrence of parasitic gaps, might thus support the claim that Dutch Scrambling is A-movement (or at least, has A-properties, if one considers parasitic gap licensing a potential property of A-movement), it still does not account for the observation that Pseudogapping does not seem to license parasitic gaps in all cases, especially not in the cases with indirect object remnants, where the A-movement account seems to be the most natural explanation (cf. Takahashi 2003a, b, 2004a).

Building on the evidence described above, and summarised in the table below (30), I will thus conclude that the parasitic gap data challenge the view that *all* instances of Pseudogapping are derived via A-bar-movement, but that the effects found with parasitic gaps in Pseudogapping do not provide sufficient evidence for an analysis of Pseudogapping solely in terms of A-movement either.

(30)

Type of Pseudogapping Remnant	Parasitic Gap licensed?
object of transitive clause	yes (Takahashi)
object of transitive clause	no (Baltin/Takahashi)
direct object in double object construction	yes (Takahashi)
indirect object in double object construction	no (Takahashi)

Type of Pseudogapping Remnant	Parasitic Gap licensed?
direct object in dative constructions	yes (Takahashi)
indirect object PP in dative construction	no (<i>PPs never license parasitic gaps</i>) ⁶⁴

Thus, the evidence provided on the basis of parasitic gaps seems to lean both ways. For object remnants in transitive clauses, the situation is such that only one group of remnants does not license parasitic gaps, namely those that occur as indirect objects in double object constructions. The indirect objects in double object constructions do not license parasitic gaps either. While this seems to indicate that there is A-movement involved in these particular configurations (a point to which I will return in the discussion on the syntactic structure of Pseudogapping), there are two general arguments that speak against parasitic gaps as a crucial tool for the decision between an A-movement or A-bar-movement account for Pseudogapping.

First of all, it is debatable whether one should base an entire argument on evidence from parasitic gaps, since they seem to be subject to a great variance in speaker judgements in general.

Secondly, if this claim is maintained, then the inconsistency of the occurrence of parasitic gaps in Pseudogapping, as clearly indicated in the table above, cannot be accounted for. On the whole, it seems that in fact, not only the other half of the remnants, i.e. the direct objects, do license parasitic gaps, but the remnants that seem to occur most often in Pseudogapping, the prepositional remnants (in dative constructions, Levin 1986), never license parasitic gaps. Hence, they are potentially not amenable to be used as evidence for either account.

Moreover, given the observation that the dative construction is used if the speaker wishes to emphasise the indirect argument in a particular way (as opposed to the information-structurally less marked double object variant; cf. Levin 2005 and the references therein), the abundance of prepositional remnants in Pseudogapping could point to an analysis in terms of A-bar-movement, despite the lack of parasitic gaps in this particular configuration.

⁶⁴ As mentioned in Takahashi (2003a, b, 2004a).

5.4. Control in Pseudogapping

One argument that has been adduced in favour of an A-movement account of Pseudogapping (Baltin (2000: 14)) concerns the observation that control infinitives cannot be Pseudogapping remnants (31) (Baltin 2000: 14, his (30)), while infinitives with arbitrary control actually can (32) (Baltin 2000: 15, his (31)).

(31) a. *Although I didn't try to visit Sally, I did _ to visit Susan.

b. *Although he doesn't want to give a lecture, he does _ to visit.

(32) a. Although it isn't permitted to smoke in the theater, it is permitted to smoke in the lobby.

b. Although it isn't permitted to smoke in the theater, it is _ to smoke in the lobby.

On Baltin's interpretation of these data (cf. fn. 7) the difference between the two kinds of PRO involved in these examples also holds for their behaviour with respect to A-movement, which, according to him, provides further evidence for an A-movement account of Pseudogapping. His argument is as follows.

In sentences such as (31), PRO is controlled, and thus treated as an anaphor, which needs to be bound in its domain. The arbitrary PRO of (32) is a pronoun, and thus free.

Moreover, in (33) (Baltin 2000: 15, his (32)), the *for*-infinitive in (33a) can undergo A-movement. This is not true for (33b), which illustrates the same infinitive construction with a controlled PRO. While a construction with a controlled PRO cannot be A-moved, (33c), in turn, shows that once the subject is arbitrary, A-movement is possible again.

(33) a. For John to leave early would be preferred by everyone.

b. *To leave early would be preferred by everyone.

c. To smoke in the lobby seems to be permitted.

Thus, Baltin (2000: 15) concludes that this pattern lends further support to the claim that Pseudogapping remnants undergo A-movement.

However, the argument provided by Baltin loses much of its appeal once we treat Pseudogapping cases with multiple remnants. As Baltin (2000: 22) himself points out, obligatorily controlled infinitives and bound anaphors can actually be Pseudogapping remnants, but only second Pseudogapping remnants. This is illustrated in the contrast between (34) and (35) below (Baltin 2000: 33, his (66) and (68)).

(34) *Although I couldn't persuade him to vote for Bill Clinton, I could _ to vote for Hillary Clinton.

(35) Although I couldn't persuade Max to vote for Bill Clinton, I could _ Susan to vote for Hillary Clinton.

How the observation that these specific constructions do occur as Pseudogapping remnants could be reconciled with the hypothesis that none of these items, as claimed previously, can undergo A-movement, is not entirely clear to me. Presumably, the presence of these elements in Pseudogapping should be viewed more as a matter of control than actual A-movement, since, as implied in the discussion above, the configuration with these elements as second remnants is only possible if “the controller or the antecedent is the first remnant” (Baltin 2000: 22).⁶⁵

5.5. Binding Relations and A-bar-Movement

In this section, I will provide some arguments that the binding relations discussed in the previous sections could also be captured with an A-bar-movement account of Pseudogapping. Recall from the discussion of binding in A-movement that one of the main arguments

⁶⁵ Baltin (2000: 22) describes this as “amnesty” on the restriction of remnants in the two cases mentioned above, but notes that “this restriction cannot be amnestied for predication” (i.e. predicative remnants are still ruled out as Pseudogapping remnants, even if they occur as second remnants), as shown in (i) and (ii) for small clause predicates and ECM infinitives, respectively (Baltin 2000: 33f.).

(i) *Although I don't consider Susan malicious, I do _ Martha dishonest.

(ii) *Although I don't consider Susan to be malicious, I do _ Martha to be dishonest.

To my mind, this somehow makes an analysis of the failure of predicates as Pseudogapping remnants as a failure to comply with Binding Theory and A-movement rather doubtful. To some extent, this is acknowledged by Baltin (2000: 33), who notes that the restrictions on the occurrence of anaphors and controlled infinitives as Pseudogapping remnants cannot be captured with restrictions on their movement.

consisted in the assumption that the binding relations between the first and second remnant in Pseudogapping could only be established via A-movement. As mentioned in the discussion on this topic, the data that have been adduced to support this argument are not entirely straightforward. While this awaits future research, binding relations could, however, in principle also be established via A-bar-movement, as illustrated in the example from German in (36) (Fanselow 1995).

(36) ... weil er_i sich_i [anstatt PRO_i pg_i um die Studenten zu kümmern] t_i allein mit dem
 because he himself instead PRO to the-students to look-after alone with the
 Buch beschäftigte
 book occupied

‘... because he occupied himself with the book instead of looking after the students’

Here, the anaphor is bound in an A-bar position or after reconstruction (Howard Lasnik, p.c.), since A-bar-movement has taken place. Winnie Lechner (p.c.) points out that this implies that binding and the licensing of parasitic gaps can be established both either in A-positions or A-bar-positions.

While this might not be helpful with the binding relations between the first and second remnants, the question that arises from examples such as (36) above is whether the distinction between binding relations that obtain after A-movement and those that obtain after A-bar-movement is as settled as it generally seems to be (cf. also Barss 2001 for discussion). In any case, these observations make some (if only small) room for the possibility that A-bar-movement can account for facts that have previously been attributed only to A-movement.

Another instance where this rigid distinction between A-movement and A-bar-movement does not seem to go through in a straightforward manner concerns a standard diagnostic for A-bar-movement also relevant for Pseudogapping, the licensing of parasitic gaps. As mentioned above, there is reason to believe that in Dutch, A-movement is actually able to license parasitic gaps (cf. also the discussion in Baltin 2000). If this were true, the evidence for A-movement in Pseudogapping in terms of the failure to license parasitic gaps is weakened even further.

Thus, on the whole, the arguments for A-movement that have been adduced in the literature are not conclusive, and could also be considered to support the claim that the movement involved in Pseudogapping is actually A-bar-movement rather than A-movement. This hypothesis, in turn, is strengthened with the distributional particularities of the Pseudogapping remnants, since most of the remnants, as we will see in the following section, are actually amenable to a structural derivation in terms of A-bar-movement.

5.6. Pseudogapping Remnants derived via A-bar-Movement

As already mentioned in the discussion about object shift in the previous sections of this chapter, there seem to be Pseudogapping remnants that cannot be derived via A-movement. The following table in (37), which is based on Takahashi (2004a), shows that the options of Heavy NP Shift and object shift are evenly distributed, i.e. for almost every Pseudogapping remnant with the exception of indirect object remnants in double objects, an account in terms of A-bar-movement (Heavy NP Shift in Takahashi's approach) can be assumed.

(37)

Type of Remnant	Heavy NP Shift	Object Shift
object in transitive clauses (single remnant)	✓	✓
direct object remnant in double object constructions	✓	*
direct object remnant in dative constructions	✓	✓
indirect object in double object constructions	*	✓
indirect object in dative constructions (the PP)	✓	*
two remnants in double object constructions	*twice ✓once (direct object)	✓ ✓once (indirect object)
two remnants in dative constructions (the PP)	*twice ✓once (indirect object)	*twice ✓once (direct object)

5.6.1. Deriving direct object remnants in double object constructions

As we have seen above in the section on A-movement, the problem of deriving direct object remnants with object shift hinges on the assumption that ellipsis targets constituents, as shown in (38), where a non-constituent structure is elided.

(38) a. Although he wouldn't give Bill the book, he would the paper.

b. [TP he₁ would [VP t₁ [AgrP₂ Bill₂ [VP₂ t₂ [AgrP₃ the paper₃ [~~VP₃ give t₃]]]]]]]]~~

As mentioned in the previous chapter, Takahashi (2004a) adduces evidence from the Scandinavian languages to show that direct objects cannot be shifted across indirect objects, since English, in this respect, patterns with Icelandic (and Danish), where only indirect objects can be shifted, as illustrated in the Icelandic example in (39) (quoted from Anagnostopoulou 2002: 7).⁶⁶

(39) a. Ég skilaði manninum ekki bókinni.

I returned the-man-DAT not the-book-DAT

b. *Ég skilaði bókinni ekki manninum.

I returned the-book-DAT not the-man-DAT

'I did not return the book to the man.'

This situation is reflected in the passive construction, where Icelandic and Danish only permit the indirect object to be the subject of a passive (40) (Icelandic; Anagnostopoulou 2002: 8), a situation that is replicated in (American) English (41).

(40) a. Jóni var skilað bókunum.

John-DAT was returned the-books-DAT

b. *Bókunum var skilað Jóni.

the-books-DAT was returned John-DAT

'The book was returned to John.'

⁶⁶ Takahashi (2003a) notes that (98b) is grammatical with certain verb classes. The underlying order of objects in these cases is direct object > indirect object, however (cf. Holmberg and Platzack 1995).

- (41) a. Mary was sent a letter.
b. ?*A letter was sent Mary.

Since English does not allow the passivisation of the direct object, the direct object should not be able to undergo Object Shift, hence, an analysis of direct object remnants in Pseudogapping in terms of Object Shift is ruled out, and an analysis in terms of A-bar-movement is advocated.

As we have seen in the table in (37), however, the object remnant in a transitive construction could, in principle, undergo either object shift or Heavy NP Shift, as Takahashi (2004a) concedes on the basis of the behaviour of the direct object in double object constructions and dative constructions. In this context, too, there are two points that need to be mentioned.

Firstly, in Lasnik's (1995a, 1999a) account of EPP-driven object shift, the distinction between the types of objects is not crucial, since all remnants could be subject to the object movement he proposes. However, according to Takahashi (2004a), Lasnik leaves open (and does explicitly so in Lasnik 1999a) the possibility of deriving the direct object remnant also via Heavy NP Shift, which is reflected in Takahashi's (2003a, b, 2004a) analysis described above (ruling out the object shift derivation due to the pattern found with Scandinavian object shift).

Secondly, on the basis of the binding effects found in Pseudogapping, the conclusion imposes itself that there are instances of object remnants in transitive constructions that are derived via object shift, and object remnants that seemed to have undergone A-bar-movement.

As we will see in the following sections, however, this ambiguity with respect to the derivation of the remnant is highly restricted in Pseudogapping cases with more than one remnant.

5.6.2. Deriving indirect object remnant PPs in dative constructions

For the indirect object remnant in dative constructions, i.e. the PP, the movement type in question is limited to HNPS, since Heavy NP Shift is possible with prepositional phrases (cf.

(43) and (44b), whereas Object Shift is not (cf. (44c) and the Icelandic examples in (45); from Thráinsson 2001: 151).

(43) a. Sue gave the book t_1 on Friday [to John]₁. (Pesetsky 1995: 261)

b. We gave t_1 to John on Friday [a brand-new toy]₁. (Pesetsky 1995: 249)

(44) a. Although he wouldn't give the book to Bill, he would ~~give the book~~ to Susan.

b. ... he₁ would [_{vP} [_{vP} t_1 give the book t_2] to Susan₂]



HNPS

c. *... he₁ would [_{XP} to Susan₂ [_{vP} t_1 give the book t_2]]

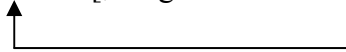

Object Shift

(45) a. Jón talaði ekki [_{PP} við Maríu].

John spoke not to Mary

b. *Jón talaði [_{PP} við Maríu]₁ ekki t_1 .

John spoke to Mary not

‘John didn’t speak to Mary.’

The two cases investigated above, the direct object remnants and the PPs, show that in these instances, in Takahashi’s (2003a, b, 2004a) analysis, only Heavy NP Shift (or, A-bar-movement) seems possible. This is summarised in the table below (46). While these two cases are quite straightforward, we will see in the following that the derivation of the other types of remnants are, again, open to a certain kind of optionality, according to the context they occur in.

(46)

Type of Remnant	Heavy NP Shift	Object Shift
direct object remnant in double object constructions	✓	*
indirect object remnant in dative constructions (the PP)	✓	*

5.6.3. Deriving Pseudogapping with multiple remnants in double object constructions

For the sentence in (47a) below (Takahashi 2003b; omitting the operator structure of the comparative), there are two possible derivations. Since the multiple application of Heavy Noun Phrase Shift is not permitted on independent grounds, there is either the eclectic approach (47b), involving both object shift and HNPS, or the multiple object shift approach (47c). Takahashi claims that the latter option is available, since Icelandic (and Danish) allow multiple object shift, as illustrated in (48) below (Takahashi 2003b, example from Anagnostopoulou 2002:7-8).

(47) a. ?John would give Bill a book more often than he would give Susan a paper.

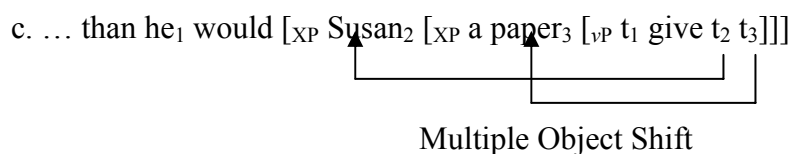
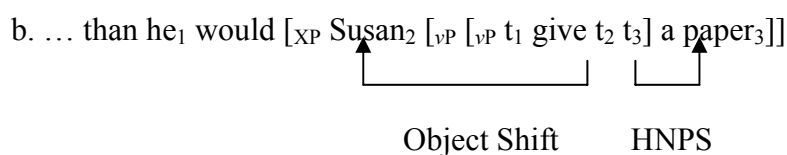



(48) Ég skilaði manninum bókinni ekki
I returned the-man-DAT the-book-DAT not
'I didn't return the book to the man.'

From the derivations in (47), we can also draw the conclusion that the direct object remnant, *a paper* can actually be moved via object shift, which previously was excluded in transitive

constructions. Hence, the remnant in transitive clauses can be derived either via Heavy NP Shift (49b) or Object Shift (49c) (Takahashi 2003b), and the table in (50).

(49) a. John will select me, and Bill will ~~select~~ you.

b. ... Bill₁ will [_{VP} [_{VP} t₁ select t₂] you₂]

 HNPS

c. ... Bill₁ will [_{XP} you₂ [_{VP} t₁ select t₂]]

 Object Shift

(50)

Type of Remnant	Heavy NP Shift	Object Shift
object in transitive clauses (single remnant)	✓	✓

5.6.4. Deriving Pseudogapping with multiple remnants in dative constructions

Given that the indirect object remnant in dative constructions can only be derived via Heavy NP Shift, as we have seen above, and multiple Heavy NP Shift is not permitted in any case, the only possible way to derive the sentence in (51a) is via Takahashi's eclectic approach, combining both Heavy Noun Phrase Shift and object shift (51b) (Takahashi 2003b).

(51) a. Although he wouldn't give the book to Bill, he would ~~give~~ the paper to Susan.

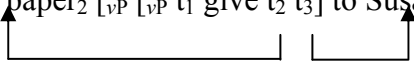
b. ... he₁ would [_{XP} the paper₂ [_{VP} [_{VP} t₁ give t₂ t₃] to Susan₃]]

 Object Shift HNPS

Again, the observation that the first remnant can undergo object shift in these circumstances points to the optionality that we found in the transitive constructions, as illustrated in (50) above.

In the following table (52), the findings from the distribution of remnants from the above discussion, and their potential to license parasitic gaps are brought together, thus linking the

evidence provided in the discussion in the first part of this chapter to the actual structural derivation of the Pseudogapping remnants in question.⁶⁷

(52)

Type of Remnant	Heavy NP Shift	Object Shift	Parasitic Gaps?
object in transitive clauses (single remnant)	✓	✓	yes/no
direct object remnant in double object constructions	✓	*	yes
direct object remnant in dative constructions	✓	✓	yes
Type of Remnant	Heavy NP Shift	Object Shift	Parasitic Gaps?
indirect object in double object constructions	*	✓	no
indirect object in dative constructions (the PP)	✓	*	no (PPs)
Multiple Remnants	Heavy NP Shift	Object Shift	Parasitic Gaps?
two remnants in double object constructions	*twice ✓once (direct object)	✓twice ✓once (indirect object)	n/a
two remnants in dative constructions (the PP)	*twice ✓once (indirect object)	*twice ✓once (direct object)	n/a

⁶⁷ In the instances marked as *n/a*, it is extremely difficult to construct examples such that they actually license parasitic gaps. The problem is compounded by the fact that Pseudogapping with multiple remnants are slightly degraded with respect to their single remnant counterparts, and the observation that many speakers rate sentences with parasitic gaps as marginal, regardless of the context they occur in.

In sum, even with the reservations with respect to the licensing of parasitic gaps as such, as noted above, the picture we obtain from the table in (52) provides some support for an A-bar-movement account of Pseudogapping.

In the next chapter, I will treat the question of whether a hybrid approach is actually necessary to explain all instances for Pseudogapping. For the moment, though, I conclude that the behaviour of the remnants in Pseudogapping, as illustrated in the table in (52), is hard to capture under a strict A-movement account such as object shift.

5.7. Conclusion

In this chapter I have investigated the Binding effects that occur with the Pseudogapping construction. I concluded that many of the effects that are associated with a A-movement account can also be accommodated in an A-bar-movement account, and have provided an example of how this A-bar-movement account, albeit in terms of Heavy Noun Phrase Shift, can be implemented, as suggested in Takahashi's (2003a, b, 2004a) hybrid account of Pseudogapping.

In the next chapter and the chapter that follow, I will present my own analysis of Pseudogapping. Building on the findings from the present chapter, as well as chapter 4, I propose that Pseudogapping involves focus movement. Accordingly, the next chapter is devoted to the investigation of syntactic focus movement. On the basis of this movement, which is implemented by means of a focus feature in syntax, I then proceed to discuss the semantic requirements on focus and deletion. This, in turn, lays the foundation for the particular approach to deletion that I will adopt and outline in chapter 8, before moving to the final chapter of this dissertation, in which I will put the two dimensions of focus and ellipsis together to derive a uniform account of ellipsis.

6. Syntactic Focus Movement

From the arguments presented in chapter 4 and chapter 5 the conclusion can be drawn that the movement involved in the Pseudogapping may be A-bar-movement rather than A-movement. In this chapter, I will show that this A-bar-movement operation is best explained in terms of syntactic focus movement, which can account for the data that are puzzling in an A-movement approach to Pseudogapping.

I will begin with a discussion of the role of focus in the A-movement accounts that we have seen so far, and contend that focus can actually be assumed to be a feature that is responsible for the movement of the object remnant in Pseudogapping. I will then show that if focus is incorporated in the syntactic derivation of Pseudogapping, there are two possible accounts of A-bar-movement that could do justice to the information-structural effects in Pseudogapping, namely, Heavy NP Shift, and focus movement. I will first discuss the first option, rightward A-bar-movement in terms of Heavy NP Shift, and show that the distribution of Pseudogapping remnants points rather to an analysis that is less restricted than Heavy NP Shift. Moreover, I will show that the arguments provided in Takahashi's (2003a, b, 2004a) eclectic approach, combining both object shift and Heavy NP Shift, fall short of explaining the consistent pattern of contrastive focus on the Pseudogapping remnant. Since, on the other hand, these effects can equally well be captured in a focus movement account, I propose that the focus movement account can also accommodate the data that are problematic for Takahashi's (2003a, b, 2004a) analysis.

I will then move on to a detailed discussion of the phenomenon of focus movement, providing first cross-linguistic evidence for a focus position above the vP layer, which could subsequently serve as a landing site for the Pseudogapping remnant. I will then show that the prosodic properties in ellipsis contexts also favour an account in terms of focus. Building on Jayaseelan's (2001) analysis of focus movement in Pseudogapping, I will subsequently evaluate the structural proposals that have been suggested for the Pseudogapping configuration, and conclude that A-bar-movement is taking place in each case, although, in

rare cases, it might be necessary to derive remnants with a combination of A-movement and subsequent obligatory A-bar-movement.

6.1. The Role of Focus in A-Movement Accounts

For the proponents of the A-movement approach to Pseudogapping, focus does not play a crucial role. Baltin, for instance (Baltin 2000: 37), adopts the view that ellipsis is a process which need not actually involve syntactic focus movement. He claims that the function of VP Ellipsis is “to cause focal stress to occur on the remnant, by removing the VP containing the remnant from the potential for bearing focal stress”.⁶⁸

While this seems to be a valid hypothesis (and, incidentally, one that is also adopted in a different version in Gergel, Gengel and Winkler 2007), Baltin’s (2003: 215) claim, however, that “given that the ellipsis remnant is focused, focus cannot be explicitly represented in syntactic representations, but rather must be interpretive in nature [sic!]” is, to put it mildly, a rather astonishing conclusion. Of course, banning focus from syntactic structure is a necessary presumption for his analysis, since, according to him, the remnant in Pseudogapping necessarily moves to an A-position (cf. Baltin 2003: 218).

Lasnik (2001a: 121), in turn, notes that Kim (1997) provides arguments to the effect that the position the Pseudogapping remnant moves to actually has a focus feature. He suggests that, on the basis of the optionality of object shift presumed in his own analysis, “a fruitful line of inquiry would center on focus effects with raised objects and ECM subjects in general” (Lasnik 2001a: 121, fn. 20).

The conclusion to be drawn from this section is thus the following: if Pseudogapping does indeed involve focus (either as a feature or as a side effect), as there is reason to believe it does, there is a possibility that the derivation of Pseudogapping makes use of information-

⁶⁸ Baltin (2000: 38) supports his claim with an observation made by Levin (1986) that Pseudogapping always occurs with subjects that are “identical to the subjects of the clauses containing the antecedent VPs” (ibid.), which, in his view, allows the creation of a unique focus domain. Although the examples he provides are in keeping with this observation, there are other Pseudogapping examples, which contradict this statement, such as (i) (Lasnik 1999d: 162; his (50)).

(i) Bill selected a portrait of John, and Susan should a picture of Mary.

structural processes, which would, again, point to an approach in terms of A-bar-movement rather than A-movement.

As mentioned in the introduction, if Pseudogapping is indeed derived via A-bar-movement, there are two A-bar-movement processes that have been suggested in the literature, Heavy NP Shift (Jayaseelan 1990, Takahashi 2003a, b, 2004a, and Johnson 2005), and Focus Movement (Jayaseelan 2001), which we can invoke in the Pseudogapping derivation.

As both of these approaches crucially imply the concept of focus (or contrast, as in Jayaseelan 1990), the main difference between the two lies in the structural configuration, that is, in the distinction between leftward and rightward movement, which I will discuss in the following sections.

6.2. Rightward A-bar-Movement: Heavy NP Shift

In this section, I will reconsider some of the observations made already in the literature review (cf. chapter 3).

6.2.1. The Distribution of Heavy NP Shift and Pseudogapping remnants

As we have seen in chapter 3, Jayaseelan (1990: 65) proposes that the extraposition process in Pseudogapping is an instance of Heavy Noun Phrase Shift (HNPS), or “Focus NP Shift” (in Rochemont’s 1978 terminology). HNPS is considered to adjoin an NP to the right of a VP, in order to focus it. This is illustrated in the examples in (1) (Jayaseelan 1999: 65, his (4)).

- (1) a. They [_{VP} brought [_{NP} the man who was being interrogated] into the room]
b. They [_{VP} [_{VP} brought t_i into the room] [_{NP_i} the man who was being interrogated]]

In (2), the same process is applied to particle shift (an analysis Jayaseelan attributes to Kayne 1985, with α being a small clause).⁶⁹

- (2) a. John [_{VP} looked [_{α} [_{NP} the information] up]]
b. John [_{VP} [_{VP} looked [_{α} t_i up]] [_{NP_i} the information]]

On the basis of these data, Jayaseelan (1990: 66) proposes that the extraposition process in Pseudogapping is also an instance of HNPS. He supports his claim with the following three arguments.

Firstly, HNPS obligatorily pied-pipes a preposition when an object of a preposition is moved ((3a-c), Jayaseelan 1990: 66, his (7)), even if the related processes of *wh*-movement and NP movement do not pied-pipe the preposition ((3d-e), Jayaseelan 1990: 66, his (7)).

- (3) a. John counted [_{PP} on a total stranger] for support.
b. John counted for support on a total stranger.
c. *John counted on for support a total stranger.
d. Who did John count on for support?
e. A total stranger was counted on for support.

This observation leads Jayaseelan (1990: 66) to predict that the object of a preposition does not occur as a Pseudogapping remnant without its preposition. This is borne out, as shown in (4) (*ibid.*, his (8)).

- (4) a. You can't count [_{PP} on a stranger]; but you can count [_{PP} on a friend]
b. You can't count on a stranger; but you can on a friend.
c. *You can't count on a stranger; but you can a friend.

Secondly, Jayaseelan (1990: 66) notes that multiple HNPS (of NPs) is ungrammatical in general (5) (Jayaseelan 1990: 66, his (9)). Likewise, Pseudogapping cannot have more than one remnant (6) (*ibid.*, his (10)).

⁶⁹ Note that consequently, the movement in particle constructions also involves rightward movement, in contrast to the analyses presented in Johnson (1991) and Lasnik (e.g. 1999a). I will not elaborate on this difference here.

- (5) *It proved to the jury his guilt that John was seen with the murder weapon.
(vs. It proved his guilt to the jury that John was seen with the murder weapon.)

- (6) *I didn't give a dime to Mary, but I did a nickel to Jane.

The third argument that Jayaseelan provides is the "Focus (or Heaviness) Constraint on the extraposed constituent", which is observed in both HNPS and Pseudogapping (Jayaseelan 1990: 67).

However, these empirical observations are not conclusive. Indeed, one of the main reasons to adopt an A-movement account instead of the Heavy Noun Phrase Shift approach (which preceded the A-movement account in the literature) lay in the asymmetries found in the distribution of Pseudogapping and Heavy Noun Phrase Shift, as summarised in Lasnik (1995a).

Lasnik (1995a: 145; cf. also 1999: 143ff.) points out that Pseudogapping is possible with the first object of a double object construction, as shown in (7), as opposed to the corresponding Heavy NP Shift example in (8) (taken from Lasnik 1995a: 145, his (19) and (20)).

- (7) ?John gave Bill a lot of money, and Mary will ~~give~~ Susan ~~a lot of money~~.

- (8) *John gave *t* a lot of money the fund for the preservation of VOS languages.

According to Lasnik, the opposite state of affairs holds for the second object in a double object: while Pseudogapping is impossible (9), Heavy NP Shift is fine (10) (Lasnik 1995a: 145, his (21) and (22)).

- (9) *John gave Bill a lot of money, and Mary will ~~give Bill~~ a lot of advice.

- (10) John gave Bill *t* yesterday more money than he had ever seen.

A third counterargument against the HNPS approach is that, while both Pseudogapping and HNPS involve focal stress, NPs may shift where Pseudogapping is not available (Lasnik 1995a: 145f.), as illustrated in (11) and (12) (ibid., his (23) and (24)).

(11) Speaker A: Is she suing the hospital that bungled the operation?

Speaker B: Yes, she is suing *t* in federal court the hospital that bungled the operation.

(12) Speaker A: Is she suing the hospital that bungled the operation?

Speaker B: *Yes, she is \emptyset the hospital that bungled the operation.⁷⁰

Lasnik (1995a: 146) also notes that pronouns (with the exception of *it*) are good Pseudogapping remnants (13), while they generally do not undergo HNPS (14) (*ibid.*, his (25) and (26)).

(13) John will select me, and Bill will you.

(14) *? Bill will select tomorrow you.

On the basis of the above differences between Heavy Noun Phrase Shift and Pseudogapping Lasnik (1995a) suggests that the movement involved in Pseudogapping is Object Shift rather than Heavy NP Shift. While the conclusion that the movement necessarily is object shift instead of Heavy NP Shift is not the only conclusion that can be drawn from the above data, as we will see below, the midway result, that is, that the object movement in question does not seem to be Heavy NP Shift, given the distributional differences between Heavy NP Shift and Pseudogapping, is certainly valid.

6.2.2. Heavy NP Shift in the Hybrid Account of Pseudogapping

As we have seen in the previous chapter (ch. 5), the object shift analysis and the Heavy NP Shift analysis, however, can also exist side by side, as proposed in Takahashi's (2003a, b, 2004a) account of Pseudogapping. In what follows, I will thus briefly review the instances in which Takahashi assumed Heavy NP Shift to be the only possible movement in the derivation of Pseudogapping.

⁷⁰ Note that this example may be ruled out independently, due to the difficulties with the status of 'be' in Pseudogapping.

The first instance where Heavy NP Shift is invoked as movement in Takahashi's (2003a, b, 2004a) account is the derivation of direct object remnants. Recall that, regardless of the Scandinavian evidence, leftward movement, that is, object shift, does not seem to respect the requirement that ellipsis target constituents, as shown in (15), where a non-constituent structure is elided.

(15) a. Although he wouldn't give Bill the book, he would the paper.

b. [TP he₁ would [VP t₁ [AgrP₂ Bill₂ [VP₂ t₂ [AgrP₃ the paper₃ [~~VP₃ give t₃]]]]]]]]~~

However, Takahashi's (2003a) argument hinges on the observation that the direct object, the paper, cannot be moved across the indirect object, in accordance with the relevant facts from Scandinavian. He thus concludes that the only way to salvage the deletion of a constituent is by having rightward movement, Heavy NP Shift, which, as illustrated in (16) below, does not cause the impression of scattered deletion, as in (15).

(16) *Direct object remnant in double object construction*

a. Although he wouldn't give Bill the book, he would ~~give Bill~~ the paper.

b. ... he₁ would [vP [vP t₁ give Bill t₂] the paper₂]

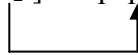

HNPS

If, on the other hand, the direct object could move past the indirect object, via A-bar-movement (though leftward A-bar-movement), there should be no reason to worry about the restriction of constituent deletion, as shown in (17) below, since the underlying structure of the phrase remains the same as in (16), apart from the actual direction of movement.⁷¹

(17) [TP he₁ would [vP the paper₂ [vP t₁ [~~VP₂ give Bill t₂]]]]]~~

Thus, there does not seem to be any crucial requirement as such to the effect that the movement in question should actually be rightward A-bar-movement.

⁷¹ Note that the structure in (17) is modified from Takahashi's (2003a) structure, replacing the Agreement projections with the vP layer, as in his example in (16) (Takahashi 2004a).

The same reasoning holds in the derivation of PP remnants in dative constructions. As Takahashi (2003a) points out, for the indirect object remnant in dative constructions, i.e. the PP, the movement type in question is limited to HNPS, since Heavy NP Shift is possible with prepositional phrases (cf. (18) below), whereas Object Shift (in Scandinavian) is not.

- (18) a. Sue gave the book t_1 on Friday [to John]₁. (Pesetsky 1995: 261)
 b. We gave t_1 to John on Friday [a brand-new toy]₁. (Pesetsky 1995: 249)

The corresponding structure assumed in Takahashi (2003a, b, 2004a) is thus as in (19).

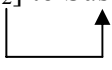
- (19) a. Although he wouldn't give the book to Bill, he would ~~give the book~~ to Susan.
 b. ... he₁ would [_{VP} [_{VP} t_1 give the book t_2] to Susan₂]

 HNPS

Again, the question arises whether this structure should not be amenable to a leftward focus movement analysis, since the prepositional remnant is often used to indicate a certain prominence, and would therefore, despite its failure to license parasitic gaps, be principally available for a focus movement analysis.

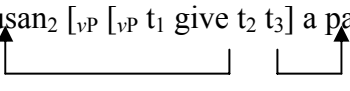
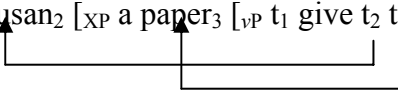
While the two specific types of remnants are, according to Takahashi (2003a, b, 2004a), excluded from an A-movement analysis, there are other cases in which A-movement could still be an optional derivation, as in the cases of multiple remnants in double object constructions and dative constructions. Consider first the remnants in a double object construction such as (20).

- (20) a. ?John would give Bill a book more often than he would ~~give~~ Susan a paper.
 b. ... than he₁ would [_{XP} Susan₂ [_{VP} [_{VP} t_1 give t_2 t_3] a paper₃]]

 Object Shift HNPS
 c. ... than he₁ would [_{XP} Susan₂ [_{XP} a paper₃ [_{VP} t_1 give t_2 t_3]]]

 Multiple Object Shift

Following Takahashi (2004a), since the multiple application of Heavy Noun Phrase Shift is not permitted on independent grounds, there is either the eclectic approach (20b), involving both object shift and HNPS, or the multiple object shift approach (20c). As I will return to the specific focus effects found in Pseudogapping in later sections of this chapter, I would like to point out that, unlike in the cases above, there does not even seem to be a principled reason to block leftward movement (as multiple object shift is allowed in the Scandinavian languages used in Takahashi's (2003a, b, 2004a) line of argument). Thus, one might very well argue that there should not be a need for a leftward movement *and* rightward movement taking place side by side in one single sentence. While this, on the surface, might only be a theoretical subtlety, the question also arises on how the linear order is preserved between the two elements, if the Heavy NP shifted argument is right-adjoined in the structure.⁷² As I will show in later sections of this chapter, Heavy NP Shift could also be replaced by leftward focus movement in this instance.

An interesting consequence of the derivation in (20c) is the fact that the direct object remnant, *a paper*, can actually be moved via object shift, which previously was excluded in transitive constructions. Hence, the remnant in transitive clauses can be derived either via Heavy NP Shift (21b) or Object Shift (21c) (Takahashi 2004a). What is crucial from this observation is that, again, a leftward focus movement, i.e. A-bar-movement, could subsume the two possibilities of derivation that are illustrated in (21).

(21) a. John will select me, and Bill will ~~select~~ you.

b. ... Bill₁ will [_{VP} [_{VP} t₁ select t₂] you₂]



HNPS

c. ... Bill₁ will [_{XP} you₂ [_{VP} t₁ select t₂]]

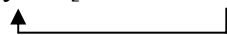

Object Shift

The final instance in which Takahashi (2003a, b, 2004a) assumes the hybrid account is the derivation of multiple remnants in the dative constructions. As pointed out above, the object

⁷² Obviously, this is also a problem for the approaches that assume leftward movement twice, although there, it might be simpler to resolve.

PP is not available for object shift, and thus must undergo Heavy NP Shift in Takahashi's (2003a) analysis. Neither is multiple Heavy NP Shift permitted, as also indicated above.

The only possible way to derive the sentence in (22a) is via Takahashi's eclectic approach, combining both Heavy Noun Phrase Shift and object shift (22b) (Takahashi 2003b).

(22) a. Although he wouldn't give the book to Bill, he would give the paper to Susan.

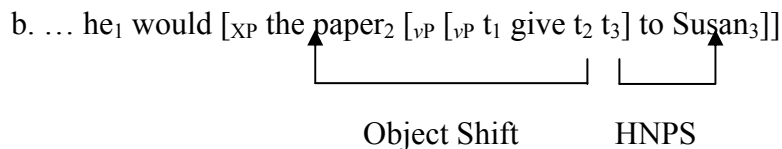

Again, the question arises of whether it is desirable to have both leftward and rightward movement in the derivation of a single sentence. In this case, however, in contrast to the derivation of multiple remnants in double object constructions (as in (20) above), there is no possibility to have two instances of the same movement, that is, no multiple object shift is allowed. However, as the PP could, in principle, also undergo leftward focus movement, as indicated in the discussion above, there could be the possibility of a multiple leftward movement, more specifically, leftward A-bar-movement, focus movement.

The table in (23) below summarises the different possibilities we obtain for the derivation of the individual remnants. Crucially, the focus movement can account for all remnants in question.

(23)

Type of Remnant	Heavy NP Shift	Object Shift	Focus Movement
object in transitive clauses (single remnant)	✓	✓	✓
direct object remnant in double object constructions	✓	*	✓
direct object remnant in dative constructions	✓	✓	✓

Type of Remnant	Heavy NP Shift	Object Shift	Focus Movement
indirect object in double object constructions	*	✓	✓
indirect object in dative constructions (the PP)	✓	*	✓
Multiple Remnants	Heavy NP Shift	Object Shift	Focus Movement
two remnants in double object constructions	*twice ✓once(direct object)	✓ ✓once (indirect object)	✓twice
two remnants in dative constructions (the PP)	*twice ✓once (indirect object)	*twice ✓once (direct object)	✓twice

From the discussion above, we may conclude that focus movement in terms of leftward movement can actually derive each instance of Pseudogapping. In the sections that follow, I will further motivate this focus movement approach to Pseudogapping.

To conclude the discussion on Heavy NP Shift, however, it needs to be pointed out that there are other accounts of Heavy NP Shift that do not consider it rightward movement but leftward movement of the verb, as in Johnson's (2005) approach, illustrated in (24) below.⁷³

- (24) a. She might give to me something replaceable, but she wouldn't \emptyset something important.
 b.

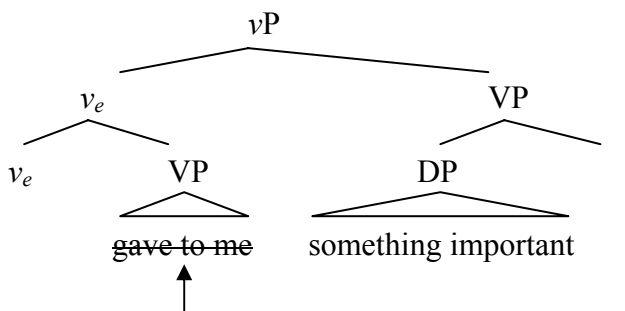

⁷³ In some sense, a change of direction in the movement rather than non-movement of the object in Johnson's (2005) account) is also assumed in Kim (1997) who contends on the basis of Korean that focus movement should be rightward movement in English.

While this kind of movement should capture the overall properties of focus in Pseudogapping, the restrictions on Heavy NP Shift that have been noted above should still hold, thus making this account less parsimonious than the focus movement account.

Moreover, given Johnson's (1991) account of obligatory object shift in English, there is no doubt that the verb should move in all sentences in English, to preserve the correct surface word order. As we will see in the next chapter, however, there is reason to believe that the verb in Pseudogapping does not raise (as also suggested in Lasnik's (1995a, 1999a, a.o.) analysis, cf. the discussion in chapter 4). On this assumption, it would thus be difficult to explain why the verb has to move to adjoin to vP , prior to deletion.

In the following sections, I will discuss the motivations for syntactic focus movement in Pseudogapping in English in more detail, beginning with an overview of cross-linguistic evidence for focus movement to a position situated above the vP layer.

6.3. Syntactic Focus Movement from a Cross-linguistic Perspective

There are several focus positions available in the sentence structure that are attested cross-linguistically, the most common probably being in the CP domain (cf. Rizzi 1997).⁷⁴ The position I am interested in in this section, though, is a focus position above the VP level, as this would be the position where the remnant in Pseudogapping (and potentially, Gapping) moves to. In what follows, I will give a brief overview of phenomena where a focus position (with focus movement) has been assumed above VP.

6.3.1. Hebrew

Belletti and Shlonsky (1995) show that in Italian and Hebrew, the changes in the base order NP PP that they assume for double object structures can be derived via movement to a focus position above VP, yielding the alternative PP NP order.

⁷⁴ Here and throughout the dissertation, I will take the presence of this focal position for granted, and will only briefly mention its motivation for English in the discussion of the Sluicing cases in chapter 9.

In Hebrew, this is achieved via preposing the PP to the specifier of the Focus Phrase. The focalised status of the PP becomes obvious in the question-answer pair in (25) and (26) (Belletti and Shlonsky 1995: 511f., their (37)). The answer given in (26a) is a felicitous answer to (25), with the order PP NP, whereas (26b) is not an appropriate answer to the question in (25).

(25) le-mi carix le-haxzir [?]et ha-maftexot?
to-who must to-return ACC the-keys
 To whom does one/do we have to return the keys?

(26) a. carix le-haxzir le-Rina [?]et ha-maftexot.
(one) must to-return to-Rina ACC the-keys
 b. #carix le-haxzir [?]et ha-maftexot le-Rina.
(one) must to-return ACC the-keys to-Rina

With the Hebrew examples, it is the PP that is situated in the specifier of a focus projection. This observation in itself is interesting with regard to the Pseudogapping construction, since there seems to be a preference for PP remnants in these constructions as well (cf. Levin 1986, and the Scandinavian data cited in Gengel 2006f).

6.3.2. Italian

For Italian, Belletti and Shlonsky (1995) show that the picture in question-answer pairs is similar to the situation found in Hebrew. This is illustrated in (27) and (28) below (Belletti and Shlonsky 1995, their example (26)).

(27) Che cosa hai restituito a Maria?
What did you give back to Maria?

(28) a. Ho restituito a Maria le chiavi.
I gave back to Maria the keys.
 b. #Ho restituito le chiavi a Maria.
I gave back the keys to Maria.

As in Hebrew, the NP PP order in (28b) is only marginally appropriate as an answer to the question in (27), which points to the fact that in (28a), *le chiavi* receives a certain amount of stress.⁷⁵ Thus, Belletti and Shlonsky conclude that the order PP NP in the felicitous answer in (28a) is derived via postposition of the NP, which they consider to be a process of focalisation.⁷⁶

6.3.3. Hungarian

In Hungarian, there is also overt focus movement (as discussed in e.g. Kíss (1998)). In the syntactic derivation of the example given in (29) (from Kíss 1998: 256, her example (29)), the focused constituent moves to the specifier of a focus phrase above *vP*, as illustrated in the (slightly modified) tree structure in (30) below.^{77,78}

(29) Mari Peterre szavazott.

Mari Peter.on voted.she

‘(As for) Mary, it was **Peter** that she voted on.’

One particular property of this focus movement in Hungarian is that only elements that are either contrastive (cf. Szendroï 2001) or exhaustive (cf. Kíss 1998) move to a special focus projection in the sentence.⁷⁹

⁷⁵ Belletti and Shlonsky (1995: 503) note that (28a) seems pragmatically odd, too. This can be remedied, however, by the pronominalisation and cliticisation of the indirect object, yielding the sentence in (i).

(i) *Le ho restituito le chiavi.*
to her I returned the keys.

⁷⁶ A complication arises if the NP in question is heavy, and does not seem to undergo movement. To handle these cases, Belletti and Shlonsky (1995: 506) suggest that the object remains in situ (being heavy enough to receive stress), and that the order PP NP is then derived via PP scrambling (which they take to be different from the process found in Hebrew). I will not pursue the matter here, as the discussion provided above is only intended to show that there is a focalisation process affecting object NPs in Italian, which triggers their movement to a structural focus position.

⁷⁷ The fact that the subject *Mari* in (29) is topicalised is not crucial for our purposes here.

⁷⁸ Note that the movement of the verb to the Focus head indicated in (30) is a special property of Hungarian. In this respect, it differs from English, as pointed out by Kíss (1998: 256).

⁷⁹ I will return to the difference between English focus movement and Hungarian focus movement at the end of the chapter.

On the other hand, elements that are only marked as being information focus or presentational focus (according to Kíss' (1998) terminology) do not undergo syntactic focus movement. As we will see in the following sections, these elements are very similar to the ones that can undergo focus movement in English.

(30)

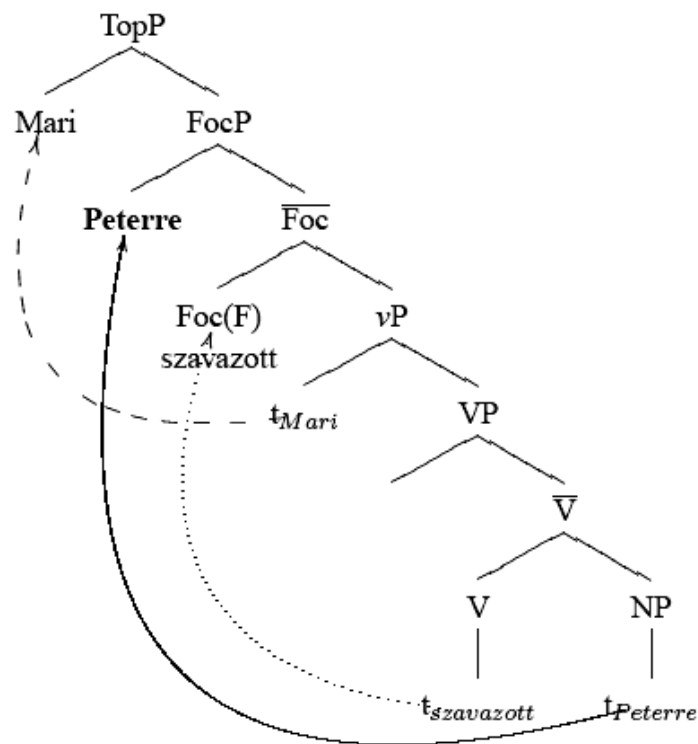

In Kíss (1998), the condition for syntactic focus movement is captured in the following definition of contrastive focus (31).

(31) *Identificational (=contrastive) Focus (Kíss 1998)*

An identificational focus represents a subset of the set of contextually or situationally given elements for which the predicate phrase can potentially hold; it is identified as the exhaustive subset of this set for which the predicate actually holds.

This definition holds for the relevant elements in the example given in (29) above, since *Peterre* has an exhaustive reading, as in it being Peter and nobody else that Mari voted for.

(Incidentally, this is translated with an English cleft structure which also obeys the exhaustivity requirement. Cf. Kiss (1998)).

6.3.4. Malayalam

Jayaseelan (2001) claims that in Malayalam a focus phrase above the vP level accounts for the position of the question word, which is contiguous to V, and, according to Jayaseelan, has a strong focus feature. An example of the relevant question formation is given in (32) (Jayaseelan 2001: 40, his (1)). In (32a), the question word *aarə* is next to the verb *aTiccu*, and the question is grammatical, and (32b) is ruled out because the question word is separated from the verb by the object.

(32) a. ninn-e *aarə* aTiccu?

you-acc. who beat-past

‘Who beat you?’

b. **aarə ninn*-e aTiccu?

Based on the hypothesis that the surface order in SOV languages results from raising the object to functional projections between IP and VP (Jayaseelan 2001: 41), Jayaseelan assumes that there is a Focus Phrase which immediately dominates vP . In this configuration, the question word ends up next to V, since it moves into the specifier of the focus phrase. In (32a), the subject *who* as a question word moves into [Spec,FocP], and the object *you* moves higher up, past the subject, as in (33).⁸⁰

⁸⁰ See Jayaseelan (2001: 41, fn. 3) for a short discussion on potential intervention effects.

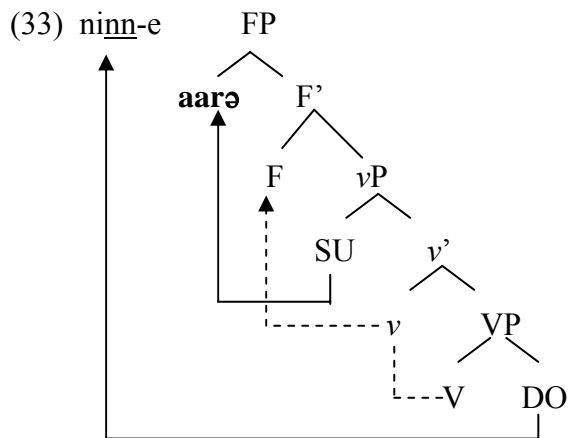

In Malayalam, the surface order of questions can also be a cleft structure, where the question word or larger phrase with the question word inside is put in ‘cleft focus’ (Jayaseelan 2001: 63). This cleft focus is then moved into the specifier of a Focus Phrase above VP. Thus, for a cleft sentence such as (34) (Jayaseelan 2001: 63, his (54a)), we obtain the phrase structure in (35) (ibid., his (54b)). Note that Malayalam is a *pro*-drop language (which accounts for the expletive *pro* in the subject position in (10)).⁸¹

(34) Mary-(y)e aaNə [ñaan kaND-atə]
 -acc is I saw-nominalizer
 ‘It is Mary that I saw.’

(35)

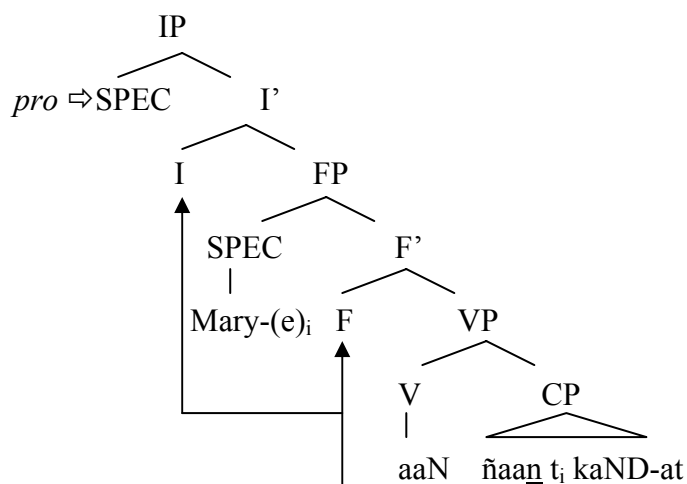

⁸¹ The assumption of an expletive *pro* has been refuted in Alexiadou and Anagnostopoulou (1998). Jayaseelan points out (2001: 63, fn. 31) that alternatively, “the EPP feature is only optionally assigned to Malayalam INFL”. As it does not bear directly on the topic of the present discussion, I will not pursue the matter here.

6.3.5. Syntactic Focus Movement in English

Jayaseelan (2001) proposes that the focus position above VP can also account for English cleft constructions, the English clause-final focus marker *all*, and for English Pseudogapping.⁸²

For English clefts, the same derivation as for the Malayalam clefts (cf. (35) above) can be assumed. This is illustrated in (37) for the cleft sentence in (36) (Jayaseelan 2001: 63, his (53)).⁸³ (Note that English as a non-*pro*-drop language obligatorily merges the expletive *it* in subject position in (37)).

(36) It is Mary that I saw.

(37)

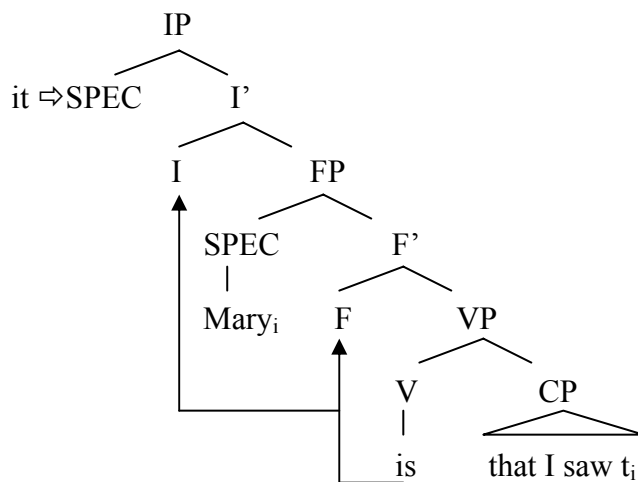

The structural derivation in (37) thus accounts for the focus meaning that the clefted sentence acquires.

With respect to clause-final focus markers in English (such as *themselves* in (38) below), Jayaseelan adopts the analysis of floated quantifiers in Sportiche (1988), and extends it to

⁸² There are also consequences for Scandinavian object shift and the German and Dutch ‘middle field’, which I will not consider here.

⁸³ In this case, movement to [Spec,FP] is not clause-internal, since *Mary* moves out of the embedded CP, which is an exceptional movement, but not unusual in cleft constructions, as noted by Jayaseelan (2001: 63, fn. 30).

account for the clause-final landing site in constructions such as the one in (38) (Jayaseelan 2001: 69, his (71)).

(38) They did it themselves.

If there is a focus phrase above *vP*, the position of *themselves* can be derived as follows. A subject DP with the focus marker moves into the specifier of the focus phrase, as shown in (39) (Jayaseelan 2001: 69, his (72a,b)).

(39) a. [_{vP} they themselves did it]
b. [they themselves]_i F⁰ [_{vP} t_i did it]

In a next step, the VP is preposed, as in the Heavy Noun Phrase Shift account proposed by Jayaseelan (see the discussion in the section on HNPS below for details), thus yielding the structure in (40a) (Jayaseelan 2001: 69, his (72c,d)). In a last step, the subject is raised to [Spec,IP], and strands the focus marker in the specifier of FP (40b).⁸⁴⁸⁵

(40) a. [_{vP} t_i did it]_j Top⁰ [they themselves]_i F⁰ t_j
b. they_k ... [_{vP} t_i did it]_j Top⁰ [t_k themselves]_i F⁰ t_j

As we will see below, this focus position that Jayaseelan (2001) assumes to be part of the English syntax will also figure in the derivation of English Pseudogapping. Before I turn to his analysis, and my extension thereof, I will discuss a configuration that has also been called Pseudogapping, and analysed via focus movement, namely, a VP Ellipsis-like construction in Korean and Japanese.

⁸⁴ Jayaseelan (2001: 70) notes that, apart from the subject, also objects with a focus marker may raise to [Spec,FP]. In this case, though, the object does not raise further to [Spec,IP], hence, the focus marker could not be stranded. If VP-preposing then applies, the movement of the object will either be rendered invisible, or the structure will be the same as in the HNPS structure (cf. Jayaseelan 2001: 68-70, and the relevant sections in this dissertation for further discussion).

⁸⁵ Jayaseelan (2001: 70, fn. 38) notes that in his analysis, phrases can be scrambled to [Spec,TopP] and [Spec,F[oc]P]. Thus, if scrambling exhibits both A- and A-bar-properties, he concludes that in this case, [Spec,FocP] might in fact have A-properties.

6.4. Syntactic Focus Movement in Korean Pseudogapping

Kim (1997) investigates a wide variety of ellipsis constructions, contrasting mainly data from Korean/Japanese with data from English. He claims that Korean and Japanese actually have a Pseudogapping construction, that is, a construction which involves focus movement and an auxiliary-like element. Kim (1997) suggests that the following sentences in (41) and (42) are cases of Pseudogapping in Korean (Kim 1997: 40f., his (49) and (50)).

(41) John-i sakwa-lul meke (kuliko) MARY-to [e] ya
-Nom apple-Acc eats and -Foc is
'John eats apples, and MARY does too'

(42) John-i sakwa-lul meke (kuliko) BANANA-to [e] ya
-Nom apple-Acc eats and -Foc is
'John eats apples and BANANAS, too'

In (41), the object has been dropped, and the verb has been elided, whereas in (42), the subject has been dropped. Compared to English, this construction seems thus more likely to pattern with VP Ellipsis. Nonetheless, Kim (1997: 41) contends that the above examples "are similar to English Pseudogapping constructions in that they have a remnant and an expletive (Aux) verb".⁸⁶ Despite their apparent similarity to English VP Ellipsis (cf. also fn. 21 below), the argument that the remaining element has to be marked with the focus marker *-to* could speak in favour of an analysis in terms of Pseudogapping instead of VP Ellipsis.⁸⁷ Albeit with some prior reservations as to the exact nature of this peculiar Pseudogapping construction, I will now turn to the focus movement he assumes to take place in these constructions.

First of all, Kim (1997: 45f.) shows that the focus movement in question necessarily is overt syntactic movement, as it obeys the relevant island constraints. Whereas (43) is grammatical,

⁸⁶ Kim (1997: 41ff.) actually adduces arguments from the recovery of adverbials and the obligatory presence of linguistic antecedents to show that Korean Pseudogapping patterns exactly like English VP Ellipsis.

⁸⁷ Note, however, that this is not what Kim (1997) claims, since he maintains (Kim 1997: 43) that the main difference between Korean *Pseudogapping* (in his terms) and English Pseudogapping is that in the former, the remnant has to be focused. This, in my view, is not true. If, as I am inclined to think, Korean Pseudogapping should be treated as a case of VP Ellipsis, then the main difference between the Korean VP Ellipsis-like construction and English VP *Ellipsis* might be the presence of obligatory focus in the Korean ellipsis construction.

(44) shows the configuration with movement past a complex NP, in (45), a wh-island is present, and in (46), the adjunct island is crossed over (Kim 1997: 45, his (59) to (62)).

(43) John-i [_{CP} Mary-ka Bill-ul salanghanta-ko] sayngkakhanta (kuliko) TOM₁-to
 -Nom -Nom -Acc loves-C thinks and -Foc
~~{_{VP} John-i [_{CP} Mary-ka t_i-salanghanta-ko] sayngkakhanta}~~ ya
 -Nom -Nom loves-C think is
 ‘John thinks that Mary loves Bill, and that Mary loves TOM too’

(44) ??John-i [_{NP} [_{CP} [_{IP} Mary-ka piano-lul yencwuhanta] nun] somwun]-ul tulessta
 -Nom -Nom -Acc play C rumor-Acc heard
 (kuliko) VIOLIN₁-to ~~{_{VP} John-i [_{NP} [_{CP} [_{IP} Mary-ka t_i-yencwuhanta] nun]}~~
 and -Foc -Nom -Nom play C
~~somwun]ul t_i]~~ ya -
 rumor -Acc hear is
 ‘John heard the rumor that Mary plays the piano, and that Mary plays the VIOLIN too’

(45) ??John-i [Mary-ka pizza-lul cohahanun ci] alko-siphehanta (kuliko) ICE
 -Nom -Nom -Acc like whether know-want and ice
 CREAM₁-to ~~John-i [Mary-ka t_i-cohahanun ci]~~ alko-sipheha ya
 cream -Foc -Nom -Nom like whether know-want is
 ‘John wants to know whether Mary likes pizza, and whether Mary likes ICE CREAM too’

(46) ??John-i [chayk-ul san hwue] pap-ul mekessta (kuliko) NOTHU₁-to ~~John-i~~
 -Nom book-Acc buy after rice-Acc ate and notebook-Foc -Nom
~~{_{NP} [t_i-san hwue] pap-ul}~~ mek ya
 buy after rice-Acc eat is
 ‘John ate rice after he bought a book, and after he bought a NOTEBOOK too’

According to Kim (1997: 54), the syntactic derivation of Korean Pseudogapping constructions, such as the ones in (41) and (42) above (here repeated as (47) and (48)) is as illustrated in the trees in (49) and (50), respectively (Kim 1997: 54, his (74) and (75)).^{88,89}

(47) John-i sakwa-lul meke (kuliko) MARY-to [e] ya
 -Nom apple-Acc eats and -Foc is
 ‘John eats apples, and MARY does too’

(48) John-i sakwa-lul meke (kuliko) BANANA-to [e] ya
 -Nom apple-Acc eats and -Foc is
 ‘John eats apples and BANANAS, too’

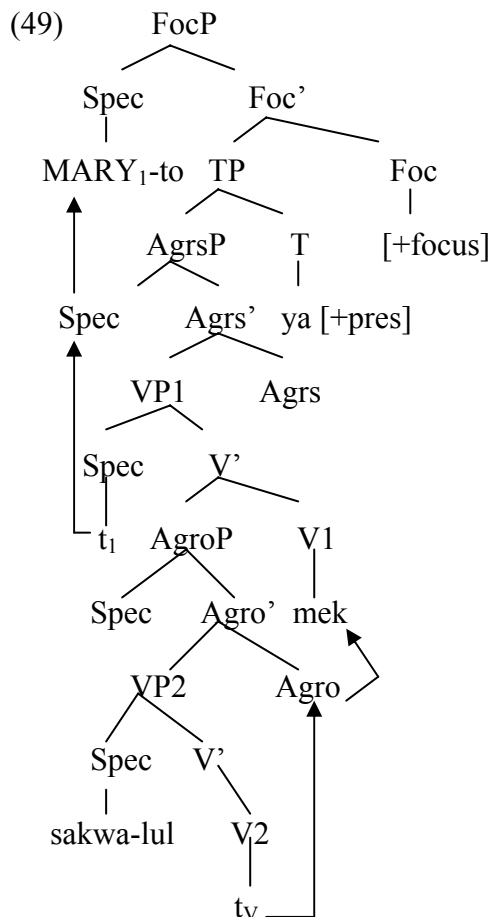

⁸⁸ The tree structures Kim (1997) gives for the Korean examples are left-branching, and head-final, which distinguishes them from the corresponding English examples. However, Kim also employs the Agr_OP , and the split VP structure (cf. Koizumi 1995, Lasnik 1999a, a.o.), which behave similar to their English counterparts.

⁸⁹ Note that Kim (1997: 55) assumes that the EPP on Agr_OP is weak in Korean, thus normally not triggering movement of either object or subject out of the VP. The θ -feature on the verb (triggering verb raising, cf. the discussion about verb raising in the previous chapter) is considered to be strong, thus, the verb raises to a higher V projection.

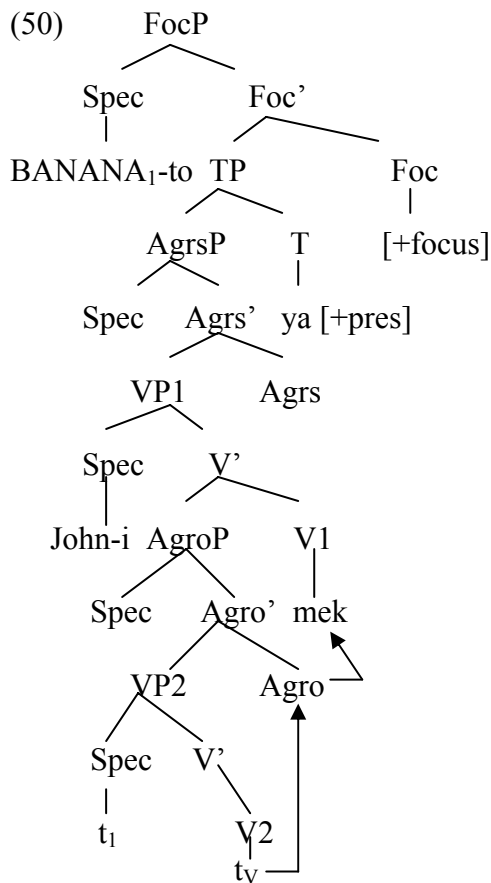

Crucially, though, the movement of either subject remnant or object remnant is taken to pass through the specifier of the Agr_O projection, i.e. there is no direct focus movement assumed, in the sense of A-bar-movement without intermediate landing sites. The reason for Agr_P as landing site is considered to be due to Case. As Kim (1997: 54f., fn. 29) puts it, “[f]ocalized subjects and objects cannot be Case-checked through the LF movement of its trace, given Chomsky’s (1995) proposal that the traces are invisible to the operation Move. *MARY-to* and *BANANA-to* thus must move overtly to Spec of $Agrs_P$ (74 [24]) and Spec of $Agro_P$ (75 [25]), respectively, to ensure that the derivations converge. That is, focalized subjects and objects undergoing overt movement to Spec of Foc_P are forced to move overtly to their Case-checking position (i.e., Spec of Agr_P), although they can otherwise remain in Spec of VP in overt syntax.”. However, movement to the specifier of the respective Agreement positions is no longer necessary, given the option of AGREE as case-checking operation.⁹⁰

⁹⁰ An issue that is related to this point is the claim Kim (1997) makes for the focus position in English, in his Sluicing analysis. He contends, for reasons that I do not find particularly convincing, that the specifier of the Focus Phrase in English is *final* (Kim 1997: 142), which amounts to focus movement being a rightward movement. I will not pursue this theory here (but see the discussion on Sluicing for more details). Note also that

As a final point, note that Korean Pseudogapping also works fine with prepositional remnants (in what Kim (1997: 55) calls ‘intransitive verb construction’). The same focus movement process that has been assumed for subjects and objects above thus applies to the sentences with PPs in (51) and (52) (Kim 1997: 55, his (76) and (77)).

(51) John-i secem-ey kanta (kuliko) MARY₁-to [~~vp t_i secem-ey~~—ka] ya
 -Nom bookstore-to go and -Foc bookstore-to go is
 ‘John goes to the bookstore, and MARY does too’

(52) John-i secem-ey kanta (kuliko) SUPER-EY₁-to [~~vp John-i t_i ka~~] ya
 -Nom bookstore-to go and supermarket-to-Foc -Nom go is
 ‘John goes to the bookstore, and to the SUPERMARKET too’

In sum, we can thus conclude from this subsection that Korean Pseudogapping exhibits focus movement, which adds further cross-linguistic evidence for the claim defended in the following sections, namely, that English Pseudogapping involves focus movement.

6.5. Syntactic Focus Movement in English Pseudogapping

In this section, I will show that English Pseudogapping can also be accounted for in terms of syntactic focus movement. I will begin with some remarks on prosodic prominence that we find in elliptical structures, thus motivating an analysis of elliptical constructions, notably Pseudogapping, where this information-structural requirement is incorporated in the syntactic derivation. I will then proceed to a discussion of Jayaseelan’s (2001) focus movement account for English Pseudogapping, and show potential structural configurations for the landing site of the object remnant.

this hypothesis is only shown for English Sluicing – unless I missed something crucial, there was no explicit illustration for English Pseudogapping.

6.5.1. Prosodic Prominence in Ellipsis Constructions

In sentences where no ellipsis takes place, such as in the example given in (53), prosodic prominence indicates where the two parts of the sentence differ (e.g. SHE vs. SUE in (53)), and prosodic reduction serves to mark the material that is invariant (Rooth 1992b: 1; his example (1), with capitals indicating prosodic prominence/focus).

(53) SHE beats me more often than SUE beats me.

In sentences where there is ellipsis, this interaction between prominence and reduction is even more obvious, as illustrated in (54) and (55).

(54) a. John left, and Bill did, too.

b. John [_{VP} left], and Bill did [_{VP} leave], too.¹

(55) John [_{VP} left], and Bill_F did [_{VP} leave].

Rooth (1992b: 13), for instance, claims that *Bill* is prominent (even without ellipsis), which, according to him, allows the conjecture that it may be a contrastive focus (where *Bill_F* signals focus on *Bill*, in Rooth's notation). On the basis of such data, Rooth concludes that the "link between ellipsis and contrastive focus is tenable" (1992b: 14; for a more detailed discussion and analysis see the chapter on focus semantics).

This observation is not only applicable for VP ellipsis, but can easily be extended to cover a wide variety of elliptical structure. Some examples from other instances of ellipsis are given in (56) to (59) below, where capitals are placed on the elements that receive some prosodic prominence in comparison to the other elements in the structure.

(56) 'Gerard Logan!' The tall dog-walker, astounded, bending to look at me, knew me by sight, as I did HIM.

(Dick Francis, *Shattered*, 68)

(*Pseudogapping*)

(57) Some gave the men peanuts and others CHOCOLATES.

(Johnson 1996)

*(Gapping)*⁹¹

(58) Jack bought something, but I don't know WHAT.

(Merchant 2001)

(Sluicing)

(59) I bought the red coat, and you bought the BLUE (one).

(NP ellipsis)

The above data suggest that there is indeed a clear focal requirement in ellipsis construction. This becomes clear if we look at the sentences above with no focus on the remnants, as illustrated in (56)' to (59)' below (where no capitals indicate no focus), which are all marginal if not ungrammatical without the focus on the remnant.

(56)' ?*... The tall dog-walker, astounded, bending to look at me, knew me by sight, as I did him.

(57)' ?*Some gave the men peanuts and others chocolates.

(58)' ?*Jack bought something, but I don't know what.

(59)' ?*I bought the red coat, and you bought the blue (one).

As we have seen in the discussion in the previous sections of this chapter, there are two possibilities to incorporate this information-structural requirement in the derivation of Pseudogapping, either with Heavy Noun Phrase Shift (rightward movement) or Focus Movement (leftward movement; cf. Jayaseelan 2001). We have seen that the Heavy NP Shift analysis and the hybrid account in Takahashi (2003a, b, 2004a), is not able to cover the full range of Pseudogapping remnants.

In what follows, I will argue that leftward focus movement is able to capture both the focus effects in Pseudogapping and the distribution of remnants. First, I will show that the hybrid account advocated in Takahashi (2003a, b, 2004a) does not explain the consistent focus

⁹¹ For expository reasons, I treat Gapping as an instance of ellipsis, roughly following the approach in Coppock (2001).

effects found with the Pseudogapping remnants. Secondly, building on the structural configuration in Jayaseelan's (2001) proposal of focus movement in English Pseudogapping, I will address the various possibilities of deriving leftward A-bar-movement in Pseudogapping, and conclude that in the cases that are analysed via object shift in Takahashi's (2003a, b, 2004a) hybrid account, a sequence of A-movement and A-bar-movement (naturally in that order) might be warranted.

6.5.2. Focus Effects in Pseudogapping: A Criticism of the Hybrid Approach

I have argued that all instances of Pseudogapping can, in principle, be derived via leftward movement. However, I have not yet discussed the cases in which Takahashi (2003a, b, 2004a), in his hybrid approach, already assumed leftward movement, albeit A-movement (similar to Lasnik's (1995a, 1999a, a.o.) analysis). These instances are illustrated in (60) and (61) (both with the AGR notation).

(60) a. John will select me, and Bill will ~~select~~ you.

b. (*)... Bill₁ will [_{VP} t₁ ~~select~~ t₂] you₂]



HNPS

c. ... Bill₁ will [_{VP} t₁ [_{Agrop} you₂ [_{VP} ~~select~~ t₂]]]

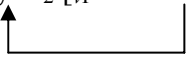

Object Shift

(61) *Indirect object remnant in double object construction*

a. Although he wouldn't give Bill the book, he would ~~give~~ Susan ~~the book~~.

b. ... he₁ would [_{XP} Susan₂ [_{VP} t₁ give t₂ the book]]]

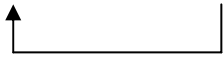

Object Shift

Recall that Takahashi (2003a, b, 2004a), following Lasnik (1995c, 1999c), assumed that in (60), the object shift should be preferred over the Heavy NP Shift account, due to the fact that

the object in (60) could not undergo Heavy NP Shift, as suggested by the ungrammaticality of (63) (example taken from Larson 1988: 354).

(62) Although he wouldn't give Bill the book, he would ~~give~~ Susan ~~the book~~.

(63) *Max gave t_1 a book about roses [the tall man in the garden]₁.

The hypothesis that the object remnant in (60) undergoes leftward A-movement is also supported by the failure to license parasitic gaps in this particular configuration, as shown in (64) (Baltin 2003: 241, his (51)).

(64) *Although John didn't kiss MARY_i without looking at e_i , he did SALLY_j without looking at e_j .

However, as we have seen in chapter 5, remnants in transitive constructions do license parasitic gaps, as shown in (65) (Takahashi 2004a). Thus, it seems that some of the remnants in transitive constructions are derived via A-bar-movement rather than A-movement.

(65) Although John didn't file a recent article about HNPS, he did [without reading e_1] [a recent article about Object Shift]₁.

The pattern we find in (64) and (65) is repeated with remnants in double object constructions. Takahashi (2003b) shows that indirect objects in double object constructions (in (66)) confirm the A-movement hypothesis, since, just as in constructions with a single ('indirect') object in (64) above, parasitic gap licensing is not possible either with indirect object remnants in double object constructions, which is illustrated in (66) (taken from Takahashi 2003b).

(66) a. *Although John didn't give the tall boy a book, he did [the short boy]₁ [without meeting e_1].

b. *Although John didn't give the tall boy a book, he did [without meeting e_1] [the short boy]₁.

Again, the direct object in double object constructions does not license parasitic gaps, as shown in (67) (Takahashi 2003b).

- (67) a. Although John didn't give the boy a short paper, he did [without reading e_1] [a long paper]₁.
b. Although John didn't give a short paper to Mary, he did [without reading e_1] [a long paper]₁.

From Takahashi's (2003a, b, 2004a) analysis, we would predict that the objects in the two instances of transitive constructions do not only exhibit a different behaviour with respect to the licensing of parasitic gaps, but also with respect to the focal properties on the remnant. As indicated in Baltin's (64) example above, however, the focus requirement is also fulfilled on indirect object remnants (irrespective of the ungrammaticality of the sentence, as other examples show, e.g. (68) below). Thus, there does not seem to be a perceptible difference with respect to the focus on the remnant that, if it existed, might be a natural consequence of the movement operation involved. The same situation is found with the remnants in double object constructions, with the indirect object in (69) and the direct object in (70), taken from Takahashi (2004b; his F-marking).

- (68) 'Gerard Logan!' The tall dog-walker, astounded, bending to look at me, knew me by sight, as I did HIM.
(Dick Francis, *Shattered*, 68)

(69) Although John wouldn't give Bill the book, he WOULD_F give SUSAN_F ~~the book~~.

(70) Although John wouldn't give Bill the book, he WOULD_F ~~give Bill~~ the PAPER_F.

The fact that the focus effects found on the remnants in Pseudogapping are not affected by the movement process that is allegedly involved allows two possible conclusions.

Firstly, as already hinted at above, if the focus effects were connected to the different movement types, we would expect different focus patterns on the remnants in Pseudogapping, contrary to fact. If, then, the focalisation of the remnant is independent of the movement involved, then, on the other hand, the assumption that Heavy NP Shift in

Pseudogapping is due to the inherent contrastiveness on the remnant (cf. Jayaseelan 1990) cannot be maintained.⁹² Thus, the focus effects seem to cut both ways: either their presence on arguments derived via object shift is not to be captured in syntactic terms, or their presence on arguments derived via Heavy NP Shift must be taken to be independently from Heavy NP Shift, which, however, otherwise clearly serves to emphasise a constituent.

The second conclusion that is possible in the face of the above situation is the hypothesis that the focus effects on the Pseudogapping remnants are indeed part of the syntactic derivation, thus favouring an A-bar-movement of the Pseudogapping derivation. With respect to the lack of parasitic gaps in the cases of indirect objects, it could be assumed that the remnant in these cases must undergo A-movement prior to A-bar-movement.

It is this latter hypothesis that I will discuss in detail in the following sections. I will first consider the structural configuration in Pseudogapping, building on the account in Jayaseelan (2001), and then relate the above-mentioned focus effects to the syntactic derivation of Pseudogapping.

6.6. The Syntactic Derivation of English Pseudogapping

6.6.1. The Landing Site of Syntactic Focus Movement

In this section, I will provide a detailed discussion of the position that the remnant in Pseudogapping may be moved to. Clearly, the position advocated in Lasnik's (1995a, 1999a, a.o.) analysis, [Spec,Agr_{OP}] should be considered an A-position, which virtually excludes it from being the (final) landing site for the focused Pseudogapping remnant.

In Jayaseelan's (2001) analysis, there is a focus phrase situated above the *v*P layer, to which the object remnant could move directly. The structural configuration according to his analysis is illustrated in (72) below (for the Pseudogapping example in (71)).

(71) John invited Susan, and Mary will Jane.

⁹² However, this is not explicitly assumed in Takahashi's (2003a, b, 2004a) analysis.

(72)

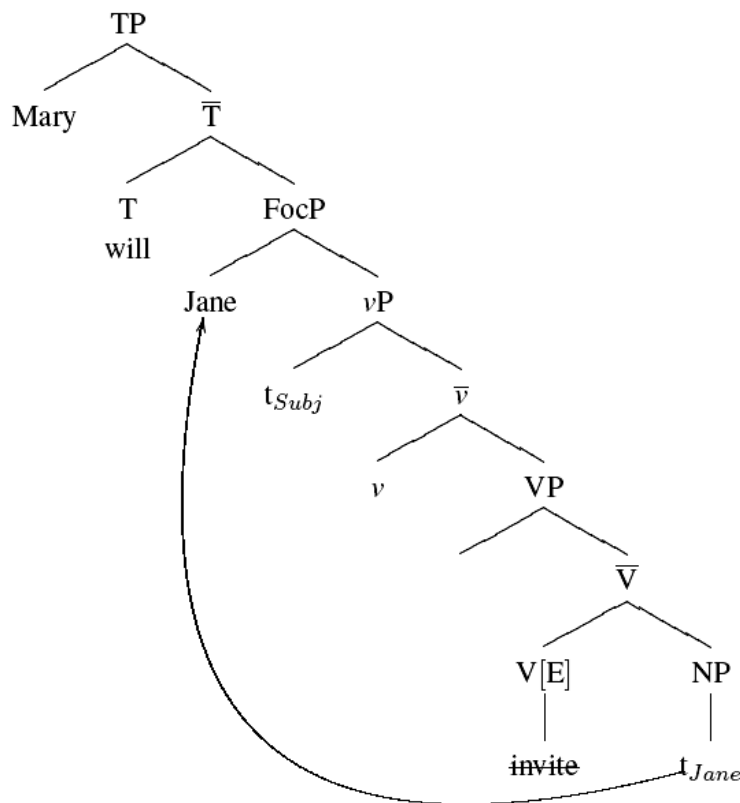

Alternatively, one could assume the outer specifier of vP to be the landing site for the Pseudogapping remnant (leaving phase-theoretical considerations aside for the moment). This configuration (based on Chomsky 2001, 2005) would then be as in (73) below.

Given that Chomsky (2005) suggests that the outer specifier of vP is an A' -position, derived by A' -movement, this A' -position could also capture the information-structural effects in Pseudogapping (i.e. the contrastiveness on the remnant).

However, depending on one's views on the deletion operation, more specifically, the size of the deletion site, the configuration with the Pseudogapping remnant in the outer specifier of vP could potentially cause a problem, since its presence in the vP layer is not compatible with the hypothesis that the vP is deleted in Pseudogapping (and not the VP ; cf. Merchant (to appear) for a recent implementation of this idea).

(73)

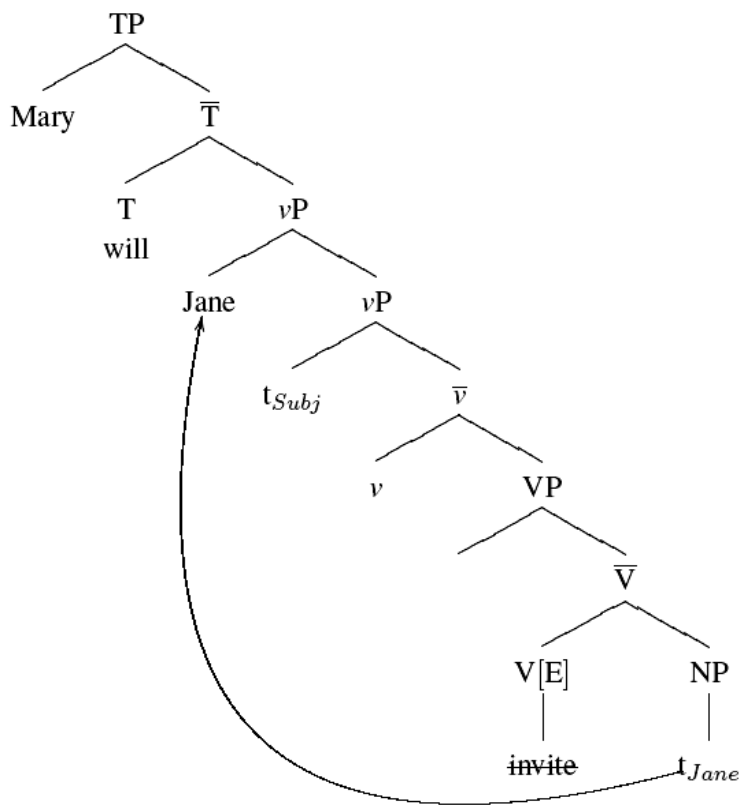

Thus, the structure illustrated below (74), invoking both the outer specifier of vP and the Focus projection above the vP layer, could also be a potential Pseudogapping configuration.

(74)

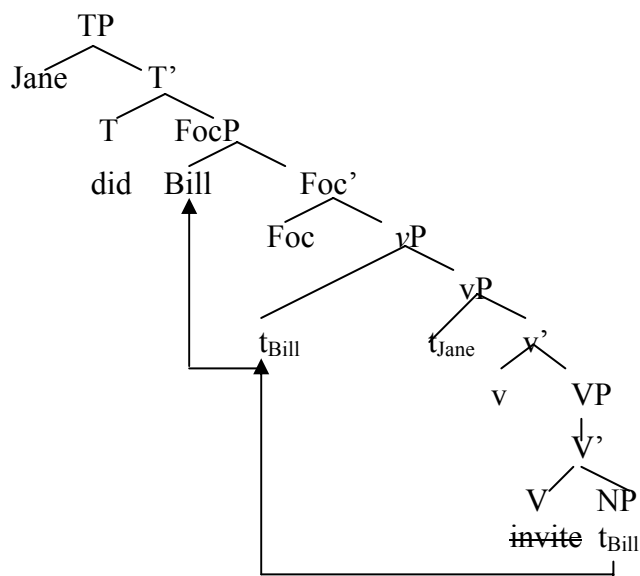

The configuration in (74) above receives a further justification apart from deletion, if one considers placing the derivation of Pseudogapping in a syntactic framework built on phases. As has already been mentioned in the section on the EPP, in a phase-based theory, there is the requirement that elements that need to be available for further computation need to move to the phase edge, i.e., in this case, the outer specifier of ν P.

If this outer specifier does not have A-bar-properties (contra Chomsky 2005), then the movement out of the phase, to the focus projection above the ν P layer, *must* proceed via this outer specifier position, caused by an edge feature (EF), or, as tentatively assumed in Chomsky (2005), an edge feature replacing the EPP.

Jayaseelan (2001), however, suggests a compromise with regard to the proposed structures in (72) to (74) above. Based on Rizzi's assumption (1997) that wh-movement targets the focus position in the CP domain, he contends (Jayaseelan 2001: 70) that the ν P layer should also receive a more articulate structure. Thus, the outer specifier of the ν P, which is, like the focus phrase, only generated if it is necessary, could actually be *replaced* with the focus phrase that is considered to host the moved Pseudogapping remnant.⁹³ In view of this analysis, the multiple specifier approach to the ν P level is also invalidated.⁹⁴

As Jayaseelan's (2001) analysis combines both the assumptions that there is a focus phrase in the syntactic derivation into whose specifier the Pseudogapping remnant can move, and the presumption in Chomsky's recent works (Chomsky 2001, 2005) that the outer specifier of ν P bears A-bar-properties, I will assume in what follows that the structure of the syntactic derivation is as suggested in (72) above.

The advantages of this approach are the following. Firstly, the structure with the separate focus phrase mirrors the analyses of focus movement in other languages. Secondly, it avoids the specific adoption of hypotheses that pertain to the phase theory of syntax (not least a clear statement regarding the exact status of the outer specifier of the ν P, which, to the best of my knowledge, is still a matter of debate). Thirdly, even within the phase theory of syntax, there is reason to believe that the Pseudogapping remnant has to leave the phase (if deletion of the

⁹³ This yields the immediate consequence that "cyclic wh-movement is seen to be focus-to-focus movement" (Jayaseelan 2001: 70).

⁹⁴ See Jayaseelan (2001: 70ff.) for further evidence supporting this claim.

entire vP is assumed, as in e.g. Merchant (forthcoming)). Naturally, the moved element would then move to a phrase outside of the vP phase, in essence, to the focus phrase.

6.6.2. Deriving direct object remnants and PPs in Pseudogapping

With regard to the derivation of the object remnants in transitive constructions, the direct object remnants in double object constructions, and the prepositional remnants in dative constructions, I presume that the movement of the respective elements, which are generated as VP complements, move to the specifier of the focus projection above vP , as illustrated in (76) for the Pseudogapping example given in (75).

(75) John will invite Susan, and Mary will Jane.

(76)

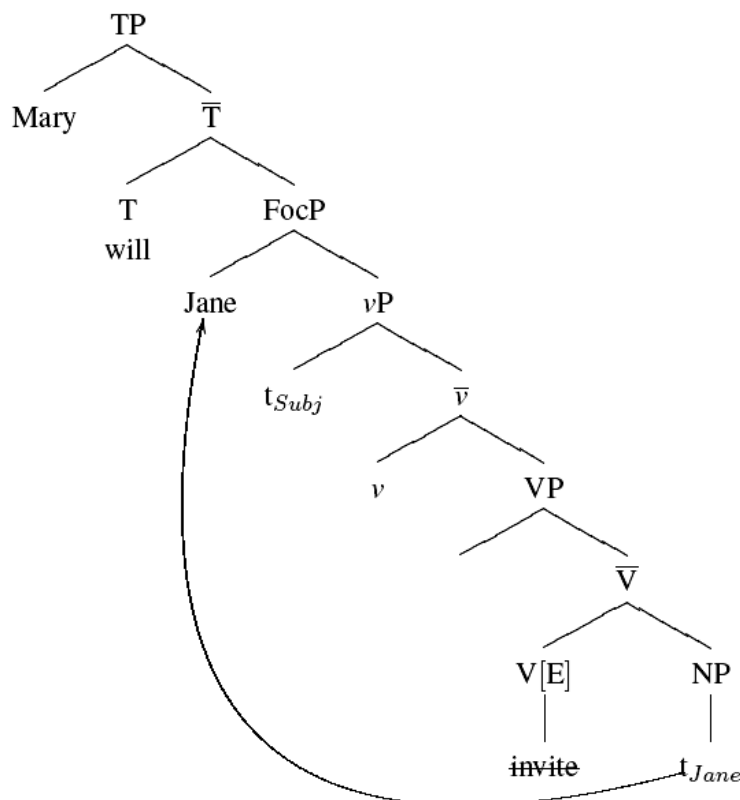

In the tree structure in (76), thus, there is only one instance of movement, which applies also in the other instances of Pseudogapping remnants mentioned above, namely, A-bar-movement from the complement position of VP into the [Spec,FocP] position.

Given that the movement assumed is A-bar-movement, this directly accounts for the distribution of parasitic gaps in the relevant cases, which are shown in the shaded rows in the table in (77) below. (In the second column, the ok and the star refer to the Heavy NP Shift (HNPS) account and the Object Shift (OS) account, in that order.)

(77)

Type of Remnant	Previous Accounts: HNPS/OS	Focus Movement	Parasitic Gaps?
object in transitive clauses (single remnant)	✓/✓	✓	yes/no
direct object remnant in double object constructions	✓/*	✓	yes
direct object remnant in dative constructions	✓/✓	✓	yes
indirect object in double object constructions	*/✓	✓	no
indirect object in dative constructions (the PP)	✓/*	✓	no (PPs)

In the following section, I will turn to the cases where no parasitic gaps seem to occur, an observation that, as noted in chapter 5, seems to point to an A-movement analysis (with the exception of PP movement).

6.6.3. Deriving indirect object remnants in Pseudogapping

As shown in the table in (77), some object remnants in transitive constructions do not license parasitic gaps (cf. (78) below, from Baltin 2003). Neither do indirect object remnants in double object constructions license parasitic gaps (cf. (79) below, from Takahashi 2004b).

(78) *Although John didn't kiss MARY_i without looking at e_i, he did SALLY_j without looking at e_j.

- (79) a. *Although John didn't give the tall boy a book, he did [the short boy]_i [without meeting e₁].
 b. *Although John didn't give the tall boy a book, he did [without meeting e₁] [the short boy]_i.

On the basis of these data, I suggest that in these cases, A-movement has indeed taken place, which would account for the absence of parasitic gap licensing. Consider the sentence in (80) (Lasnik 2001a: 120, fn. 10, his (ii)).

(80) Which men_i did the DA prove t_i to be there after each other_i's lawyers had sued p.g._i

This example is taken to be “quite degraded” (Lasnik 2001a: 120, fn. 10). In this case, presumably, there seems to have been an instance of A-movement, as indicated with the trace, prior to A-bar-movement. If this is the case, then, the derivation of Pseudogapping with indirect object remnants could proceed in similar fashion.

Recall the structure proposed in (76) above, here repeated as (81).

(81)

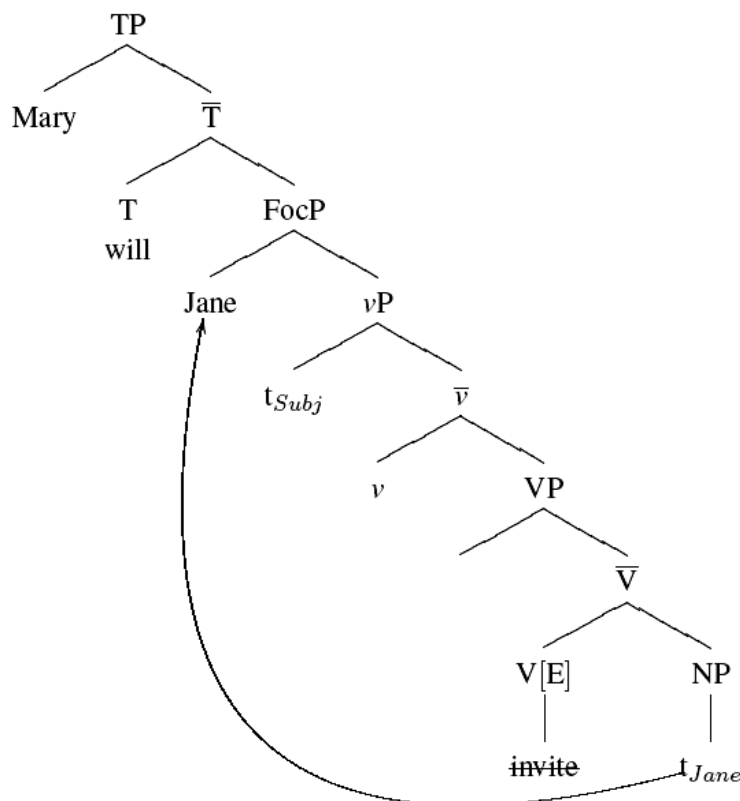

In this structure, it is not clear where an additional landing site could be created for A-movement, below the final position for the object, [Spec,FocP]. However, if we go back to Lasnik's (1995a, 1999a) original analysis, we could assume that the object is moved into a position between the two parts of the VP, the VP and the *v*P (cf. the discussion in chapter 4). Tentatively, one could assume a functional projection XP such as the one in (83) below for the sentence in (82).

(82) You won't believe me, but you will Bob.

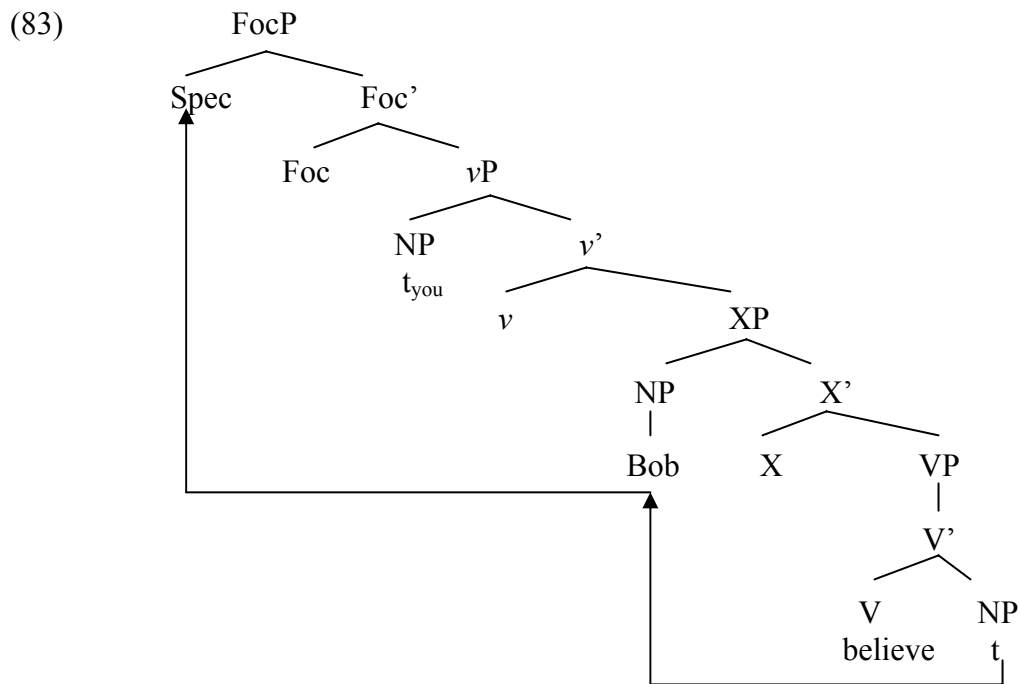

From this position onwards, the object could be moved via A-bar-movement to the specifier of the higher focus phrase. Alternatively, the XP position could also be the [Spec,VP] position, as suggested in Chomsky (2005) for ECM constructions (in (84)). In its adaptation to Pseudogapping, this is illustrated in (85) for the sentence in (82) above.

(84)

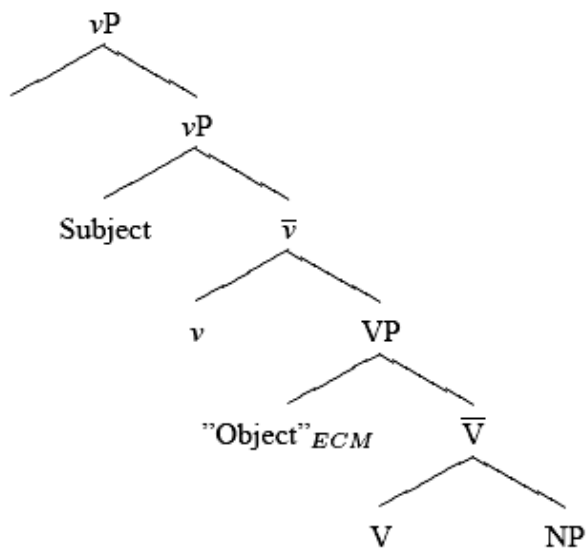

(85)

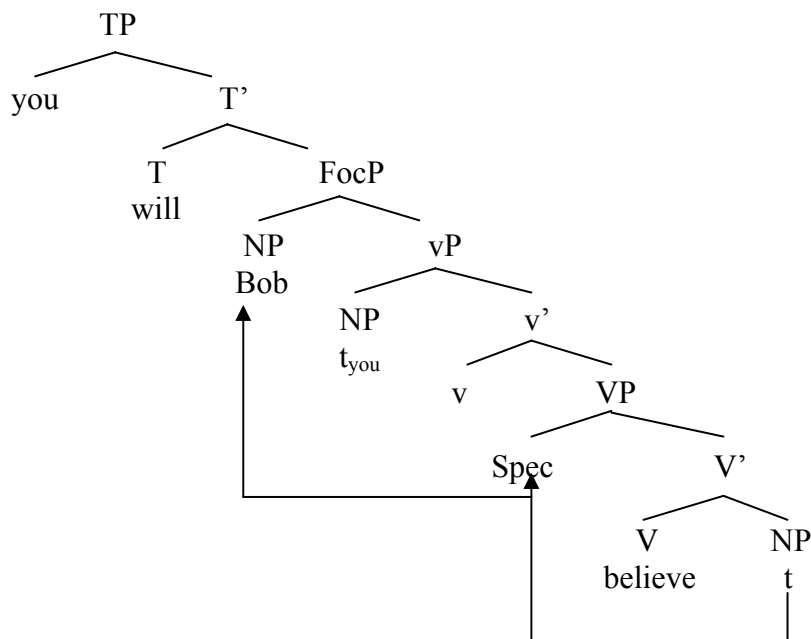

Thus, the failure to license parasitic gaps in Pseudogapping with indirect remnants might be accounted for with a successive movement such as the one outlined in (85) above.

In the remainder of this chapter, I will point out one difference that exists in the distribution of focus movement in English and Hungarian. Obviously, English does not have focus

movement as a rule, but if there is focus movement in ellipsis configurations, this movement does not seem to be due so much to exhaustivity as to contrastivity.

6.7. Exhaustivity and Contrast in Hungarian and English Focus Movement

According to Kíss (1998), there are two different types of foci, which she calls *information focus* (or *presentational focus*) and *identificational focus* (or *contrastive focus*). Although the assumption that there are two different foci is debated in the literature, in Hungarian, this distinction is supported by the different behaviour of the foci in question.

While the information focus can stay in situ, the identificational/contrastive focus needs to move to a specific position in the sentence, namely, a focus projection. The necessary requirement for triggering this movement is the requirement in (86) (repeated from section 6.3.3. above).

(86) *Identificational (=contrastive) Focus* (Kíss 1998)

An identificational focus represents a subset of the set of contextually or situationally given elements for which the predicate phrase can potentially hold; it is identified as the exhaustive subset of this set for which the predicate actually holds.

That the moved focus constituent always acquires an exhaustive reading is also pointed out by von Stechow (1991: 813), who cites an example from Szabolcsi (1980) (cf. (87)).

(87) a. [_F Máriát és Évát] szereti János.

[_F Mary-Acc and Eva-Acc] loves John-Nom.

‘Mary and Eva loves John.’

[i.e. ‘It is Mary and Eva that John loves’ – my paraphrase]

b. [_F Máriát] szereti János.

The two sentences in (87) are incompatible with each other, which suggests that “the NP in focus position is interpreted as an exhaustive list, i.e. as a strong version of *only*-NP. Thus, [_F Máriát és Évát] means Mary and Eva and no one else.” (von Stechow 1991: 813).

The problem arising from the situation in Hungarian is the following. If indeed not all types of focus undergo movement, as exemplified in Hungarian, the question is what actually triggers overt focus movement in English in elliptical configurations (leaving aside, for the moment, the dependency of the movement on deletion). Clearly, the exhaustivity requirement that is posited for the Hungarian focus movement seems too strong, as we will see in what follows.

6.7.1. Exhaustivity in Ellipsis Configurations

Following Kíss, there should be a requirement of exhaustivity on the Pseudogapping remnant, which would make the movement in English Pseudogapping similar to the focus movement operation in Hungarian.

However, this exhaustivity requirement poses a problem if we consider the Pseudogapping examples from above: exhaustivity, that is, the exclusion of all possible alternatives, is hard to establish. Consider, for instance, the sentences in (87) to (91).

(87) ‘Gerard *Logan!*’ The tall dog-walker, astounded, bending to look at me, knew me by sight, as I did him.

(Dick Francis, *Shattered*, 68)

(88) He asked curiously, ‘Which of all those sculptures in the book was the hardest for you to make?’ ‘The most difficult was the gypsy’s crystal ball.’ It surprised him, as it did most people.

(Dick Francis, *Shattered*, 226)

(89) John will select me, and Bill will you.

(Lasnik 1999a: 141)

(90) Mary hasn’t dated Bill, but she has Harry.

(ex. from Sag 1976, cited in Lasnik 1999a: 142)

(91) John invited Sarah, and Mary will Jane.

On an intuitive level, none of the sentences above conveys exhaustivity in the sense of excluding all other possible remnants. The kind of exhaustivity like the one found in the verbs such as *to marry* (in a monogamous society), for instance, does not seem to be present. Most of the examples, if continued with ‘... *and no one else*’ seem to gain an additional dimension, which is not felt to necessarily have been there without the added sentence ending. Thus, it seems that the contrastive focus said to be on the remnant in Pseudogapping does not obey the exhaustivity requirement that can be assumed for the Hungarian cases of focus movement. A potential way to align the two focus movements would presumably consist in contextually restricting the choice of remnants, so that in the given discourse situation, there is only one option taken from a set that is referred to. A second possibility, and the one I will adopt in what follows, is that the requirement driving overt focus movement is not so much exhaustivity but rather contrastivity, which is the predominant concept in elliptical structures.

6.7.2. The Non-Identity (Contrastiveness) Requirement

In contrast to Kíss (1998), Szendroï (2001) assumes that the requirement for overt focus movement in Hungarian is the fact that the moved element needs to be contrastive (rather than exhaustive). This hypothesis can easily be extended to elliptical structures in English (and, presumably, to ellipsis across languages). In the sentences above in (87) to (91), there is always a clear contrast, or a relationship of identity vs. non-identity of elements in the antecedent clause and the second conjunct. For instance, in the Pseudogapping case in (88) above, *most people* contrasts with *him* in the antecedent clause.

6.7.3. Implementing Contrast: The Contrastivity Feature

In order to implement this concept of contrast, I proposed in previous work of mine that a [+contrastive]-feature exists, on the element contrasted with its antecedent. This feature was intended to

- (i) capture the impossibility of deleting focused or new material, i.e. block deletion of a phrase when present in that particular phrase, and

- (ii) trigger movement of contrasted elements out of the phrase marked for deletion (cf. the discussion in chapter 8).

In a sense, then, movement based on contrastiveness is limited to cases of ellipsis. The advantage of a movement operation in terms of contrast is that while focus movement can proceed quite independently from ellipsis (as shown in the Hungarian cases above, or in English cleft sentences), the close link to the antecedent, which lies at the heart of the contrastive feature, is crucial only in ellipsis processes, where contrastive material needs to be moved out of clauses that are specified for deletion.

On the other hand, it would be less than economical to introduce yet another feature into the syntactic derivation if there is another feature that is more parsimonious and similar in kind, that is, the focus feature F. As we have seen above, this feature figures prominently in the semantic derivation of elliptical structures. In a sense, then, the focus feature could replace the [+contrastive] feature, if it is coupled with the requirement that focused constituents (or elements) may only move in English once there is an E-feature in the structure, which triggers phonological deletion.

6.8. Conclusion

I conclude thus on the basis of the discussion provided in this chapter that English Pseudogapping can, and should, be analysed as involving focus movement, triggered by a focus feature F. To qualify this assumption further, and to show how the focus interacts with ellipsis, I will take a closer look at the semantics of both focus and ellipsis in the next chapter.

7. The Semantics of Focus and Ellipsis

This chapter is intended to give a small overview of the semantics of focus and the licensing of deletion. Since Pseudogapping involves syntactic focus movement, the relevant conditions for the semantic licensing have to be addressed. However, the discussion of this topic here is by no means conceived to be exhaustive, but is rather intended to illustrate which general lines of reasoning have been proposed in the literature so far – to the best of my knowledge –, and to provide some suggestions as to which account might be most adequate for Pseudogapping (and, potentially, other ellipsis types). The chapter is structured as follows. First, I will present the main arguments of the alternative semantics approach, in the versions presented in Rooth (1985), and Rooth (1992a,b), showing its benefits, and pointing out potential problems with respect to the focus structure of ellipsis. I will then proceed to a discussion of the revision of Rooth's (1985) approach made in Kratzer (1991). Kratzer, addressing the VP ellipsis problem, provides a solution including variable assignments. I will maintain that an analysis along these lines does not only account for the semantic restrictions in VP ellipsis, as argued for by Kratzer, but can also be extended to the Pseudogapping case and other elliptical structures. I will conclude the chapter with a proposal as to how such an approach might look like.

7.1. Focus on the Remnant: The Alternative Semantics Approach

Rooth (1985) develops an *in situ* theory of focus, arguing against the LF focus movement approach. In the latter type of analysis, in order to account for the scopal properties of focus particles such as 'only', an LF is assumed in which a focused phrase moves from its base position, ending up in a position next to 'only'. The moved phrase leaves behind a (bound) variable. By contrast, in the type of analysis suggested in Rooth (1985, 1992), no focus movement at the LF level is assumed, hence, the postulate of a bound variable in the position of the focused phrase is rendered obsolete. To account for the interpretation of focus *in situ*,

Rooth (1985, 1992a, b) suggests that focused constituents introduce sets of alternatives. This is implemented as follows.

Each intensional logic expression receives two different denotations. One denotation is the ‘ordinary semantic value’ (the usual denotation), and the second is the ‘focus semantic value’, “the set of alternatives from which the ordinary semantic value is drawn” (Rooth 1992a:76), thus expressing the contribution of focus. Thus, for a given semantic object α , the ordinary value is $\|\alpha\|^o = \{\alpha\}$. The focus semantic value $\|\alpha\|^f$ includes the alternatives of α , e.g. $\alpha_1, \alpha_2, \alpha_3$, etc., i.e. $\|\alpha\|^f = \text{ALT}(\alpha) = \{\alpha_1, \alpha_2, \alpha_3, \dots\}$. A concrete example (where focus is triggered by the presence of the focus particle ‘only’) is given in von Stechow (1991: 814):

(1) John only introduced $[\text{Bill}]_F$ to Sue.

The focus semantic value of $[\text{Bill}]_F$ includes all possible, contextually salient individuals. With the set of individuals being $\{\text{Bill}, \text{Sue}, \text{Ede}\}$, for instance, nine combinations are possible. The alternatives in (2) show the set of alternatives we obtain for the sentence with focus on $[\text{Bill}]_F$ (von Stechow 1991: 814).

(2) For the structure $\|\text{introduced } [\text{Bill}]_F \text{ to Sue}\|$ we obtain:

$\{\|\text{introduced Bill to Sue}\|, \|\text{introduced Ede to Sue}\|, \|\text{introduced Sue to Sue}\|\}$.

According to Rooth (1992a:76), “the ordinary semantic value is always an element of the focus semantic value”. While this definition may be unproblematic for focus with focusing adverbs such as ‘only’, a potential problem arises with cases where focus seems to be motivated by contrast.

(3) An $[\text{American}]_F$ farmer was talking to a $[\text{Canadian}]_F$ farmer...

(4) Jóhn hit Bíll and then hé hit hím.

In (3) and (4), focus arises because two NPs are in contrast with each other. As a first approach, Rooth (1992a:81) formulates the following definition of contrasting phrases:

(5) Construe a phrase α as contrasting with a phrase β , if $\|\beta\|^0 \in \|\alpha\|^f$.

An additional requirement for the interpretation of contrastive focus is that $\|\beta\|^0 \neq \|\alpha\|^0$.

Applied to the sentence in example (3) above, we obtain the following for α being $[_N[_{N'}[_{F} \text{American}]]_F \text{ farmer}]$ and the contrasting phrase β being $[_N[_{N'}[_{F} \text{Canadian}]]_F \text{ farmer}]$ (Rooth 1992a:81, his (15)):

(6) $\|[_N[_{N'}[_{F} \text{American}]]_F \text{ farmer}]\|^f = \{\lambda x[P(x) \wedge \mathbf{farmer}(x)] \mid P:E \rightarrow \text{propositions}\} (= \|\alpha\|^f)$

$\|[_N[_{N'}[_{F} \text{Canadian}]]_F \text{ farmer}]\|^0 = \{\lambda x[\mathbf{Canadian}(x) \wedge \mathbf{farmer}(x)]\} (= \|\beta\|^0)$

The two foci are connected as follows. As required in (5), $\|\beta\|^0 \in \|\alpha\|^f$ holds, since ‘Canadian farmer’ is a property of the form ‘ P farmer’. Rooth thus concludes that the focus semantic value of $[_N[_{N'}[_{F} \text{American}]]_F \text{ farmer}]$ constrains the choice of the contrasting phrase. The second focus works in exactly the same way: if α is now $[_N[_{N'}[_{F} \text{Canadian}]]_F \text{ farmer}]$, and β is $[_N[_{N'}[_{F} \text{American}]]_F \text{ farmer}]$, $\lambda x[\mathbf{American}(x) \wedge \mathbf{farmer}(x)]$ is a property of the form $\lambda x[P(x) \wedge \mathbf{farmer}(x)]$.

7.1.1. The \sim Operator

Rooth introduces a Focus Interpretation Principle (Rooth 1992a:86), given in (7), which is incorporated in a focus interpretation operator, the \sim operator.

(7) *Focus Interpretation Principle*

In interpreting focus at the level of a phrase α , add a constraint that:

(*contrasting set*) $\Gamma \subseteq \|\alpha\|^f$, or

(*contrasting individual*) $\gamma \in \|\alpha\|^f$.

Γ is a variable with the type of a set of objects matching α in type, and γ is a variable matching α in type.

The \sim operator is introduced in the syntactic structure at the level at which the interpretation of focus takes place.⁹⁵ In the farmer example the squiggle operator introduces a second argument, a property variable P (= γ in the Focus Interpretation Principle). The second N' containing the adjective 'Canadian' is co-indexed with the property variable assigned to the first N', the 'American farmer'. The co-indexation expresses a relation that is taken to express identity of properties. Schematically, this can be represented as in (8) (Rooth 1992a:86, his (28)):

(8)

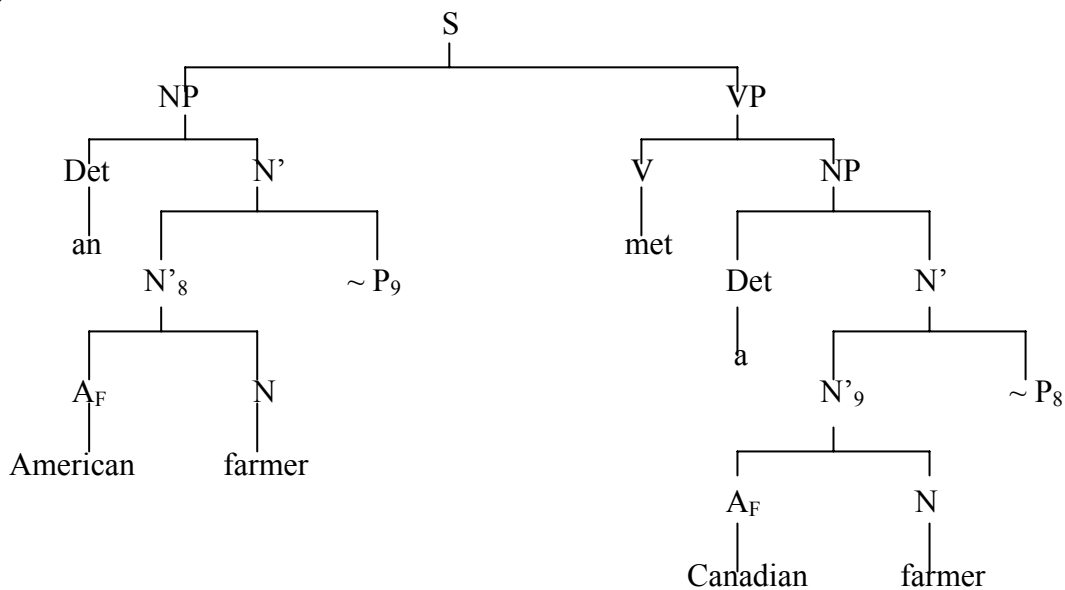

In summary, Rooth claims that the Focus Interpretation Principle could be restated as simple as follows: “Adjoin an operator $\sim v$ to a phrase α in LF, where v is a variable with either the same type as α (individual case), or the type of a set of objects with the same type as α (set case).” (Rooth 1992:95).

The approach suggested in Rooth can be adapted to Pseudogapping as follows in the next section.

⁹⁵ Note that Rooth (1992a:87) does not commit himself with regard to the presence of the variable created by the \sim operator at a strictly syntactic level – it could also be present only at the level of interpretation. However, he states in a footnote (Rooth 1992:114): “To the extent that there is a correlation between the scope of the \sim operator and the phonological domain of prominence for a focus, as there surely is, a theory of focus realisation should enforce the correlation. If the \sim operator were present only in LF, it could not serve the purpose of delimiting a phonological domain of prominence. Perhaps the solution is simply that it is present at other levels also, including the input to the phonological interpretation.” I will come back to this point.

7.1.2. The Focus Structure in Pseudogapping

Takahashi (2004b) provides an example of how to implement Rooth's (1992a, b) analysis for Pseudogapping.

For the Pseudogapping example in (9) (Takahashi 2004b), the focus configuration can thus be derived as in (10) and (11) (also from Takahashi 2004b), with the subscript VE indicating the elided V, and VA indicating the antecedent V.⁹⁶

(9) John will select Sue, and **BILL_F** will ~~select~~ **MARY_F**.

(10) a. elided constituent α : $\langle_{VE} \text{select} \rangle$

b. antecedent constituent β : $[_{VA} \text{select}]$

c. for every assignment function g $\|\text{select}\|^g = \|\text{select}\|^g$

(11) a. $[_{TP1} \text{John will select } t_1 \text{ Sue}_1]$, and $[_{TP2} \text{BILL}_F \text{ will } \langle_{VPE} \text{select } t_2 \rangle \text{ MARY}_{F,2}]$.

b. constituent β : $\text{BILL}_F \text{ will } \langle_{VPE} \text{select } t_2 \rangle \text{ MARY}_{F,2}$

$\|\text{BILL}_F \text{ will select MARY}_F\|^o = \text{Bill will select Mary}$

$\|\text{BILL}_F \text{ will select MARY}_F\|^f = \{x \text{ will select } y: x, y \in D_e\}$

c. antecedent LF γ

$\|\text{John will select Sue}\|^o = \text{John will select Sue}$

d. $\text{John will select Sue} \in \{x \text{ will select } y: x, y \in D_e\}$

As we have seen in the final section of the previous chapter, it is important that the relationship of contrast be established between the antecedent and the remnant which remains in Pseudogapping. In (11), this condition is ensured with the computation of alternatives: since in (11c), the ordinary value of the antecedent *John will select Sue* is in the focus value of the remnant, the corresponding Pseudogapping example can be derived.

This general contrast condition, which covers the Pseudogapping cases as well, can also be stated as in (12) (Johnson 2001: 453, his (52)).

⁹⁶ Note here that crucially, the definition of the elided constituent α actually depends on the analysis proposed (Howard Lasnik, p.c.). For Takahashi (2004b), for instance, as indicated in (10), the elided constituent is the VP.

- (12) a. An elided VP must be contained in a constituent which contrasts with a constituent that contains its antecedent VP.
- b. α contrasts with β iff
- (i) Neither α nor β contain the other, and
 - (ii) For all assignments g , the semantic value of β with reference to g is an element of the focus value of α with reference to g .
 - (iii) The focus value of $[\xi \dots \gamma \dots]$, where γ is focused, is $\{\|\Phi\|: [\phi \dots x \dots]\}$, where x ranges over things of the same type as γ and the ordinary semantic value of ξ is identical to $\|\Phi\|$ except that x replaces γ .

Here, in (12bii) it is ensured that the values of the indices are assigned the same values, if they are in an antecedent – elided clause relationship, and by means of (12biii), they are assigned different values if they are indices on focused items.

7.2. The Treatment of Alternatives

Johnson's (2001) definition essentially treats two distinct problems at the same time. In Kratzer (1991), for instance, it is pointed out that Rooth's (1985) account, with its inherent computation of alternatives, fails to provide the correct set of alternatives in ellipsis. As we will see in the following section, Kratzer (1991) proposes to remedy this problem with the assignment of indices that receive the same value in ellipsis clauses, thus being in line with Johnson's (12bii) above. In Gengel (forthcoming) I suggested that this indexing process can equally be used to establish the contrast between the remnant and the antecedent in Pseudogapping, which is anticipated in Johnson's (12biii).

7.2.1. The Ellipsis Problem (Kratzer 1991)

Recall that in Rooth's theory of focus, focus is computed by a procedure that gives any intensional logic expression a "normal" denotation, and a second denotation that incorporates the focus structure. To this end, a focus feature F is assumed, and focused constituents are

marked with this feature in the syntax.⁹⁷ These features are then used to yield the second denotation mentioned above. We have seen that the focus feature determines a set of alternatives (cf. the discussion of example (2) above).

Kratzer (1991) points out that VP ellipsis poses a challenge with respect to the computation of alternatives. For instance, in a sentence such as in (13) (Kratzer 1991:830) the Roothian focus analysis generates too many alternatives (cf. (14), if the alternatives are taken from the set {Block Island, Elk Lake Lodge, Tanglewood}).

(13) I only _{VP}[went to _F[Tanglewood]]because you did _{VP} [e].

(14){||go to Tanglewood because you went to Tanglewood||, ||go to Tanglewood because you went to Block Island||, ||go to Tanglewood because you went to Elk Lake Lodge||, ||go to Block Island because you went to Block Island||, ||go to Block Island because you went to Elk Lake Lodge||, ||go to Block Island because you went to Tanglewood||, ||go to Elk Lake Lodge because you went to Block Island||, ||go to Elk Lake Lodge because you went to Elk Lake Lodge||, ||go to Elk Lake Lodge because you went to Tanglewood||}
(Kratzer 1991: 830)

The intended context for this example, however, is the one in (15) (Kratzer 1991:830).

(15) Imagine now you are angry at me and start voicing the following accusations. “What a copy cat you are! You went to Block Island because I did. You went to Elk Lake Lodge because I did. And you went to Tanglewood because I did.” I feel you exaggerate and reply [(13)].

As VP Ellipsis entails a process of reconstruction, which is taken to copy the missing VP from the antecedent VP, after reconstruction the sentence in (13) is as in (16).

⁹⁷ Both Rooth (1985) and Kratzer (1991) use the term *surface structure* (i.e. the syntax). In current terminology, the F-marking could also take place in the numeration already, and the F-marked elements could then come into the syntax already specified as F-marked (and, presumably, F-indexed, cf. Kratzer 1991).

(16) I_F[past_{VP}[only_{VP}[VP[go to_F[Tanglewood]]] because you did_{VP}[go to_F[Tanglewood]]]]].

Thus, in the case at hand, the only valid alternatives are those where the two elements of the antecedent and the elided clause are the same. Hence, we only obtain the following alternatives ((17), Kratzer 1991:830):

(17) {||go to Block Island because you went to Block Island||, ||go to Elk Lake Lodge because you went to Elk Lake Lodge||, ||go to Tanglewood because you went to Tanglewood||}

Kratzer (1991) suggests a modification of Rooth's (1985) account to overcome the problem in VP Ellipsis. She assumes that the F-marked constituents (that are marked at the Surface Structure, i.e. at the syntactic level) also bear an F-index, where no two constituents may bear the same F-index (the 'novelty condition' of F-indexing, Kratzer 1991: 831). Following Rooth's account in keeping the two denotations of the logical form of a given sentence, Kratzer then modifies the treatment of the F-marked constituents, which are now translated as designated variables, as defined in (18) and (19) (Kratzer 1991: 831), where α is the LF phrase and α' the usual translation.

(18) Whenever α is an F-marked constituent bearing the F-index n and α' is of type τ , then α'' is the n th designated variable of type τ .

In Rooth's (1985) terms, α'' is the set of objects matching α' in type, if α bears the feature F.

(19) Denotations for the designated variables

$$\|\mathbf{V}_{\tau,n}\|^{g,h} = h(\mathbf{V}_{\tau,n})$$

The intensional language used is then modified to accommodate these designated variables $\mathbf{V}_{\tau,n}$ as well as two variable assignments, ordinary variable assignments and distinguished variables. All meaningful expressions are assigned intensions relative to these two variable assignments. In (19), g is an ordinary assignment and h is a distinguished assignment.

This particular variable assignment procedure allows Kratzer (1991) to assume that “variable assignments assign the same values to different occurrences of the same variable” (Kratzer 1991:832). This assignment procedure is what ultimately accounts for the correct derivation of alternatives in VP Ellipsis, i.e. the set of alternatives in (17), shown with the indexing in (20).

(20) $\lambda v_{e,1}$ [because'(go'(V_{e,2})(v_{e,1})) (go'(V_{e,2})(you'))]

We see that the suggested variable assignment causes the two occurrences of F [Tanglewood] to have the same values, which then yields the desired set of alternatives in (17).

In her theory, Kratzer (1991:833) has to assume that a configuration such as the one in (20) is derived via a copy operation taking place after syntax. Otherwise, the novelty constraint on F -indexing (i.e. no two variables should bear the same index) would prohibit the occurrence of the same designated variable. I will discuss this in more detail in the next section.

7.2.2. Indices and Alternatives in Ellipsis Structures

We have seen in the previous section that the variable assignment process proposed by Kratzer provides a means to assign indices to the variables created by the introduction of focus. For the case of bound variables, as in VP ellipsis, this indexing process is crucial to yield the correct set of alternatives. In what follows, I will show that this indexing plays a vital role in all cases of ellipsis, which is, as mentioned above, also expressed in Johnson's (12biii).

Consider the Pseudogapping example in (21).

(21) John invited Bill more often than Bill did him.

Here, following Rooth's discussion of ellipsis examples in Rooth (1992), there are at least two possible LF structures with focus:

- (22) a. John invited Bill more often than Bill did [him]_F.
b. John invited [Bill]_F more often than Bill did [him]_F.

While the focus in the first conjunct may be debatable, the second focus on [him]_F is quite uncontroversial. This view is corroborated by the strong marginality (if not ungrammaticality) of (23).

- (23) *John invited him₁ more often than Bill did him₁.

The only way to make (23) acceptable is if *him* in the antecedent and *HIM* in the ellipsis clause are not co-indexed, as in (24) (as indicated by the focus on the object in the ellipsis clause).

- (24) John invited him₁ more often than George did HIM₂.

Thus, there seems to be a relationship of non-identity at work in ellipsis clauses, which can be captured with an indexing process.⁹⁸ Given that this indexing process could establish the necessary contrast between the two objects in the sentences above, the question arises whether the recourse to alternatives (or sets of alternatives), a view adopted by both Rooth and Kratzer, is really necessary. In Rooth (1992a), the focus interpretation principle (cf. (7) above) introduces a variable (either a contrasting set or a contrasting element), with the \sim operator introducing the set of alternatives. In a sense, though, the reference to alternatives could, in principle, be abandoned, if the \sim operator is treated as an operator which binds focus variables (Rooth 1992a: 115, with reference to Kratzer 1991).

⁹⁸ This non-identity requirement (henceforth: contrastiveness requirement) is not only valid for Pseudogapping. Consider the following Sluicing (i), Gapping (ii), and NP Ellipsis examples (iii):

- (i) Mary bought something, but I don't know what.
(ii) Heather read more books than Terry magazines.
(iii) I bought the red coat, and you bought the blue (one).

In all these examples, we find that there is one element – the element not targeted by ellipsis – being in contrast to its corresponding element in the first clause, e.g. *something* vs. *what* in (i), *books* vs. *magazines* in the Gapping example in (ii) (as well as the contrastive subjects, *Heather* vs. *Terry*), and *red* vs. *blue* in the NP Ellipsis in (iii).

Thus, we may either assume a \sim operator with the corresponding variables on the syntactic level, or a variable assignment process as suggested in Kratzer (1991), to arrive at the correct indexing of focused elements, without having to invoke alternatives as such.⁹⁹

At least for elliptical structures, this does not seem to be an unwelcome result, since the exclusion of undesired alternatives (as in the VP ellipsis case discussed in Kratzer (1991)) is no longer a problem. Moreover, the contrast perceived in the ellipsis examples given above need not be explicitly F-marked on both elements, as illustrated in the example in (22a). Furthermore, according to Rooth (1992a), the focused element in the second clause should be an element of the alternative set of the focused element in the first clause. Given that the first element does not necessarily bear a strong focus, the question is whether there is the need for an alternative set at all. I will claim in what follows that the crucial information needed for the element in the second clause to bear focus is simply the information that it is in contrast to the (syntactically) corresponding element in the antecedent clause, a requirement which renders the process of computing (sets of) alternatives secondary, if not obsolete.

7.2.3. F-Marking and F-Indexing in Syntax

Kratzer (1991) and Rooth (1992 a,b) follow the traditional assumption (e.g. Jackendoff 1972) that focused constituents are F-marked at the level of syntactic structure. This F-marking is then passed onto the level of logical form, i.e. to semantic interpretation. In addition, Kratzer assumes an F-indexing process that takes place in syntax, which then accounts for the different variable assignments at the level of semantic interpretation.

In cases of ellipsis, an observation that generally seems to hold is that there is a relationship of identity vs. non-identity of elements in the antecedent clause and the second conjunct, as already mentioned above, and suggested in e.g. Rooth (1992 a,b) with his remarks on a potential link between ellipsis and contrastive focus. In the account that I will propose below, I will capitalise on this property, and suggest that it is precisely this property which is expressed in Kratzer's (1991) F-indexing mechanism.

⁹⁹ As I am interested only in the derivation of elliptical structures, I will not discuss possible consequences of this hypothesis for other instances of focus.

Let us first look at the VP ellipsis case again. According to Kratzer, the novelty constraint on F-indexing prohibits the assignment of two identical indices to different variables. Since the F-index seems a process strictly related to focus, however, I believe that this process could be linked to contrast (i.e. identity vs. non-identity of elements/variables). Suppose now that this F-indexing is a process superseding the process of F-marking.

With regard to deletion, this F-indexing information serves as input to the E-feature (which is already introduced in the numeration), as I will argue in this dissertation, and the E-feature is only able to delete elements that are not specified as being contrastive. Especially if it is present at the syntactic level (and not only at LF), F-indexing could indeed provide this kind of information on contrast, which then serves as a prerequisite for optional phonological deletion.

Thus, for VP ellipsis, we could assume that there the focus values are set such that the remnants (e.g. *Tanglewood* in Kratzer's example) bear the same index, thus marking them as non-contrastive and potentially available for deletion. To avoid the presence of a (semantically) focused element in the ellipsis domain, we could also stipulate that if the F-indexing of two elements yields identity, there is no syntactic F-marking at all, i.e. no focus, which then allows syntactic deletion of a non-contrastive, non-focused element in VP ellipsis (see the chapter on deletion for further discussion). Therefore, the novelty constraint on F-indexing postulated by Kratzer does not necessarily hold in VP ellipsis cases. Put another way, if the novelty constraint is not fulfilled, the relevant structure can be – and indeed often is – elided.

On the other hand, in other types of ellipsis, there is a clear relationship of non-identity of variables with respect to the antecedent clause, or, according to Kratzer, the two elements would be assigned different F-indices. Hence, data from other elliptical structures (cf. e.g. the examples in footnote 89 above) suggest that it is indeed possible to extend Kratzer's (1991) account for VP Ellipsis to other cases of ellipsis if one includes the requirement that in other cases of ellipsis, there are no two occurrences of the same variable, i.e. never the same F-indices. In fact, Kratzer herself (1991: 833) points out that “the ‘novelty’ constraint for F-indexing wouldn't (and shouldn't [...]) allow the appearance of two occurrences of the same designated variables”. Thus, Kratzer's novelty requirement on F-indexing would be a very

natural way to account for the fact that the remnant and the antecedent need to be contrastive in Pseudogapping and other types of ellipsis.

On the basis of this observation, let us now turn to the syntactic side of the problem. So far, we have established the impact that the relevant semantic conditions holding for ellipsis might have in the syntactic derivation of elliptical structures.¹⁰⁰ As I suggested in this dissertation and earlier work, in contrast to the VP ellipsis cases with bound variables, there is a focus movement process taking place in the syntax in the other ellipsis cases, with the semantic background as sketched in what follows.

Suppose that the F-indexing process marks the two remnants as bearing different F-indices, which is a straightforward conclusion from Kratzer's (1991) novelty constraint on F-indexing. If the two indices are now different, the two elements can be said to be contrastive (irrespective of their focal properties). As a result, they are F-marked.

As I have argued above for VP ellipsis, the F-indexing process seems to entail the F-marking process, at least in the elided sentences. Thus, one could argue that any F-marking (possibly also incorporating the concept of *given* vs. *new* information, as suggested in Merchant's (2001) definition of the E-feature) renders a syntactic element capable of undergoing focus movement. However, this claim would be too strong, as it is still a matter of debate whether focus (expressed by F-marking) is always contrastive. For the purposes of this dissertation, I will thus follow the hypothesis that F-indexing is the more important process, implying the contrast necessary for the derivation of elliptical structures.

In order to show that the underlying principle triggering focus movement in English is the notion of contrast, consider the two instances where focus movement can be assumed in English, in cleft sentences (as in (25), Kiss 1998: 249), and, according to my analysis, in Pseudogapping (as in (26), Lasnik 1999a: 141)) and other elliptical structures (cf. also Gengel 2006d, e, a.o.).

¹⁰⁰ One might actually argue at this point that the syntactic impact of the F-indices in VP ellipsis need not be stipulated, since no syntactic movement takes place in these cases. This is correct, and there is the possibility to relegate the identity question to LF, as in Kratzer (1991). However, for the sake of uniformity of argument, I will follow the hypothesis that in all instances of ellipsis, the syntactic effects are the same.

(25) It was a hat that Mary picked for herself.

(26) John will select me, and Bill will you.

The sentence in (25) could be paraphrased such that Mary picked a hat out of a set of other pieces of clothing (cf. K iss 1998: 249), hence, some contrast seems to be implied, as a potential follow-up to (25) could be e.g. “... and not a scarf”.¹⁰¹

In ellipsis, the contrast may be established somewhat differently, without recourse to alternative sets, as argued above, but still, there is a clear contrast between the object in the first clause (*me*) and the object remnant of the second conjunct (*you*) in (26) (see also the discussion in Rooth (1992 a,b) on contrastive focus in ellipsis, and the discussion of examples (23) and (24) above). Thus, it seems fairly clear that there is some notion of contrast involved in the derivation of both cleft sentences and ellipsis structures.

For the syntactic derivation, however, we need to assume that there is an interaction between ellipsis and contrast, since in (26), there might be a focus on ‘me’ (analogous to the example in (22) above, here repeated as (27)), but the object in the first clause of (27b) does not undergo focus movement, nor would there be any reason to assume focus movement of the object in (28).

(27)a. John invited Bill more often than Bill did [him]_F.

b. John invited [Bill]_F more often than Bill did [him]_F.

(28) John invited [Bill]_F.

I will argue in this dissertation that focus movement is only an option if a contrast has been established between corresponding elements in the syntactically parallel structure, and an E-feature (responsible for the actual phonological deletion) is present in the relevant part of the structure, mostly in the second conjunct, as in the examples provided above.

¹⁰¹ There is also the question of exhaustivity in cleft sentences, which I will not pursue here. The exhaustivity requirement implies that Mary only picked a hat in (24) and nothing else. More often than not, though, it seems to be the case that there is indeed a set from which something is taken, i.e. a contrast is given, and, from that perspective, exhaustivity is an additional requirement. For a more detailed discussion of this problem see Gengel (2006e).

The interaction that I assume between the F-indexing process and the E-feature also incorporates the dual nature that Rooth (1992b) proposed for his \sim in the licensing of ellipsis, i.e. the observation that it licenses both (contrastive) focus and ellipsis, as we will see in what follows. However, as I will show in the course of this dissertation, an analysis where this double role is implemented with two distinct processes or features has the advantage of incorporating the syntactic constraints that hold in the derivation of elliptical structures, which are difficult to capture with the exclusively semantic definition of the \sim operator.

7.3. Licensing Deletion

In this section, I will show how the prerequisite on VP deletion, that is, the identity between the first VP in the antecedent and the deleted VP, can be established. In its essence, I will follow Merchant's (2001) analysis of the E-feature. In order to motivate this approach to deletion, I will first discuss the identity relation, and then turn to the implementation of this identity relation via the E-feature.

7.3.1. Deaccenting and Deletion

In the literature, for instance, in Tancredi (1992) and Rooth (1992a), there is often a link assumed that holds between deaccented structures and elliptical structures, such as the ones in (29) and (30) below (taken from Merchant 2001: 15, 17, his (12a) and (18a)), even though they are not synonymous.

(29) Abby was reading the book while BEN *was reading*. (*Deaccenting*)

(30) Abby was reading the book while BEN was. (*Ellipsis*)

As a consequence, the conditions that license the deaccenting and the ellipsis cases are considered to be quite similar, with the conditions on ellipsis often treated to be a subpart of the conditions on deaccented structures (cf. Tancredi (1992) and Rooth (1992a)). Moreover, these conditions are related to other, more general, requirements that concern the distribution of focus. The strategy often pursued in the literature has thus been to define these focus

requirements such that they also cover the distribution of ellipsis or deaccented structures. As we will see below, this observation also figures prominently in Merchant's (2001) analysis, and one that I will also adopt in my own account of Pseudogapping and other elliptical structures.¹⁰²

Despite the apparent similarities between the licensing conditions on deaccented structures and elliptical structures, it is generally agreed that ellipsis is subject to an additional requirement. This prerequisite for the licensing of elliptical configurations is usually considered to be structural. In the next section, I will discuss this structural condition, before moving on to Merchant's (2001) proposal.

7.3.2. The Isomorphism Condition

The additional requirement that applies to ellipsis, in contrast to mere deaccenting, structures, is mostly considered to be a structural isomorphism condition. In this section, I will discuss this condition in some detail, summarising the arguments in favour and against it on the basis of Merchant's (2001) analysis.

Essentially, a structural isomorphism condition requires the presence of an antecedent that has the same syntactic structure as the elided constituent. Merchant (2001: 17) notes that the requirement that the two structures be identical in meaning is secondary in this structural isomorphism approach, presumably since structural identity implies a similar interpretation. This 'isomorphism condition on ellipsis', as Merchant (2001: 17) calls it, thus establishes a direct relation between the availability of a structurally identical antecedent and the ensuing possibility of eliding phrases corresponding to this antecedent in structure.

This isomorphism condition is fulfilled in the example given in (3) below, with the relevant tree structure in (5) (Merchant 2001: 17f., his (18a) and (20)). As can be seen in the syntactic structure in (33), VP_A (i.e. the antecedent) has the same syntactic structure as VP_E (the elided constituent). Thus, deletion is legitimate in the sentence in (31).

¹⁰² For similar approaches in the literature see, for instance, Rooth (1992a, b), Schwarzschild (1999), and Gergel, Gengel and Winkler (2007).

(31) Abby was reading the book while BEN was.

In the deaccenting example given in (32), on the other hand, repeated from (29) above, the isomorphism condition is not met. The structure in (34) below shows that if *read* is treated as being used with an implicit object, which therefore is not present in the syntactic structure, VP_A does not have the same structure as VP_E. Given this mismatch in the structural configuration, deletion in (32) is ruled out.

(32) Abby was reading the book while Ben was reading.

(33)

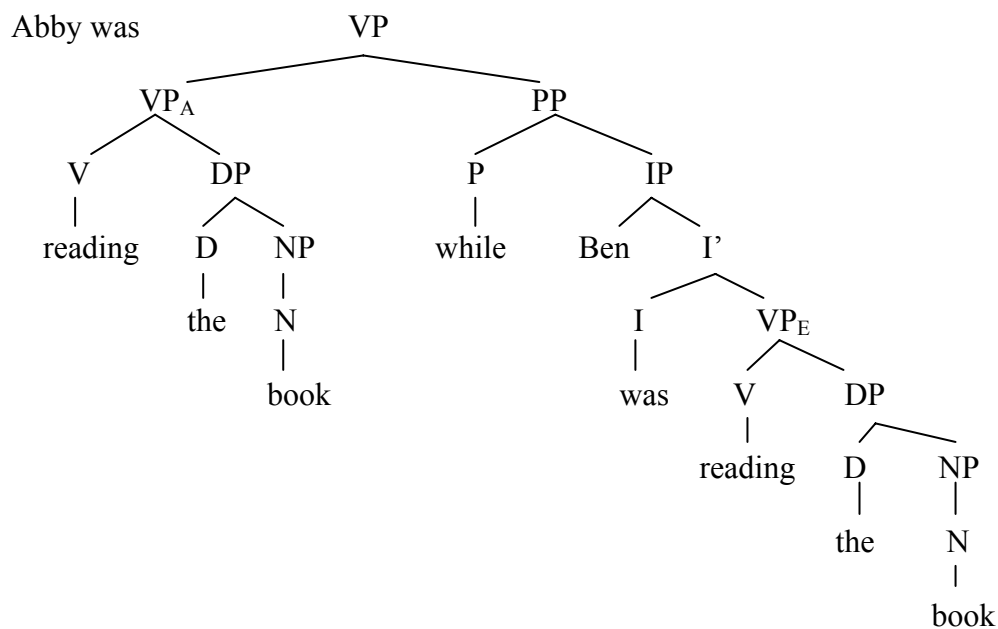

(34)

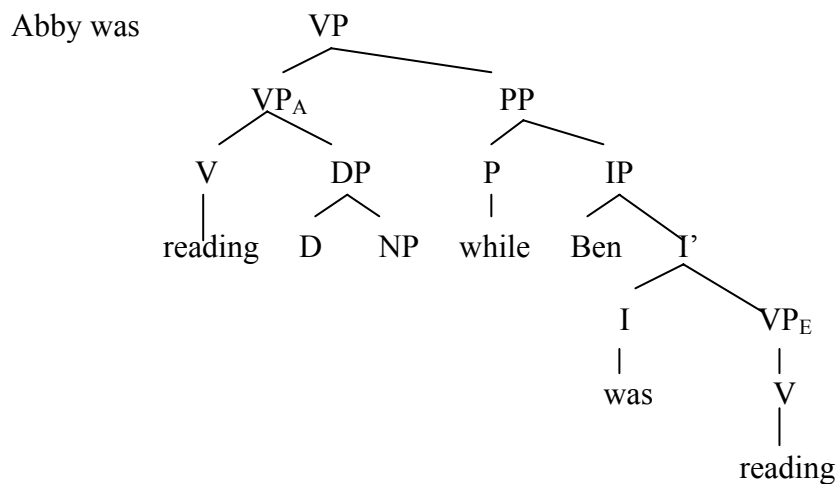

The hypothesis that the isomorphism condition seems to be structural rather than entirely semantic in character is also supported by the deaccenting example that was just discussed, since the possibility to establish semantic identity via inferability does not work here.¹⁰³ While it is possible to infer that Abby was reading from the sentence that Abby was reading a book, this inference alone is not sufficient to establish the appropriate condition for the licensing of deletion.

The isomorphism condition can also successfully account for slightly more complex structures such as the one given in (35) below (Merchant 2001: 19, his (22)), and the treatment of adjuncts, as shown in (36), where the only available interpretation is the one given in (36a). The reading in (36b), where the nominal adjunct is outside the ellipsis, is not possible (Merchant 2001: 19, his (23)).

(35) Abby [_{VP1} [_{VP2} left] after Ben did [_{VP3} leave]], and Carla did [_{VP4} ~~leave after Ben did~~] too.

(36) Abby [_{VP} met [_{DP} [_{DP} someone] from Kentucky]], and then Ben did.

a = <meet someone from Kentucky>

b ≠ <meet someone>

Since (36b) is not in an isomorphism relation with the antecedent VP [*meet someone from Kentucky*], the isomorphism condition correctly predicts the impossibility of deletion with the reading in (36b).

On the face of it, this isomorphism condition thus rules out the deaccenting structures, therefore accounting for the difference between deaccenting and elliptical structures.

However, Merchant (2001: 19ff.) points out that the isomorphism condition fails to work in Sluicing, more specifically, in Sluicing with implicit antecedents, as in (37) below (Merchant 2001: 19, his (24)).¹⁰⁴

¹⁰³ However, as we will see in what follows, Merchant's (2001) analysis achieves the same results semantically. Thanks to Howard Lasnik (p.c.) for valuable comments on this matter.

¹⁰⁴ Merchant (2001: 19ff.) adduces further contexts in Sluicing where the isomorphism condition also fails. I will not go into further detail here, but refer the reader to the discussion in Merchant (2001).

(37) Abby was reading, but I don't know what.

Recall the deaccenting example from (29) above, here repeated as (38).

(38) Abby was reading the book while Ben was reading.

In the discussion above, it was claimed that deletion is impossible in this configuration, since the two instances of the verb to read (transitive vs. intransitive) did not fulfil the isomorphism condition, and, furthermore, the inferences that could be established did not suffice to license deletion. By extension, this should also be true for the Sluicing example in (37). Despite the fact that IP_A is not equal to IP_E structurally, which is easily verified with the extension in (39), however, IP Ellipsis is licit.

(39) ... but I don't know what Abby was reading t.

Moreover, Merchant does not adopt the hypothesis that the isomorphism condition only holds for VP Ellipsis, not extending to Sluicing. This assumption is corroborated by the observation that in all relevant respects, Sluicing as IP Ellipsis behaves like VP Ellipsis (Merchant 2001: 23), and there is a similar resemblance between IP deaccenting and deaccented VPs.

Merchant (2001: 24) contends that the isomorphism condition also runs into problems with VP Ellipsis, in that it generally rules out cases which involve the so-called 'vehicle change' (cf. Fiengo and May 1994). One example of this phenomenon, where an equivalence between sometimes quite complex R-expressions and their corresponding pronouns must be established in ellipsis contexts, is given in (40) below (Merchant 2001: 24, his (38)).

(40) a. They arrested Alex₃, though he₃ thought they wouldn't.

b. They arrested [the guy who lives over the garage]₃, though he₃ thought they wouldn't.

Fiengo and May (1994) note that in these cases, a one-to-one correspondence between the antecedent VP and the deleted VP would yield the following extensions of the sentences in (40), given in (41) (Merchant 2001: 24, his (39)).

- (41) a. *He₃ thought they wouldn't arrest Alex₃.
b. *He₃ thought they wouldn't arrest [the guy who lives over the garage]₃.

(42) Principle C

An R-expression α with index i must not be c-commanded by any expression β with index i , β in an A-position.

Given Principle C of the Binding Theory, as paraphrased in (42) (Merchant 2001: 24, his (40)), the sentences in (41) are judged ungrammatical, in contrast to their non-overt counterparts in (40) above. To account for this curious state of affairs, Fiengo and May (1994) propose an operation of 'vehicle change'. This process is intended to allow us to treat the values of the feature [\pm pronominal] as 'equivalence classes' in the specific context of comparing two structures with one another. Thus, even though there is an R-expression in the second phrase, which is identical to the one in the antecedent, this R-expression is assigned the value [+pronominal]. As a consequence, Principle C is not violated, as desired. Given that the overt R-expression in the antecedent necessarily has to be [-pronominal], the distribution of R-expression with the [+pronominal] feature is restricted to ellipsis contexts. Obviously, though, there is a resulting feature mismatch now between the R-expression in the antecedent and the non-overt R-expression. By hypothesis, however, this (artificially created) mismatch, which Merchant calls "the heart of 'vehicle change'" (Merchant 2001: 25) does, in Fiengo and May's (1994) analysis, not affect the process of deletion.

While this analysis is feasible, Merchant (2001: 25) sharply criticises the status it is attributed in the debate of structural isomorphism. In his view, the fact that this process is limited to ellipsis, and does not extend to deaccenting, for instance, shows that the phenomenon of vehicle change is not yet adequate to capture the differences between the two processes, and its use in favour of a structural isomorphism account, is, from his perspective, clearly not warranted. As he puts it, "[t]o pursue a theory of ellipsis based on structural isomorphism while considering the cases of 'vehicle change' to have been sufficiently dealt with simply by naming them is to confuse the diagnosis with the cure." (Merchant 2001: 25).

This criticism, in its essence, seems to be a valid objection to the extent that it points out another problem for the claim that there is structural isomorphism. That is, in Merchant's

(2001: 24) interpretation of Fiengo and May's (1994) analysis, the crucial insight of their approach is that R-expressions that are situated in the antecedent trigger allow the licensing of pronouns in the deleted part of the structure, as expressed by the [+pronominal] feature discussed above. In the literal application of this hypothesis to the ellipsis cases in (40), Merchant (2001: 24) suggests that the structure in the ellipsis site be as in (43c) rather than the ones in (43a) and (43b) (Merchant 2001: 24, his (41)).

- (43) a *_{VP} arrest Alex₃
 b *_{VP} arrest [~~the guy who lives over the garage~~]₃
 c _{VP} arrest [him]₃

If the structure in (43c) is the desired one, however, again, the isomorphism condition is violated, according to Merchant, this time because there is a difference in vocabulary in the antecedent and the elided clause.

Thus, according to Merchant (2001: 25), the structural isomorphism constraint has to be revised (if not entirely rejected). In my view, however, there are two problems with this conclusion. Firstly, while the counterevidence against the structural isomorphism has to be acknowledged, the question remains as to the precise nature of the structural isomorphism condition that Merchant discusses. Recall that the first and foremost aim of the isomorphism condition was to ensure that there is a syntactically, structurally identical antecedent, for deletion to be licensed at all. Thus, if one wished to refute Merchant's (2001: 25) conclusion that structural isomorphism needs to be abandoned, one might argue that the structural isomorphism requirement is not what is at stake in the 'vehicle change' instances given above. In the sentences in (44) and (45) (repeated from (40) and (41) above), the structures are indeed the same in the elided part of the structure and the corresponding antecedent, hence, at face value, there is no need to assume an isomorphism violation.

- (44) a They arrested Alex₃, though he₃ thought they wouldn't.
 b. They arrested [~~the guy who lives over the garage~~]₃, though he₃ thought they wouldn't.

- (45) a. *He₃ thought they wouldn't arrest Alex₃.
 b. *He₃ thought they wouldn't arrest [~~the guy who lives over the garage~~]₃.

The problem arises once the indices on the relevant elements come into play, which then results in the Principle C violation, as illustrated above. Again, though, this violation of Principle C is not due to the isomorphism requirement, as far as I can see. To overcome the violation of the Binding Principle (though see the discussion in chapter 5 for discussion on where Binding applies), the feature setting is adjusted, based on the assumption that this change of feature value does not affect the ability to delete the relevant constituent. Indeed, as the grammaticality of the example sentences in (44) shows, this prediction seems to be borne out.

The ensuing feature mismatch, however, presumably violates the structural isomorphism requirement, in its strictest definition. The structural isomorphism requirement should then either (i) cause the deletion to be ungrammatical, contrary to fact, or (ii) take the featural mismatch in its stride. On the face of it, (ii) seems to be the better option. However, if one follows Merchant's (2001: 24f.) objections, literally replacing the R-expression in the antecedent with a pronoun in the deleted phrase would violate the structural isomorphism requirement, in its lexical or morphosyntactic dimension.¹⁰⁵ Under Merchant's (2001) account, however, the mismatch between the element in the antecedent and the corresponding material in the elided structure can be accommodated.

In sum, then, the structural isomorphism condition in its strongest definition fails to rule out instances of deletion, both in Sluicing and in VP Ellipsis, where structural isomorphism is not met. On the other hand, inferability alone does not suffice either (although Merchant 2001 claims it does), that is, a structural requirement is still at play, as we have seen in sentences such as in (29) above, here repeated as (46).

(46) Abby was reading the book while Ben was reading.

However, here, structural isomorphism can also be conceived to be a semantic requirement which concerns the overt realisation of arguments in the syntactic structure. In a sense, then, the meaning of the sentence, its semantic interpretation, is more directly involved in the licensing process of deletion than can be captured with the structural isomorphism condition. Therefore, from this perspective, Merchant's (2001) goal to abolish structural isomorphism in

¹⁰⁵ Note, however, that this conclusion is highly dependent on the general treatment of pronominal elements.

the derivation of ellipsis is an inevitable consequence. In particular, he proposes a Revised Focus Condition on the licensing of ellipsis, which I will discuss in the next part of this chapter.

7.4. The Revised Focus Condition

Merchant (2001: 25f.) suggests that since the structural isomorphism condition does not account for the data above and poses numerous problems, it should be abandoned entirely, and be replaced by a different principle.¹⁰⁶ This principle is defined such that it is based entirely on semantic and not structural conditions. While this procedure thus places Merchant's (2001) proposal in the long tradition of semantic accounts of ellipsis, Merchant (2001: 26) contends that his analysis differs from these approaches since it explicitly presumes that the elided part of the sentence has syntactic structure. Merchant (2001) develops his proposal on the basis of two previous semantic approaches to ellipsis, namely, Rooth's (1992b) licensing condition on ellipsis, and Schwarzschild's (1999) definition of Givenness. I will briefly discuss the relevant points of these two approaches in the following sections, before I turn to Merchant's analysis.

7.4.1. Rooth's Analysis (Rooth 1992 a, b)

Rooth (1992a) builds his analysis on the assumption suggested in Fiengo and May (1994) that there are two redundancy relations holding between an antecedent and the corresponding elided constituent. With VP Ellipsis, the antecedent VP_A and the elided VP_E are thus linked as illustrated in (47) (from Merchant 2001: 13, his (5)).

¹⁰⁶ As he puts it, "one that does not at the same time force us to revise our notions of featural constancy or do violence to the syntax of wh-movement." (Merchant 2001: 26).

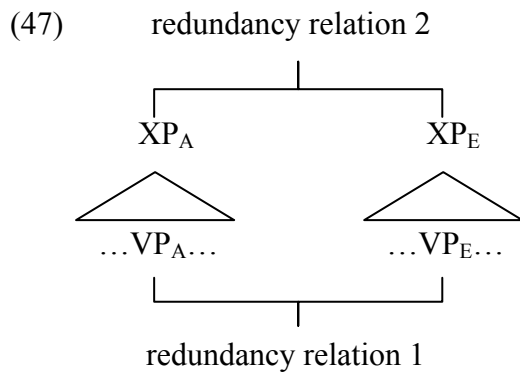

While Fiengo and May (1994) consider redundancy relation 1 to be syntactic, Rooth's (1992a) analysis, building on this assumption, is geared towards an account for redundancy relation 2, which is taken to be semantic in nature. More specifically, in Rooth's (1992a) approach, this redundancy relation 2 is expressed with the \sim operator. This operator is placed on a constituent at LF, α , iff there exist alternatives that have the same type as α .

For the configuration illustrated in (47), this means that $XP_A \sim XP_E$. In the paraphrase given in Merchant, Rooth's (1992a) requirement on ellipsis can be stated as in (48) (Merchant 2001: 13, his (6)).

(48) R-Focus condition on VP-ellipsis (Roothian version)

A VP α in XP_E can be deleted only if there is an XP_A , where $\|XP_A\|^o$ either is or implies an element of $\|XP_E\|^f$.

Applied to the example in (49) (Merchant 2001: 14, his (10)), a regular VP Ellipsis construction, this yields the following.

(49) a. Abby sang because [Ben]_F did.

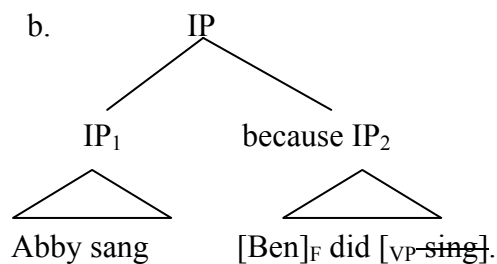

Here, the focus condition in Rooth's terms demands that $\|IP_1\|^0 \in \|IP_2\|^f$, i.e. that the ordinary value of IP_1 , the antecedent, is an element of the focus value of IP_2 , the elided clause, hence, a valid alternative of the set of alternatives denoted by the focus value of $\|IP_2\|$. Thus, $\lambda w.\text{sing}_w(a) \in \{\lambda w.\text{sing}_w(x: x \in D_e)\}$, where $a = \text{Abby}$ and D_e the domain of individuals in a given world w .¹⁰⁷

In the example (50) below (Merchant 2001: 15, his (11)), matters are slightly more complicated since a pronoun is present in the elided clause.

(50) a. Abby saw him after $[\text{Ben}]_F$ did.

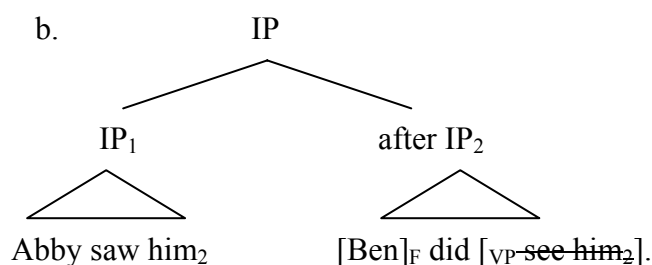

However, if the pronoun is taken to be translated with the variable x_2 in the LF structure above, the focus condition as suggested by Rooth (cf. (48)) will be satisfied iff the ordinary value of the antecedent *Abby saw him₂*, with the variable, is an element of the focus value of the sentence with the focused *Ben*, that is, $\|Abby\ \text{saw}\ x_2\|^0 \in \|[\text{Ben}]_F\ \text{saw}\ x_2\|^f$ needs to be true. More specifically, $\lambda w.\text{see}_w(a, g(x_2)) \in \{\lambda w.\text{see}_w(y, g(x_2)) \mid y \in D_e\}$, where g is the assignment function returning a value for x_2 in both instances, and $a = \text{Abby}$. The y , which is taken from the domain of individuals, is the variable that is substituted for the focused element.

This focus condition also holds for cases of deaccenting. The sentence in (51) illustrates a case of ‘implicational bridging’ in Rooth’s terminology (Merchant 2001: 15, his (12a)).

(51) Abby was reading the book while BEN *was reading*.

¹⁰⁷ Note that (21b) is supposed to be the LF representation of (21a), with the strikethrough material being deleted at PF (Merchant 2001: 14). While this is fairly straightforward, a crucial point here is that Merchant takes the feature triggering this PF deletion to be still present at LF (ibid.).

In these cases, a process of entailment or implicature is at work, that is, the antecedent implies material that is part of the focus value of the VP that is deaccented. In (51), *Abby was reading the book* clearly entails that *Abby was reading*, as shown in the first part of the formula in (52) below (Merchant 2001: 16, his (14)). The ordinary value of *Abby was reading*, that is, $\|Abby\text{ was reading}\|^o$, is an element of the focus value of *Ben was reading* in the deaccented VP, thus yielding the second part of (52).

(52) $\|Abby\text{ was reading the book}\|^o \rightarrow \|Abby\text{ was reading}\|^o$ and
 $\|Abby\text{ was reading}\|^o \in \|BEN_F\text{ was reading}\|^f$

In those instances where implicature fails, such as in the example given in (53) below (Merchant 2001: 16, his (16a)), the result is ungrammatical, which is also easily verified with the help of the focus condition in (48) above.

(53) **Abby was reading the book while BEN was coughing.*

However, as Merchant observes (Merchant 2001: 17), the focus definition as given in Rooth (1992a, cf. (48) above) does not provide the necessary distinction between deaccented and elided structures. Merchant (2001) thus proposes a further requirement, which is essentially based on Schwarzschild's (1999) account of Givenness, which I will discuss now.

7.4.2. Schwarzschild's Analysis (Schwarzschild 1999)

The results obtained with Rooth's (1992 a, b) analysis can also be captured with Schwarzschild's (1999) analysis. Schwarzschild (1999) bases his account on the concept of Givenness, which is defined as in (54) below (from Merchant 2001: 14, his (7)).

(54) Givenness (Schwarzschild 1999)

1. If a constituent α is not F-marked, α must be given.
2. An expression E counts as given iff E has a salient antecedent A and, modulo \exists -type shifting, A entails the F-closure of E.

The existential type shifting operation in (54) is intended to bind unfilled arguments, and to raise expressions to type t . The F-closure of an expression E , in turn, is defined as in (55) (Merchant 2001: 14, his (8)). The entailment in this definition is taken to be “some kind of contextual entailment, where certain background information is assumed” (Schwarzschild 1999: 151, cited in Merchant 2001: 16, fn. 5).

(55) F-closure

The F-closure of α , written $F\text{-clo}(\alpha)$, is the result of replacing F-marked parts of α with \exists -bound variables of the appropriate type (modulo \exists -type shifting).

The resulting focus condition on VP Ellipsis is thus as in (56) (Merchant 2001: 14, his (9)).

(56) S-Focus condition on VP-ellipsis (Schwarzschildian version)

A VP α can be deleted only if α is or is contained in a constituent that is given.

Merchant (2001: 14) shows that Schwarzschild’s (1999) focus condition in (56) accounts equally well for the data repeated as (57) and (58) below.

(57) a. Abby sang because $[\text{Ben}]_F$ did.

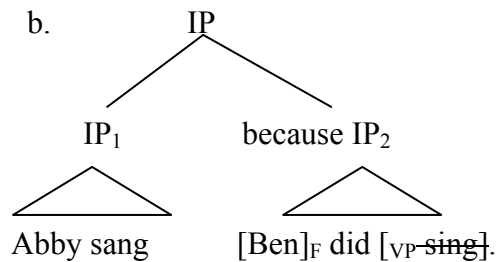

In (57), the antecedent *Abby sang* entails the VP that is deleted: $\exists x.\text{sing}(x)$ (with \exists -type shifting). Thus, the deleted VP counts as given.¹⁰⁸

¹⁰⁸ Comparing the IPs yields the same result: the antecedent *Abby sang* entails $\exists x.\text{sing}(x)$, which is obtained by replacing the F-marked element $[\text{Ben}]_F$ with an existentially bound variable.

(58) a. Abby saw him after [Ben]_F did.

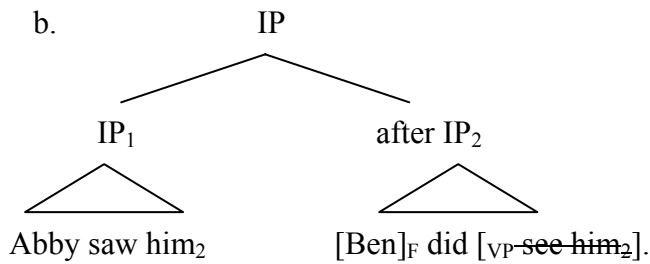

In (58), which involves a pronoun, the antecedent IP needs to entail $\exists x.\text{see}(x, g(x_2))$ such that x is Abby.¹⁰⁹

In the deaccenting case in (59), applying Schwarzschild's focus condition in (56) is straightforward, since *Abby was reading the book* clearly entails that there is an x such that x is reading ($\exists x.x$ was reading), thus licensing the deaccenting.

(59) Abby was reading the book while BEN *was reading*.

Again, as in the case of Rooth's (1992 a, b) account, Schwarzschild's (1999) condition does not capture the full range of restrictions on VP Ellipsis, where it seems that strict identity of meaning is necessary, rather than simply implications (Merchant 2001: 16). Based on this assumption, Merchant proposes an extension of Schwarzschild's account, as we will see in what follows.

7.4.3. E-Givenness (Merchant 2001)

As mentioned above, Merchant's goal is to develop a requirement that captures the restrictions that hold for ellipsis, as opposed to deaccenting. Given the controversial status of the structural isomorphism condition, Merchant proposes that the requirement in question should be solely semantic in nature. To this end, he proposes a revised Focus condition, which is intended to account both for VP Ellipsis and IP Ellipsis (Sluicing).¹¹⁰

¹⁰⁹ See the discussion in previous sections for details on the variable assignment $g(x_2)$.

¹¹⁰ Merchant (2001: 26) notes that his aim is to account mainly for IP Ellipsis. Given the overall topic of this dissertation, however, I will place the main emphasis in this section on VP Ellipsis rather than IP Ellipsis.

As we have seen above, Schwarzschild (1999) gives a bipartite definition of Givenness, which is adapted and extended in Merchant's (2001) analysis. Recall that Schwarzschild's (1999) definition of Givenness, here repeated as (60) (cf. (56) above).

(60) Givenness (Schwarzschild 1999)

1. If a constituent α is not F-marked, α must be Given.
2. An expression E counts as Given iff E has a salient antecedent A and, modulo \exists -type shifting, A entails the F-closure of E.

First of all, he states that not F-marked material has to be treated as given. In reverse, F-marked material is (quite trivially) treated as focused. However, the concept of givenness is a contextually related parameter.¹¹¹

As it is quite straightforward that given material cannot always be deleted, the second part of Schwarzschild's definition of Givenness is concerned with the identification of a proper antecedent, simply stated as a precondition ("[E] has a salient antecedent A", cf. (56) above). More specifically, this antecedent has to entail the interpretation that the deleted constituent has, e.g. *Abby sang* entails that there is an x such that x sings, $\exists x.\text{sing}(x)$, which is why the second VP in *Abby sang because Ben did*, [_{VP} sing], can be deleted.

In the second part of Schwarzschild's (1999) definition of Givenness, the antecedent A entails the F-closure of the elided phrase E. As Merchant (2001: 14) notes, Schwarzschild's (1999) concept of givenness thus incorporates Rooth's (1992) insight of the existence of alternatives, more specifically, that the antecedent XP be or at least imply an element of the focus value (the alternatives) of the deleted XP (i.e., (48)).

This givenness requirement is then refined by Merchant (2001), in that he adds a second condition to Schwarzschild's Givenness requirement in (60) to the effect that not only does A entail the F-closure of E, but E also has to entail the F-closure of A. This additional requirement is then part of Merchant's definition of E-Givenness in (61) (Merchant 2001: 26, his (42)).

¹¹¹ Roger Schwarzschild (p.c.) notes that the actual limitation of the domain in which the elements in the phrase counts as given should be irrelevant in the computation of Pseudogapping. I will come back to this point.

(61) E-Givenness

An expression E counts as e-Given iff E has a salient antecedent A and, modulo \exists -type shifting,

- (i) A entails F-clo(E), and
- (ii) E entails F-clo(A).

By this means, the entailment relation has become a semantic relation that is closer to the concept of semantic identity, and is thus a particular type of entailment, which Merchant (2001: 26) takes to be valid in deleted structures (and not elsewhere).

Merchant (2001, 26f.) points out that without this extra condition, what remains of the E-givenness requirement is the focus conditions, which “will certainly apply to structures that contain ellipsis as well. For purposes of exposition, however, I will collapse the two requirements on elliptical structures (the more general focus conditions plus clause (ii) of (42) [(61)] into one definition – this will allow us to refer to a structure as simply satisfying the e-Givenness requirement, though the careful reader may want to keep this conflation in mind.” (Merchant 2001: 27).

The E-Givenness condition as proposed by Merchant accounts for the difference between deaccented and elided structures, as we will see in what follows. Consider again the difference between the examples in (62) and (63) below (Merchant 2001: 15, 17, his (12a) and (18a)).

(62) Abby was reading the book while BEN *was reading*. (Deaccenting)

(63) Abby was reading the book while BEN was. (Ellipsis)

In the example in (62) (Merchant 2001: 27, his (45)), which is discussed in detail in Merchant (2001), the point is made clear: It needs to be made sure that (64) corresponds to (65a) and not to (65b) (Merchant 2001: 27, his (46)).

(64) Abby called Chuck an idiot after BEN did.

(65) a. = after BEN did ~~call Chuck and idiot~~.

b. ≠ after BEN did ~~insult Chuck~~.

First of all, the deleted VP in (64) has to be E-Given. The antecedent, the VP [*VP call Chuck an idiot*], has an open variable which replaces the subject. With \exists -type shifting, the structure is as in (66) (Merchant 2001: 27, his (47)), with the apostrophe indicating the \exists -type shifting result.

(66) $VP_A' = \exists x.x$ called Chuck an idiot.

According to the definition in (61i), VP_A' has to entail VP_E , with replacing F-marked material in the deleted VP via existentially bound variables. The result of this operation is given in (67) (Merchant 2001: 27, his (48)).

(67) $F\text{-clo}(VP_E) = \exists x.x$ called Chuck an idiot

Here, the trace of the subject BEN (inside the VP) is also taken to be F-marked, to be able to be replaced with the variable. Merchant (2001: 27) claims that there is nothing crucial hinging on the assumption that the trace in question be F-marked. Since VP_A' thus entails $F\text{-clo}(VP_E)$, the second condition, i.e. the reverse, has to be checked, as illustrated in (68) (Merchant 2001: 28, his (49)).

(68) $F\text{-clo}(VP_A) = \exists x.x$ called Chuck an idiot

Given that (67) and (78) are identical, the second condition, i.e. VP_E' entailing $F\text{-clo}(VP_A)$, is met.

In the corresponding deaccenting example in (65b), the first condition, i.e. that VP_A' entails $F\text{-clo}(VP_E)'$, is fulfilled, since calling somebody an idiot is clearly a case of insulting somebody. However, the second condition, the identity-establishing condition for deletion, (33ii), is not fulfilled, since VP_E' does not entail $F\text{-clo}(VP_A')$, as illustrated in (69) (repeated from (65b) above).

(69) ≠ after BEN did ~~insult~~ ~~Chuck~~.

With respect to the cases of ‘vehicle change’ discussed in the section on structural isomorphism, Merchant (2001: 28) contends that the elimination of the isomorphism condition allows, not surprisingly, a different treatment of the vehicle change cases. Crucially, it allows the assumption that there simply is a regular pronoun inside the deleted VP, as illustrated in (70) below (Merchant 2001: 28, his (51)).

(70) a They arrested Alex₃, though he₃ thought they wouldn’t ~~arrest~~ ~~him~~₃.

b They arrested [the guy who lives over the garage]₃, though he₃ thought they wouldn’t ~~arrest~~ ~~him~~₃.

Merchant (2001: 28) shows that the deleted VP in (70a) obeys the conditions in (61), iff *him* corresponds to *Alex*. \exists -type shifting of VP_A , as in (71a) below (Merchant 2001: 28, his (52)), yields the desired result of entailing the F-closure of the deleted VP (71b)—if the assignment function for $him(x_3)$ chooses the same element that is chosen by the assignment function for *Alex*. Moreover, the condition corresponding to (61ii), that VP_E' entails the F-closure of VP_A' , is met.

(71) a $VP_A' = \exists x.x$ arrested Alex

b. $F\text{-clo}(VP_E) = \exists x.x$ arrested him

In this case, Schwarzschild (1999: 154) reaches the same result: the pronoun will be given, if it has an antecedent with the same index. In his terms, $\|John_i\|^g = \|he_i\|^g$.

7.4.4. E-Givenness and Contrast

There are cases of ellipsis which, unlike VP Ellipsis, require the presence of F-marked material. In this section, I will discuss one instance of Sluicing, and Pseudogapping.

In the so-called ‘contrast’- sluice (Merchant 2001: 36) in (72) (ibid., his (81a)), there is contrastive material in the second IP.

(72) She has five CATS, but I don't know how many DOGS.

The structure in (73) (ibid., his (82)) illustrates what is deleted in (72).

(73) She has [five CATS]_F, but I don't know how many DOGS [~~IP she has t~~].

The condition in (61ii) above is satisfied, as shown in (74) (Merchant 2001: 36, his (83)).

(74) a $IP_E' = \exists x. she \text{ has } x$

b $F\text{-clo}(IP_A) = \exists x. she \text{ has } x$

If however, the material contrasting with *DOGS* is considered in the computation of IP_A , the deletion should be ungrammatical, since *she has five cats* is not a licit entailment of IP_E' in (74a) above. Thus, this case clearly illustrates the necessity for the abstraction process assumed in the conditions in (61), which then yields the correct result in (74).

However, while the above cases can be accounted for, a further restriction has to be borne in mind (cf. Merchant (2001: 37, fn. 17)). In Sluicing, it is necessary that the F-marking contrast with the *wh*-phrase that has been moved out of the IP, to rule out examples such as (75) (ibid., his (i)).

(75) A: Who did Abby see?

B: *Abby [_{VP,A} saw BEN_F], and Carla did [~~VP,E see someone~~] too.

The F-marking on BEN yields $F\text{-clo}(VP_A) = \exists x \exists y [x \text{ saw } y]$ and $VP_E' = \exists x \exists y [x \text{ saw } y]$. On these grounds, deletion would be licit. However, F-marking must be anaphoric, such that, if I interpret Merchant's assumptions correctly, $VP_E' = \exists x. x \text{ saw Ben}$. Merchant (2001: 37, fn. 17) notes that Givenness has to be sensitive to anaphoricity relations.

With respect to the second case, where contrast is involved, Pseudogapping, Merchant (2001: 29, fn. 11) proposes the following. Recall first the focus condition on ellipsis, given again in (76) below (Merchant 2001: 38, his (84)).

(76) Focus Condition on ellipsis

A constituent α can be deleted only if α is e-Given.

According to Merchant, this focus condition (76) makes sure that the material in the antecedent that corresponds to the remnant XP in Pseudogapping in (68), for instance, is focused. Consider the examples in (77) and (78) (Merchant 2001: 29, fn. 11, his (i) and (ii)).

(77) I saw [Abby]_F, but [Bart]_F, I didn't.

(78) I want to see [the Simpsons]_F more than I do [the X-files]_F.

In the example with the fronted XP in (77), for example, $VP_E' = \exists x \exists y [x \text{ saw } y]$. The F-closure of the antecedent would be $F\text{-clo}(VP_A) = \exists x \exists y [x \text{ saw } y]$. However, in this case, the \exists -type shifted VP_E' does not entail the \exists -type shifted VP_A' , VP_A' being $\exists x [x \text{ saw } Abby]$.

Suppose now that *Abby* in VP_A were not F-marked. Then, the F-closure of VP_A would *not* be entailed by VP_E' , and, as a consequence, it would not be possible to delete VP_E . On the basis of this observation, Merchant (2001) thus contends that the material in the antecedent has to be focused.¹¹²

7.5. Problems for the Revised Focus Condition

As we have seen in the discussion above, Merchant's (2001) e-Givenness condition relies on a two-way entailment relation to establish semantic identity in ellipsis (cf. (33ii)). However, being that his condition is essentially semantic, there are some cases in which structural assumptions do seem to play a role, which are less straightforwardly accommodated with an approach based on Givenness. I will start the discussion with two instances where the analysis in terms of Givenness and entailment works fine, before I turn to a potentially problematic case.

¹¹² Merchant (2001: 29, fn. 11) also points out that "[i]t seems to be necessary as well that some overt material in the clause containing the deleted VP be present to indicate the possibility of F-closure in the antecedent; see Fox (2000) for related discussion."

7.5.1. E-Givenness and Argument Alternations

Consider the example of VP deaccenting in (79) (Merchant 2001: 15, his (12a)), with the corresponding structure in (80) below (Merchant 2001: 18, his (21)).

(79) Abby was reading a book while Ben *was reading*.

Recall that in this instance, deletion is ruled out since VP_A , *Abby was reading the book* does entail that $\exists x.x$ was reading, that is, the essential meaning of VP_E , but that *Ben was reading*, in turn, does not entail that $\exists x.x$ was reading a book. As we have seen, there is no semantic identity between VP_A and VP_E , which would have been verified with Merchant's (61ii) condition, and deletion is thus ruled out.

(80)

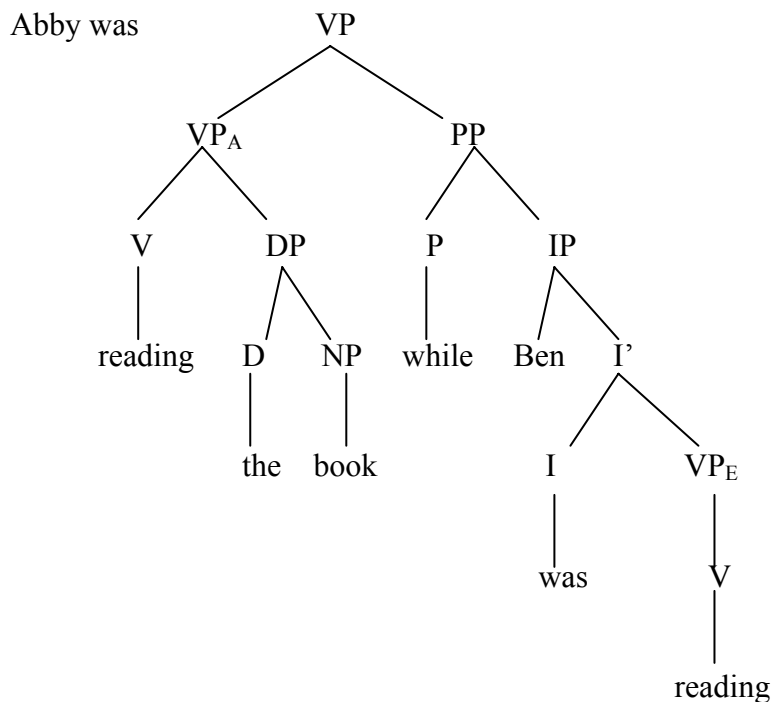

While this result could either be fully accounted for with a structural isomorphism constraint, or with the Focus Condition in Merchant's (2001) analysis, what seems to be lying at the heart of the matter here is the argument structural configuration in the antecedent and the

deaccented clause. Since Merchant rejects the structural isomorphism requirement, let us see how other types of argument structural variations can be accounted for.

Consider Sluicing in (81).¹¹³

(81) a. *She served the soup, but I don't know who(m).

(Cf. She served the soup, but I don't know to whom.)

b. She served the students, but I don't know what.

To account for these cases, Merchant (2001: 33, his (70)) assumes two different argument structures for the verb *to serve*, given in (82) below.

(82) a *serve*₁: server <meal (diner)>

DP PP_{to}

b *serve*₂: server <diner (meal)>

DP DP

Based on these alternatives in argument structure, Merchant (2001: 33) contends that the observation that Sluicing is not licensed in (81a) above must be due to a difference in inferability, which incorporates the information from unexpressed arguments. Thus, for the sentence in (83) (Merchant 2001: 34, his (72)), a variant of (81b) above, the relevant implicatures are given in (84) (ibid., his (73)).

(83) *She served₁ the meal, but I don't know WHO *she served*₁ it to.

(cf. She served₁ the meal, but I don't know who *she served*₁ it TO.)

(84) a IP_A = she served the meal

b F-clo(IP_E) = ∃x[*she served* the meal to x]

Merchant concludes (Merchant 2001: 34) that in (83), deaccenting is prohibited, because the preposition is not Given. In the IP Ellipsis example in (85), repeated from (81a) above, there need not be a preposition involved, if the verb *to serve* is of the first type, *serve*₁ in (82a).

¹¹³ Merchant (2001: 33, his (69)), based on Chung et al. (1995).

(85) *She served₁ the meal, but I don't know WHO_i ~~she served₂ t_i the meal.~~

(cf. She served₂ someone the meal, but I don't know who_i ~~she served₂ t_i the meal.~~)

In (81a), then, there is a clash between the two verb types, since only the second, *serve*₂, requires the presence of a recipient. Once the recipient is present in the antecedent, as the *someone* in the grammatical sentence in brackets, both verbs are of type *serve*₂, allowing for Sluicing. In terms of entailment, this relation can be captured as in (86) (Merchant 2001: 34, his (75)).

(86) a IP_A = she served the meal

b F-clo(IP_E) = $\exists x$ [she served x the meal]

The problematic instances for the theory of licensing ellipsis based on Givenness are contexts which involve a different kind of argument alternation, namely, the passive-active alternation (cf. also Merchant 2007 for related discussion).

Consider first the Sluicing case in (87) (Merchant 2001: 35, his (76), attributed to S. Chung).

(87) *Someone shot Ben, but I don't know by who(m) [~~IP Ben was shot t~~].

Here, the subject of the antecedent in active voice generates entailments that the passive counterpart of the elided sentence does not, which yields the desired result of excluding Sluicing in (87) above, based on Givenness.

In Pseudogapping, in the example given in (88) (cf. Merchant 2001: 35), the situation is similar to (87): having a Pseudogapping derivation with an active antecedent and passive voice in the elided counterpart results in ungrammaticality.

(88) *Abby shot Ben {before/and} Chuck was by Dana.

This state of affairs could thus equally well be captured by means of differing lexical entailments, according to Merchant's (61ii).

However, as Merchant (2001: 35) indicates already, for VP Ellipsis, the situation is more complex in passive-active alternations. In a recent paper (Merchant, forthcoming), Merchant maintains that voice alternations are actually possible in VP Ellipsis, as illustrated in (89) and (90).

(89) The system can be used by anyone who wants to. <use it>

(90) Actually, I have implemented it [= a computer system] with a manager, but it doesn't have to be. <implemented with a manager>

As can be seen from these examples, the voice alternations can go both ways. If we consider the above argument that Givenness, based on lexical entailment, rules out a contrast between passive and active voice in antecedent vs. elided clause, the above data are quite puzzling. The question thus arises what is responsible for the grammaticality of these sentences, since the final status of acceptability in these examples clearly should not be a result of lexical entailment. Moreover, in other contexts, we do find a high sensitivity to argument alternations in ellipsis, as shown in (91), where the elided clause can only be reconstructed as *Ben was reading the book*, and not as **Ben was reading*.

(91) Abby was reading the book while BEN was. (*Ellipsis*)

A second problem related to the concept of Givenness will be addressed in the following section.

7.5.2. E-Givenness and F-Marking

Cases where the deaccented and elliptical structures involved contrast between the antecedent and the deaccented or elided part of the clause are, according to Merchant, (more or less) compatible with his system, modulo an incorporation of anaphoricity into the notion of Givenness. A more severe problem for the notion of Givenness, however, arises in sentences in which F-marking seems to be absent from the antecedent. Again, according to Merchant, these cases, too, can be accommodated, though we will see below that they are less straightforward than they appear to be.

Consider the example in (92) below (Merchant 2001: 35, his (77)), where no F-marking is indicated on the antecedent. Nonetheless, the resulting interpretation should be as shown in the strike-out material.

(92) She called Ben an idiot, but I don't know who else [~~if she called t an idiot~~].

Apparently, the condition in (61ii) is not satisfied. If there is no F-marked material in the antecedent, $IP_E' = \exists x. \text{she called } x \text{ an idiot}$. However, the desired F-closure would be $F\text{-clo}(IP_A) = \text{she called Ben an idiot}$. Clearly, this is not a valid entailment of IP_E' . Why then is (92) grammatical, which is unexpected under the approach proposed above?

To account for this curious situation, Merchant (2001: 35) resorts to establishing F-marking in the antecedent, illustrating his point with the example given in (93), with the relevant Sluicing examples in (94) (ibid., his (78) and (79)).

(93) a. $ABBY_F$ called Ben an idiot, but I don't know who else.
 b. Abby called BEN_F an idiot, but I don't know who else.

(94) a. ... but I don't know who else called Ben an idiot.
 b. ... but I don't know who else Abby called an idiot.

The comparison between (93a) and (94a), and (93b) and (94b) show, according to Merchant (2001: 34), that the Focus condition is satisfied in these cases, since the entailment relations hold. In (95) (Merchant 2001: 35, his (80)), the situation in (93a) is given as an example, that is, the case where *Ben* is not F-marked.

(95) a. $IP_E' = \exists x. x \text{ called Ben an idiot}$
 b. $F\text{-clo}(IP_A) = \exists x. x \text{ called Ben an idiot}$

The same holds for the case in (94b), where the existential closure yields $\exists x. \text{Abby called } x \text{ an idiot}$, for the sentence where $[Ben]_F$ is F-marked. Clearly, then, there is a crucial requirement that a contrast be established with some element in the antecedent (in the case of (92), a contrast between *Ben* and *who else*).

The non-trivial part of this procedure stems from the fact that non-F-marked elements are given, and that, by default, F-marked elements are not given. While, to the best of my knowledge, there have been proposals in the literature to weaken the second of these assumptions, the problem remains that there are two instances in which the element in the antecedent may (not necessarily must) be F-marked: if it is not given, or if it is in contrast to an element in the deaccented or elided part of the clause. Consider now a sentence such as the one in (96) below.

(96) ‘Gerard *Logan!*’ The tall dog-walker, astounded, bending to look at me, knew me by sight, as I did him. (Dick Francis, *Shattered*, 68)

In this example, there is no a priori reason to assume that *me* in the antecedent is not given. The only possible option of attributing this element with the necessary F-marking is by placing it in a contrast with *him* in the second part, the Pseudogapping part of the sentence. While *him* necessarily bears contrastive focus, it is not entirely clear whether the element in the antecedent actually has to bear contrastive focus too. For the accounts given in Rooth (1992a, b), and the definition of Givenness in Schwarzschild (1999), the question whether the antecedent is focused or not is not as paramount as for the account proposed in Merchant (2001), since his (61ii) crucially depends on there being an F-closure of the antecedent, i.e. F-marking in the antecedent.

Moreover, given that the anaphoricity holding between the two remnants is not explicitly built into his E-Givenness requirement, in Merchant’s (2001) analysis, there is no straightforward way to capture Givenness (or rather, the lack thereof) in terms of a contrast between two elements in the clause. Hence, if there is a situation in which an element in the antecedent is clearly given in the context, the mechanism as proposed in Merchant’s (61ii) fails if there is no explicit F-marking.

7.5.3. Reconsidering E-Givenness

While the second condition introduced into the definition of Givenness, turning it into E-Givenness, repeated in (97) below, accounts for the difference between deaccenting and

ellipsis, the question arises, in view of the problems pointed out above, whether Givenness is actually the most appropriate way to express this requirement on ellipsis.

(97) E-Givenness

An expression E counts as e-Given iff E has a salient antecedent A and, modulo \exists -type shifting,

- (i) A entails F-clo(E), and
- (ii) E entails F-clo(A).

On the basis of the discussion in the last two sections above, it seems rather that the decisive notion that should be involved in the satisfaction of the condition in (69ii) should be the presence or absence of contrast between antecedent and deaccented or elided clause rather than the concept of Givenness. Recall from above, too, that there are, informally speaking, two contexts in which a constituent in the antecedent needs to be F-marked, either, following Merchant (2001), and, to some extent, Schwarzschild (1999) if it is not Given, or, more generally, if it is contrasted with some other element in the sentence, that is, with material in the second part of the clause. If now, as has been suggested in Merchant (2001), the focus conditions put forward by Rooth (1992a, b) and Schwarzschild (1999) can be considered to be largely equivalent in their basic insights, the question is why it should not be possible to divorce Merchant's (2001) E-Givenness condition from the actual requirement of Givenness, and rather define it such that the contrast between material in the antecedent and in the second conjunct is emphasised. As the notion of contrast can be incorporated more easily in Rooth's (1992a, b) framework, and his focus condition, I thus propose that the notion of Givenness might be abandoned altogether, and the E-Givenness condition defined in Rooth's (1992a, b) terms. This new definition, obviously, strictly relies on the argumentation in Merchant (2001), as discussed at the beginning of this chapter, that the two proposals, the one by Rooth (1992a, b) and the one by Schwarzschild (1999) have an equal amount of explanatory power with respect to the data discussed throughout this chapter. In the following section, I will thus illustrate how the E-Givenness requirement could be recast in Rooth's (1992a, b) terminology, before I move on to the syntactic implementation of this E-Givenness requirement, however phrased, by means of the E-feature in the next chapter.

7.5.4. Rephrasing the E-Givenness Condition

Recall that Merchant (2001) noted upon the introduction of his E-Givenness condition (in (98)) that the first part of this definition corresponded exactly to the focus conditions given in Rooth's (1992a, b) or Schwarzschild's (1999) account.

(98) E-Givenness

An expression E counts as e-Given iff E has a salient antecedent A and, modulo \exists -type shifting,

- (i) A entails F-clo(E), and
- (ii) E entails F-clo(A).

The second condition (ii) is thus the only part Merchant (2001) changed with respect to this general focus condition.

The focus condition in Rooth's (1992a) terms is given in (99) (Merchant 2001: 13, his (6)).

(99) R-Focus condition on VP-ellipsis (Roothian version)

A VP α in XP_E can be deleted only if there is an XP_A , where $\|XP_A\|^o$ either is or implies an element of $\|XP_E\|^f$.

In analogy to Merchant's (2001) extension of his focus condition on ellipsis in (100) (Merchant 2001: 38, his (84)) to cover all instances of ellipsis, it should be possible to extend Rooth's Focus condition in (99) to also cover all possible cases of deletion. Thus, the relevant rephrasing of the formula in (100) is given in (101) below.

(100) Focus Condition on ellipsis (Merchant 2001)

A constituent α can be deleted only if α is e-Given.

(101) Focus Condition (*First Part*)

A constituent α in XP_E can be deleted only if there is an XP_A , where $\|XP_A\|^o$ either is or implies an element of $\|XP_E\|^f$.

What about the second clause, that is, (98ii) above? Given that it is the exact counterpart of the first part of the definition, (98i), it should be possible to rephrase this argument, too, in Rooth's (1992a, b) terminology, thus yielding the final version of the focus condition on ellipsis in (102) below.

(102) Focus Condition on Ellipsis (*Final Version*)

A constituent α in XP_E can be deleted only if there is an XP_A , where

- (i) $\|XP_A\|^0$ either is or implies an element of $\|XP_E\|^f$, and
- (ii) $\|XP_E\|^0$ either is or implies an element of $\|XP_A\|^f$.

In sum, the definition given in (102) avoids the tricky concept of Givenness, as we will see in the relationship between the \sim operator and the E-feature, makes the interaction between deletion and the contrast between the two elements in the antecedent and the deaccented or elided clause more explicit.

7.6. Conclusion

On the basis of this requirement for the licensing of focus and deletion outlined above I will thus proceed to show how the deletion process can be implemented in the syntax, by means of the E-feature, which then, as we will see, interacts with the focused elements in its domain.

8. The Deletion Process

In this chapter, I will propose a general analysis of the deletion process, and show how it can be applied to Pseudogapping, and subsequently extended to other instances of ellipsis. The main feature of the deletion operation I suggest is Merchant's (2001) E-feature, which is then, in a first step, examined with respect to its interaction with the EPP-feature from Lasnik's (1995a, 1999a, a.o.) analysis. As we have seen in previous chapters, there is clear evidence that A-bar-movement, e.g. in terms of focus movement, is involved in Pseudogapping. Consequently, the movement operation in Pseudogapping could be considered to be due to a [+contrastive] feature, marking the necessary contrast in ellipsis (cf. the proposals in previous work of mine), or else be due to the more traditional [+focus] feature. Crucially, I contend that there is an interaction between the two features, based on the original definition of Merchant's (2001) E-feature, which, as we will see, not only specified the relevant parts of the structure for phonological deletion, but also established semantic identity. While I will keep these two key insights, I will proceed to add another dimension in assuming that the relevant movement in Pseudogapping (and other ellipsis cases) is not only due to the mere presence of a [+contrastive] or [+focus] feature on the remnant – the feature in itself would not necessarily trigger movement – but to the presence of this particular feature within the deletion domain specified by the E-feature.

The chapter is structured as follows. In the first part, I will present Merchant's (2001) analysis of the E-feature, and modify it such that the feature movement process he assumes for this E-feature is no longer required, thereby simplifying his analysis. I will also show that there seems to be a complementarity between verb raising and the E-feature on V, thus taking up suggestions from Lasnik's (1999a, 2005, a.o.) analysis.

8.1. The Definition of the E-Feature

In this section, I discuss Merchant's (2001) E-feature, beginning with an overview of the lexical and structural licensing condition of ellipsis, which is captured with the E-feature.

8.1.1. Features licensing Ellipsis

One of the most comprehensive accounts of ellipsis in the literature is Lobeck's (1995) analysis. Following the hypothesis that ellipsis involves chiefly two processes, namely the licensing process and the identification process (the latter ensuring interpretability of the deleted material), she contends that the concept of government is crucial for the derivation of ellipsis.¹¹⁴ Given Lobeck's (1995) claim that there is an empty category in ellipsis, and recent developments in the Minimalist Program that were apt to dispense with the notion of government altogether, Lobeck (1999) rephrases her account such that the null category now moves into the specifier of the head that licenses deletion. Applied to VP Ellipsis, the licensing head in question would be T (given the obligatoriness of the auxiliary), thus, the null category, a null VP, moves into [Spec,TP]. In her terms, the empty VP needs to check a strong agreement feature, via Specifier-Head agreement. An obvious side effect of this analysis is that the subject must be elsewhere, not being able to be in [Spec,TP], in fact, Lobeck (1999) assumes that it targets the Agr_SP specifier instead.¹¹⁵

On the basis of Lobeck's (1995, 1999) analysis, Merchant (2001: 60) proposes that the fundamental relation between the licensing category and the ellipsis site should be maintained, in a local head-head relation rather than a specifier-head relation. Alternatively,

¹¹⁴ In particular, the concept of head government, which is in some sense related to the ECP, as pointed out by Merchant (2001: 60).

¹¹⁵ Merchant (2001: 60) notes that this analysis cannot be extended to Sluicing, since [Spec,CP] would always be blocked as a landing site by the moved *wh*-phrase. However, if one wished to pursue her line of reasoning, and taking into account the proposal made in Rizzi (1997) that *wh*-phrases target the head of a focus phrase FocP in the CP domain, a Lobeck-style analysis would be feasible. Likewise, in VP Ellipsis, one could potentially assume movement of the subject to a higher subject position (however this position would be characterised), and thus explain the focus on the subject in VP Ellipsis that some researchers claim to be present on the subject (cf., for instance, the relevant examples in Merchant 2001). Given that my overall analysis of ellipsis is concerned more with object positions than with subject positions, and that the focus on the subject in VP Ellipsis is not invariably present, e.g. not in the cases where the subject in the second conjunct is the same subject as in the antecedent (a situation replicated in Pseudogapping), I will not pursue the matter here.

this relation could also be expressed in a relation between features. The relevant feature at work, specifying the deletion site, is a feature that he calls E-feature.

8.1.2. The Semantics of the E-Feature

In Merchant's (2001) analysis, the E-feature is defined such that it has a particular semantics, and, in addition, a phonological effect, triggering deletion. According to Merchant (2001: 61), the E-feature imposes on the elided constituent the Focus Condition, based on Givenness, that is, the E-Givenness condition in (1) (Merchant 2001: 26, his (42)).

As we have seen in the discussion in the previous chapter, however, this condition can also be captured with a requirement based on Rooth's (1992a, b) account of focus, as illustrated in (2).

(1) E-Givenness:

An expression E counts as e-GIVEN iff E has a salient antecedent A and, modulo \exists -type shifting,

- (i) A entails F-clo(E), and
- (ii) E entails F-clo(A).

(2) Focus Condition on Ellipsis (*Final Version*)

A constituent α in XP_E can be deleted only if there is an XP_A , where

- (i) $\|XP_A\|^0$ either is or implies an element of $\|XP_E\|^f$, and
- (ii) $\|XP_E\|^0$ either is or implies an element of $\|XP_A\|^f$.

In Merchant's terms, if E combines with IP, a failure to delete, due to the Focus Condition, should be treated as a presupposition failure (Merchant 2001: 61), which, in turn, permits us to express the meaning of E with a partial identity function, as given in (3) in Merchant's formulation (*ibid.*, his (69)).¹¹⁶

¹¹⁶ Merchant here follows the implementation for Φ -features in Heim and Kratzer (1998: 244).

(3) $\|E\| = \lambda p : p \text{ is e-Given. } p$

Alternatively, again, (3) could be rephrased using Rooth's (1992a, b) terminology, thus yielding a formula like in (4).

(4) $\|E\| = \lambda p : p \text{ satisfies the Focus Condition on Ellipsis (2). } p$

If E is defined semantically, then, as a result, the licensing process, concerned with the local featural requirements that E involves, and the identification process, that is, the semantic conditions that E exerts on either its complement or the maximal projection on whose head it is placed, are related in one single feature, thus linking the two basic processes involved in the derivation of ellipsis.

Due to the locality restrictions between the E-feature and the deleted constituent, the licensing process is thus accounted for. In Merchant's (2001), moreover, a cross-linguistic variation of elliptical structures is accommodated, in that the features against which the E-feature is checked may vary from language to language.¹¹⁷

8.1.3. The Phonology of the E-Feature

Merchant (2004: 671) suggests that despite the cross-linguistic variation in the syntactic configuration of the E-feature, the phonological effect of the E-feature can be considered to be uniform. More specifically, in Merchant's definition, the E-feature triggers phonological deletion of the complement of the head on which it is placed. For Sluicing, which is conceived to be TP deletion, for instance, the effect of the E-feature can be summarised as in the rule in (5) below (Merchant 2004: 671, his (35)). φ_{TP} in (5) indicates the material that the TP node dominates.

(5) *The Phonology of E*

$$\varphi_{TP} \rightarrow \emptyset/E_$$

¹¹⁷ As Merchant (2001: 61) puts it: "Note that this particular implementation leaves open the exact nature and number of the checking features, and the requirements of E to be checked, allowing for cross-linguistic variation in this domain if necessary."

The E-feature thus bears an instruction to the phonological component to not parse the complement of the head on which the E-feature is placed, that is, the concept of deletion can be captured in terms of non-pronunciation of material at the PF level. As Merchant (2004: 671) points out, there is thus no syntactic process of deletion involved. On the other hand, the information that deletion will take place in the PF component is made available in the syntax already, since the licensing head of the elliptical structure (at least in Merchant's conception of the E-feature) is merged with the E-feature in syntax. For Sluicing, for instance, it is the complementiser C that merges with E, yielding TP deletion (Merchant 2004: 672).

In the next part of this chapter, I will provide some examples of how different types of elliptical structures can be captured with a variety of E-features, as assumed in Merchant's (2001, 2004) analysis.

8.2. The E-Feature in different Elliptical Structures

In this section, I will illustrate how the E-feature is implemented in different instances of ellipsis.

8.2.1. The E-Feature in Sluicing

In Sluicing, for which Merchant's (2001) analysis is mainly intended, the E-feature is a feature that is placed on the head I. Given the assumption that feature checking involves movement, the E-feature moves from I to C in Merchant's analysis, there being checked against the [+wh,+Q] feature on the C head. As a result, deletion of the sister of C is triggered, and we obtain Sluicing, that is, IP Ellipsis, at the PF level.

Merchant (2001: 60, fn. 12) notes that raising of the feature up to the licensing head C is not the only way to derive the appropriate configuration to license the PF deletion – alternatively, the E-feature could be placed on C immediately, being subject to a “feature compatibility requirement” (ibid.). As we will see below, this is precisely the line of argument that I will pursue in my own analysis.

Consider the Sluicing example in (6) (Merchant (2001: 3, his (1a), \emptyset indicating deleted material).

(6) Jack bought something, but I don't know what \emptyset .

Recall that the E-feature is defined such that it instructs the grammar to delete the lexical material situated below the head bearing the E-feature at the PF level. Merchant (2001) proposes, accordingly, that the Focus Condition for Sluicing is defined as in (7) (Merchant 2001: 31, his (62)), and works as illustrated in (9) and (10) for the example given in (8), according to the configuration in Merchant (2001: 57, his (60)).

He assumes that Sluicing is TP (IP) deletion, with the elided structure given in (8).¹¹⁸

(7) *Focus condition on TP-Deletion (Sluicing)*

A TP α can be deleted only if α is e-GIVEN.

(8) Jack bought something, but I don't know what [~~Jack bought t~~].

More specifically, the E-feature in Sluicing is specified as being [+wh,+Q]. It is generated in T (cf. (9)) and moves up to C (cf. (10)), where its *wh*-feature is checked. In C, it then instructs its sister node, <TP>, to delete, yielding the Sluicing example in (8).

(9)

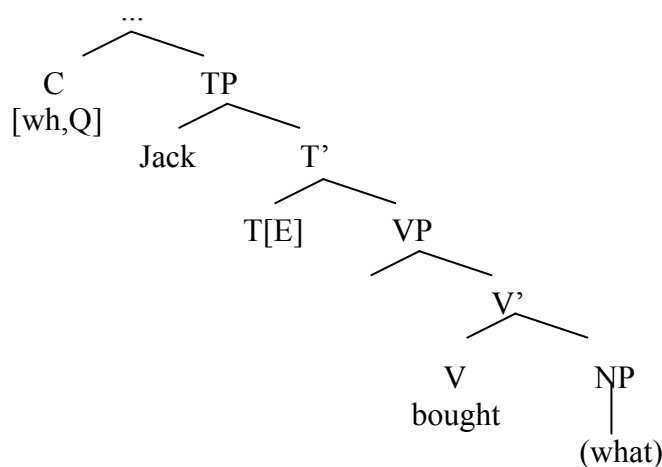

¹¹⁸ Concerning the status of TP deletion as deletion of syntactic structure, I refer the reader to the discussion of possible counterarguments in Chung, Ladusaw & McCloskey (1995).

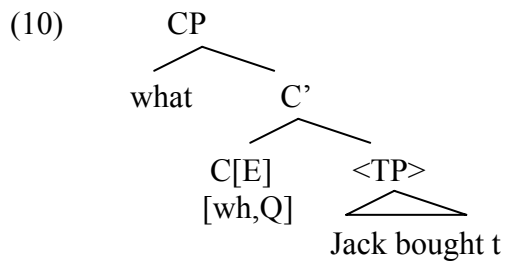

8.2.2. The E-Feature in Fragments

In fragment answers, illustrated in (11) (Merchant 2004: 673, his (37)), the relevant feature is defined on the basis of the structure given in (12).

- (11) a. Who did she see?
 b. John.
 c. She saw John.

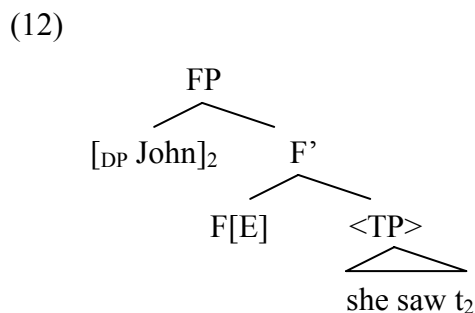

The fragment *John* moves to a functional projection above TP, and TP is deleted. The E-feature in question, placed on the head, is specified simply as in (13) (Merchant 2004: 675), with the subscript *f* specifying that the E-feature is the variety found in Fragments.

- (13) $E_f [uF^*]$

Merchant (2004: 675) suggests that the functional projection in question is actually Rizzi's (1997) focus phrase. He proposes, too, that the movement involved in fragment answers is A-bar-movement, with the properties usually identified for focus-driven movement. If this is true, the feature that the E-feature is checked against in fragment answers could actually be a focus feature F.

8.2.3. The E-Feature in VP Ellipsis

Following, among others, Lobeck's (1995, 1999) analysis, Merchant (2007: 9) contends that VP Ellipsis is licensed by the presence of a head T above the ellipsis site. Thus, in his analysis, the E-feature must be placed on T as the licensing head, deleting the complement of TP, namely, VP. In these terms, we may define the E-feature for VP Ellipsis as in (14) below.

(14) $E_{VPE} [T]$

However, given current phrase structure assumptions that include the presence of a vP projection above the VP, and given Merchant's (2006, 2007) observation that VP Ellipsis allows voice alternations between the antecedent and the elided clause, Merchant (2007) suggests that the E-feature rather be placed on the Voice head, that is, on v rather than on TP. In this configuration, the complement of the Voice head v , the VP, can be deleted straightforwardly. Accordingly, the specification for the E-feature should be as in (15) below rather than in (14) above.

(15) $E_{VPE} [Voice]$

8.2.4. The E-Feature in Pseudogapping

In this section, I will discuss the E-feature in the derivation of Pseudogapping. For Pseudogapping, one might assume a definition such as in (16) below, if one adopts Lasnik's (1995a, 1999a) analysis of the EPP.

(16) $E_{Psg} [EPP_{Obj}^*]$

If, however, one adopts the analysis put forward in this dissertation, we may implement the E-feature for Pseudogapping like Merchant himself has specified it on the basis of Jayaseelan's (2001) and my own (Gengel 2006a) analysis. Merchant (2006) suggests that the feature that is interacting with the E-feature in Pseudogapping should be a focus feature, since the remnant in Pseudogapping moves to the specifier of a Focus Phrase above (or instead of) vP in the analyses that I just mentioned.

In particular, Merchant (2006: 9) assumes that the head bearing focus – the $X[\text{foc}]^0$ head in Merchant's notation – in English is specified such that it has an E-feature. This combination of E on the $X[\text{foc}]$ head will thus trigger the deletion of the complement to the $X[\text{foc}]$ head, namely, vP in Pseudogapping.

Thus, the corresponding definition for the E-feature in Pseudogapping would be as in (17) below.

(17) $E_{\text{Psg}} [\text{Foc}]$

8.3. The E-Feature, E-Feature Raising, and Verb Raising

In this section, I will first compare the two options of placing the E-feature as proposed in Merchant (2001, 2006), that is, either feature movement of the E-feature to the licensing head, or the direct merge of the E-feature with the head licensing the respective ellipsis construction. In Merchant (2001), as outlined above, the first option is assumed, notably for Sluicing, while in his later work (Merchant 2006, 2007) the latter option seems to be favoured. Taking a closer look at the advantages and disadvantages of the respective solutions, I will conclude that feature movement of the E-feature is no longer necessary in current terms of syntactic theory.

8.3.1. Feature Raising of the E-Feature

Recall from the discussion in section 8.2.1. above that the E-feature in Sluicing is placed on the head of the projection that is deleted, namely, on the head T, from where it moves to C to be checked against the $[+\text{wh}, +\text{Q}]$ feature. In the current syntactic framework, this movement is no longer required, since feature checking with the appropriate features can also be achieved in a non-local configuration. From this point of view, the question arises whether feature movement of the E-feature is still necessary.

In a sense, though, this idea of placing the E-feature consecutively on the deleted element and on the licensing head maintains the relation between the licensing process involved in ellipsis

and the actual deletion process. Nonetheless, even without feature movement, this local relationship is not lost if the feature is assumed to be placed immediately on the head licensing the deletion of its complement. This, in fact, is the line suggested in Merchant (2001) as a potential alternative, and adopted in Merchant (2006, 2007).

Placing the E-feature that licenses the relevant type of elliptical structure directly on the head that is licensing the respective deletion as such is quite straightforward. In this configuration, the original local relationship between the licensing head and the actual ellipsis site is maintained (as it would be in a feature movement account). The advantages of this theoretical approach are the following.

First of all, the variation across languages with respect to their potential to license elliptical structures would thus not hinge on the redundant material itself but rather on the context in which ellipsis can be licensed in a given language. This seems certainly true in the case of VP Ellipsis or Pseudogapping, two constructions that are highly restricted in their occurrence in the world's languages, an observation that seems to bear directly on the differences in the auxiliary systems of the respective languages.

Secondly, if one wishes to treat constructions where the verb remains as VP Ellipsis, for instance, in Irish, where the verb has left the VP, placing the E-feature on the licensing element rather than on the element to be deleted itself accounts for the possibility that VP deletion may proceed quite independently of the actual presence of the verb, as long as the verb does not remain inside the deletion site, VP.

A third advantage surely lies in the straightforward derivation of the restriction that only constituents can be targeted by ellipsis. Given that deletion in terms of the E-feature is fundamentally based on a complement, that is, sisterhood relation, it is made sure that only constituents can be elided.

8.3.2. The E-Feature and Verb Raising

In previous work (e.g. Gengel 2006a), I suggested that it is possible to place the E-feature on the element that is deleted rather than on the head licensing the ellipsis. While this approach

has the important disadvantage of not sufficiently restricting the occurrence of elliptical construction, if the E-feature is severed from the actual licensing head, there was one reason why an approach in terms of placing the E-feature on V in Pseudogapping, and redefining the E-feature such that it targets the maximal projection of the head on which it is placed (cf. Gengel 2006a for a detailed account), is promising.

Recall that Lasnik (1995a, 1999a) assumed that the verb does not seem to raise from V to *v* in Pseudogapping. If the E-feature is conceived as I did in previous work, placing the E-feature on the verb V establishes a direct relationship between the raising of the verb and the deletion of the verb.¹¹⁹ Consider the Pseudogapping sentence in (18) below, with the relevant structure in (19) below.

(18) John will invite Susan, and Mary will Jane.

If the E-feature is placed on V, as indicated in (19) below, this would provide a natural explanation to why the verb does not raise, since it is specified for deletion.¹²⁰

In the example of VP Ellipsis in (20) below, given by Merchant (2006: 4, his (5)), the E-feature is placed directly on *v*, to derive VP Ellipsis, i.e. elision of the complement of the Voice head *v*. One would thus have to assume that the verb does not raise to *v*, given the presence of E on the voice head.

In Pseudogapping, the same reasoning could apply, with the E-feature on *v* blocking verb movement to that position, and resulting in VP deletion.

¹¹⁹ Later on, we will see, though, that this can also be captured with Merchant's definition of the E-feature, as a direct consequence of his account of Pseudogapping vs. VP Ellipsis in Merchant (2006, 2007).

¹²⁰ But see the discussion in the following sections for possible implementations of how the E-feature projects to accommodate settings in which more than just V is deleted. Thanks to Howard Lasnik (p.c.) for valuable comments regarding this issue.

(19)

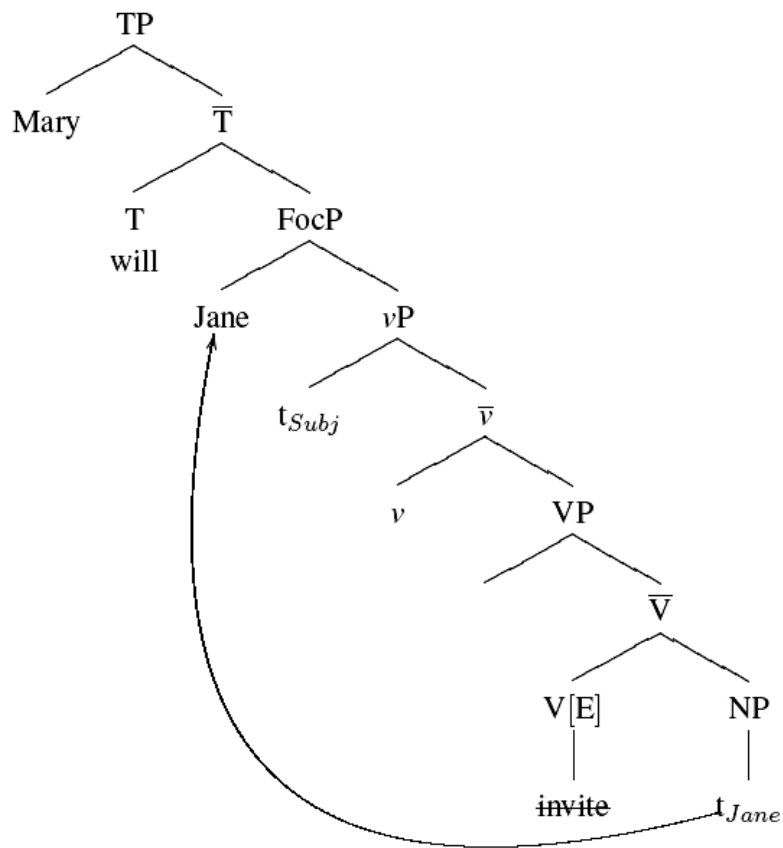

(20)

a. Bill shouldn't remove the trash—the janitor should.

b.

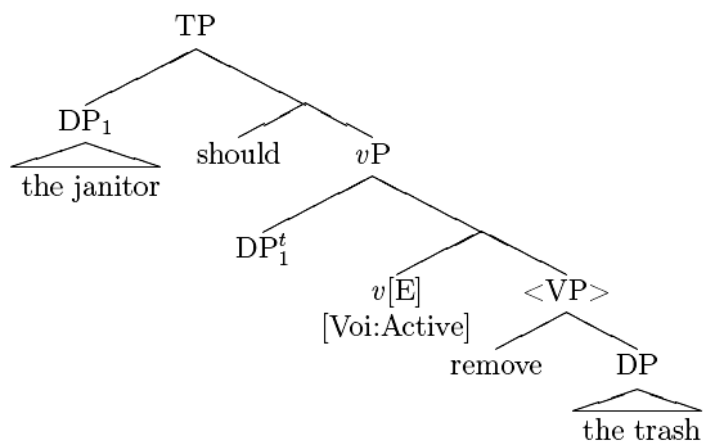

The presumed relationship between Verb Raising and elision of the verb can thus be summarised as in (21) below, based on the assumption that the verb either raises or deletes (cf. also Boeckx and Stjepanović 1999 for similar ideas). The ‘V-feature’ is the feature that triggers verb raising in general.¹²¹

(21) <u>V-feature</u>	<u>E-feature</u>
+V	- E
- V	+E

The complementarity of V-Raising and VP ellipsis could thus either be derived on the assumption that [E] is located on the V head and prevents movement of the verb out of the VP, or else, that the E-feature on the Voice head blocks movement of the Verb to the Voice head *v*.

This parallel, however, breaks down if one assumes with Merchant that in Pseudogapping, it is the *v*P that is elided in Pseudogapping, and not the VP as in VP Ellipsis (cf. Merchant 2006, 2007), as we will see in what follows.

Suppose that in Pseudogapping, *v*P is deleted. Then, according to Merchant’s definition of the E-feature (Merchant 2001, 2006), the ellipsis site could not be *v*P if the E-feature is placed on the head *v*, since in this case, just as in VP Ellipsis, the complement of the *v*P would be targeted by deletion, i.e. VP.¹²² Thus, the E-feature in Pseudogapping, as suggested in Merchant (2006: 9f.), has to be placed on the head above *v*P, that is, on the head of the Focus projection illustrated in (23) (ibid., his (8)) below, to target deletion of the entire *v*P.

If there is no E-feature on the Voice head *v*, however, the movement of the Verb from V to *v* is not ruled out by the presence of the E-feature in the relevant part of the structure. If, however, the E-feature is placed on the Focus head, as indicated in (23), and *v*P is deleted, verb movement from V to *v* becomes irrelevant, even if the lack of verb movement can no longer be explained with the E-feature.

¹²¹ Unfortunately, I have nothing specific to say about the nature of this ‘V-feature’. Still, the correlation between the two features seems worth pointing out.

¹²² Unless, of course, one would resort again to the strategy of eliding the maximal projection containing the head with the E-feature, as suggested in Gengel (2006a, a.o.).

(22) Some brought roses, and others did lilies.

(23)

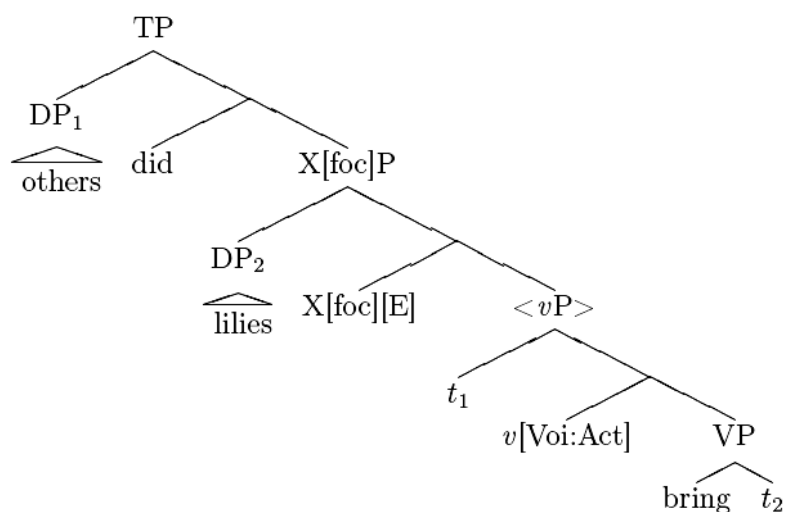

In sum, then, the verb raising parameter can be stated as follows. If verb movement were taking place to a position that hosts the E-feature, this verb movement should be blocked, as is the case in VP Ellipsis. The actual blocking of the verb movement could be paraphrased in terms of the E-feature, that is, the verb should not raise to a position where the E-feature is merged (presumably for reasons of economy). If, on the other hand, the Voice head does not bear an E-feature, the verb moves from V to *v* without fail, even in structures like Pseudogapping, where it had previously been assumed that there is no verb raising at all (Lasnik 1995a, 1999a, a.o.).

The paradoxical conclusion to be drawn from this section is thus the following: by giving a different structural account for Pseudogapping and VP Ellipsis, the former construction becomes more similar to non-elliptical sentences with respect to verb raising, but less similar to VP Ellipsis in precisely the same respect.

The only straightforward way to overcome this problem that I see at the moment is to assume that once an E-feature is present in the structure, higher than or on Voice itself, verb raising becomes unnecessary since the relevant part of the structure is immediately specified for deletion. This assumption then would yield the desired result of treating VP Ellipsis and

Pseudogapping on a par, potentially only diverging in the size of the actual ellipsis site, without further consequences for the occurrence of verb raising in either construction.

As we will see in the next section, the process of evacuating material out of the VP can be linked to the E-feature.

8.4. The E-Feature and Focus

Recall the definition of the E-feature in section 8.1 of this chapter. There, with regard to the semantics of the E-feature, I proposed that it could be stated as follows (24) (cf. (2) above).

(24) *Focus Condition on Ellipsis (Final Version)*

A constituent α in XP_E can be deleted only if there is an XP_A , where

- (i) $\|XP_A\|^o$ either is or implies an element of $\|XP_E\|^f$, and
- (ii) $\|XP_E\|^o$ either is or implies an element of $\|XP_A\|^f$.

If the E-feature is now defined as obeying this Focus condition on Ellipsis (as informally rendered in (4) above), the condition on which material can be elided is defined in terms of focus, or rather, the absence of focused material in the elided part of the clause.

On the basis of the assumption that non-given material cannot be deleted, I propose that the E-feature be sensitive to the notion of Givenness or focus, thus interacting, as I assume for Pseudogapping, for instance, with the focus feature on the remnant.

Similar to the E-feature, which is based on focus in the definition I proposed, or on Givenness in Merchant's analysis (2001, and subsequent work), the focus feature on the remnants in ellipsis also relies on information structure by its very nature.

Capitalising on this information-structural dimension of the two features, treating them as two sides of the same coin, with one targeting non-focused material, and the other one marking focused material, the definition of the E-feature could thus be complemented with a contrastiveness or focus requirement on the ellipsis *remnant*. Accordingly, one could modify

the descriptive definition of the E-feature in (4) above as in (25) below (on the basis of the *Focus Condition on Ellipsis* in (24) above).

(25) $\|E\| = \lambda p : p$ satisfies the Focus Condition on Ellipsis. p
and E does not apply to focused (F-marked) material.

This second part of the definition can be understood as both a semantic and syntactic requirement. On the semantic side, it is fairly clear, if not implicit in our understanding of the E-feature and ellipsis as such. However, the requirement also has a syntactic side to it, since, as the E-feature specifies the deletion of the syntactic complement of the head on which it is placed, no focused material should be (or remain) within the syntactic domain of the E-feature.

While this sensitivity of ellipsis to the presence of focused material can be captured via including the link to the Focus feature in a complementary definition, the Focus feature, the E-feature as such has an effect on the Focus feature, as I argue for in this dissertation.

This becomes obvious if we compare elliptical constructions with their deaccented counterparts. Following Rooth (1992a, b), the focus structure of the remnants of deaccented and elided structures is quite similar. However, if the verb is not deleted in the non-elided counterpart of Pseudogapping, for instance, there is no need to move the focused remnant out of the VP, and, presumably, no Focus position above the VP layer is projected. It seems, then, that the E-feature has an effect on focused material once this focused material is situated in the domain of the E-feature, and requires the focused material to move out of the deletion site.

Thus, the E-feature and the Focus Feature interact to yield a movement and deletion account of ellipsis. Given the presence of the E-feature, focus movement, which does not take place in English otherwise (as traditionally assumed, though see chapter 6 for exceptions to this generalisation (cf. Jayaseelan 2001)). If the E-feature does not allow the presence of focused material inside the part of the structure that it specifies for deletion, the contrastive or focused material has to be moved out prior to deletion, which is in keeping with the approaches discussed in previous chapters that also assume movement of the remnant out of the ellipsis site prior to deletion.

Before I move on to illustrate the interaction of the E-feature and the Focus feature in Pseudogapping, and extend the analysis proposed there to other elliptical structures, I will briefly discuss the connection between the \sim operator, assumed in Rooth's analysis (e.g. Rooth 1992a, b), and the E-feature.

8.5. The E-Feature and the \sim Operator

Recall that Rooth (1992a, b) provides a focus account in terms of the \sim operator, which obeys the Focus Interpretation Principle in (26) (cf. Rooth 1992: 86).

(26) *Focus Interpretation Principle*

In interpreting focus at the level of a phrase α , add a constraint that:

(*contrasting set*) $\Gamma \subseteq \|\alpha\|^f$, or

(*contrasting individual*) $\gamma \in \|\alpha\|^f$.

Γ is a variable with the type of a set of objects matching α in type, and γ is a variable matching α in type.

In a sense, this Focus Interpretation Principle in (26) thus incorporates the contrastiveness or focus principle that is relevant in ellipsis.

Moreover, Rooth also suggests in his paper on ellipsis (Rooth 1992b) that the \sim operator can equally account for the marking of redundancy, as illustrated in the example in (27) (Rooth 1992b:3, his example (4)), where the \sim operator indicates that the argument to the left of the \sim operator, i.e. *semantics*, is redundant with respect to the argument on the right of the \sim operator, i.e. *semantics* in the first clause. This relationship is illustrated with the index 8 for the argument on the right of the \sim operator.

(27) We are supposed to take statistics and [semantics]₈ this term, but I don't [like
 [[semantics] \sim 8]]

Rooth suggests (1992b: 10) that the semantic redundancy constraint captured by the \sim operator, illustrated in (26) above, might be linked to a syntactic constraint that he assumes to

be active in ellipsis cases, thus yielding the distinction between ellipsis cases and deaccenting cases. In sum, then, Rooth (1992b) proposes that the \sim operator serves two purposes, one being the licensing of ellipsis, and the other one being the licensing of contrastive focus.

This dual purpose of the \sim operator, along with the assumption of there being a syntactic constraint that is at work in ellipsis, permits us to draw a connection between the \sim operator, as conceived by Rooth, and the E-feature analysis discussed above. In the definition of the E-feature, the redundancy relation can be captured in terms of the Focus Condition on Ellipsis, as repeated in (28) below.

(28) Focus Condition on Ellipsis (*Final Version*)

A constituent α in XP_E can be deleted only if there is an XP_A , where

- (i) $\|XP_A\|^0$ either is or implies an element of $\|XP_E\|^f$, and
- (ii) $\|XP_E\|^0$ either is or implies an element of $\|XP_A\|^f$.

If one includes the constraint noted in (26), thus accounting for the contrastiveness on the remnant, the second requirement for the E-feature could be stated such that the E-feature does not apply if there is a contrasting element $\gamma \in \|\alpha\|^f$ in its syntactic domain. (Once this element is moved out of this domain, the E-feature may apply.) Thus we can recast the definition given in (25) as in (29) below, replacing α (in (26)) with the antecedent, XP_A .

(29) $\|E\| = \lambda p : p$ satisfies the Focus Condition on Ellipsis. p

and $\neg \exists \gamma \in \|XP_A\|^f$ in the domain of E.

In a sense, then, the \sim operator as proposed in Rooth's (1992a, b) analysis can be paraphrased as two syntactic features, namely, the E-feature which can incorporate both the licensing of redundant material and the prohibition of focused material in its domain of impact, and the Focus Feature, marking an element as contrastive as in the Focus Interpretation Principle in (97) above. The E-feature, as outlined above, is sensitive to the F-marking on contrastive material in its domain, which makes the two features, the E-feature and the Focus feature, conspire in the case of ellipsis, thus reflecting the dual purpose that Rooth (1992b) assumed for his \sim operator.

8.6. The Size of the Elided Phrase

In the remainder of this chapter, I will be concerned with the question of what part of the structure is deleted in the different elliptical configurations described above, and show that the size of the elided phrase can be reflected in a phase-based theory of syntax.

8.6.1. Phase-Based Deletion at the ν P Level

In order to determine the final size of the deleted structure, one issue that needs to be addressed with respect to the ν P layer is the question of verb movement. The standard assumption is the one that Lasnik (1999, a.o.) also presumed, namely that the verb moves from V to ν in the syntactic derivation of non-elliptical constructions. He suggested, however, that Pseudogapping differs from other constructions in that the verb does not raise to ν (or to Agr_O in his terms).¹²³

While, at first glance, the movement of the verb to ν would only bring about a formal decision between two possible sites of deletion, i.e. deletion of the VP, or rather deletion of ν P, recent work by Merchant (2006) shows that voice alternations could serve as an argument to decide between the two options in question, as we will see in what follows.

If the entire ν P is deleted, then, obviously, the question about verb movement from V to ν is obsolete. If, however, only the VP is deleted, then a mechanism must be found to account for the non-raising of the verb. One solution to this problem that I suggested in previous work (Gengel 2006a) would be to assume that the E-feature, since it specifies an element for deletion, blocks the movement of the element marked with this feature.

One empirical difference between VP Ellipsis and Pseudogapping, however, that turns out to be crucial for the size of the deletion site is the status of voice alternations (cf. Merchant 2006).¹²⁴ Merchant observes that VP Ellipsis allows differences in voice between the

¹²³ More specifically, in Lasnik's analysis the features of the verb are moved and checked, but the lexical content of the verb fails to be pied-piped. Thus, to prevent the derivation from crashing at PF, the VP is deleted.

¹²⁴ It should be noted at this point that speakers' judgements concerning these voice alternations are still far from conclusive. Nevertheless, most people detect a clear contrast between VP Ellipsis and Pseudogapping, which is why these examples should be taken into account.

antecedent and the elided clause ((30) and (31)), whereas Pseudogapping does not ((32) and (33); though see Coppock 2001 for diverging judgements).

(30) The system can be used by anyone who wants to. <use it>

(31) Actually, I have implemented it [= a computer system] with a manager, but it doesn't have to be. <implemented with a manager>

(32) *Hundertwasser's ideas are respected by scholars more than most people do his actual work. <respect>

(33) *Laypeople respect Hundertwasser's actual work more than his ideas are by scholars. <respected>¹²⁵

Taken at face value (though see fn. 124), these data suggest that Pseudogapping and VP Ellipsis differ with respect to the portion of the structure that is deleted: VP Ellipsis needs the voice head to be intact (although no verb movement can then be assumed) and targets VP, whereas Pseudogapping might delete the full *v*P, irrespective of verb movement from V to *v* (cf. the more detailed discussion in chapter 9).

Another indicator of the size that is targeted by deletion in the VP domain is due to the status of 'again' in the context of VP Ellipsis. Johnson (2004), who claims that VP Ellipsis targets the full *v*P (not only the VP, cf. the in chapter 9), provides the following argument to support his hypothesis.

With 'again', there are two readings available in the non-elliptical context, which is illustrated in (34) below (Johnson 2004: 8, his (24)).¹²⁶

(34) She closed the door again.

a. She closed the door, and someone had closed it before. (*repetitive reading*)

b. She closed the door, and it had been in that state before. (*restitutive reading*)

¹²⁵ All examples are taken from Merchant (2007: 2f., his (1) to (4)).

¹²⁶ It seems, though, that the repetitive reading is more difficult to get (Howard Lasnik, p.c.).

(34)' Jane closed the door, and then Maribel did again.

In VP Ellipsis (34') (cf. the structure in (37) below), by contrast, only the repetitive reading is available (Johnson 2004: 9). His argument runs as follows. The repetitive reading is available only when *again* modifies the *vP*. The *vP* is supposed to denote the event as such, whereas the VP denotes the resulting state. As a consequence, if the VP is modified by *again*, this results in the restitutive reading.

The sentence pair in (35) and (36) below illustrates the contrast between the two readings, where the repetitive reading is favoured in (35) (Johnson 2004: his (27)), and blocked in (36) (ibid., his (28)).

(35) Jane closed the door, and then Maribel closed it again.

(36) The wind blew the door open, and no one closed it. Finally, Maribel closed it again.

In the VP Ellipsis counterparts of (35) and (36), there is a clear difference: while (35) turns out to be grammatical in VP Ellipsis, as shown in (37), (36) is completely unacceptable, as illustrated in (38) below (both examples from Johnson 2004: 9, his (29) and (30)).

(37)

Jane closed the door, and then Maribel did

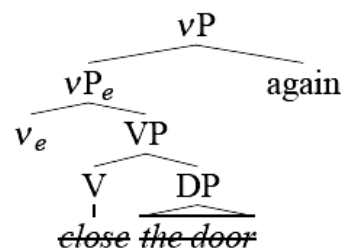

(38)

The wind blew the door open and no one closed it.
Finally, *Maribel₁ did

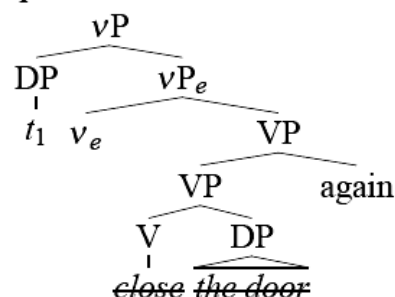

Thus, Johnson (2004: 9) concludes that VP Ellipsis actually deletes the full *vP*, not only the *VP*, as this would be the only way to strand *again*. He argues that therefore, *again* necessarily modifies a constituent that is larger than the *VP* alone, that is, in his account, in VP Ellipsis, *again* modifies the *vP* and not the *VP*.

For Pseudogapping, in turn, the voice alternations discussed above suggest that Pseudogapping could be analysed as deletion of the full phase *vP*. This, however, depends on whether we assume that the object remnant in Pseudogapping moves to the outer specifier of *vP* (as suggested by the views in Chomsky 2005), or to a focus position above *vP* (following Jayaseelan 2001). If the object moves to a Focus Phrase above *vP*, the full phase could be deleted. However, as the structural configuration as suggested in Chomsky (2005) can also account for the A-bar properties of the remnant, this structure might be preferable, since it does not involve an extra focus projection.

The two configurations would be as in (39) for the full phase deletion, and as in (40) below for the deletion of part of the phase, with the Pseudogapping object in the outer specifier of *vP*. Since the two specifiers of *vP* are linked to one *v* head, there seems to be no possibility to delete only one specifier of *vP*.

(39)

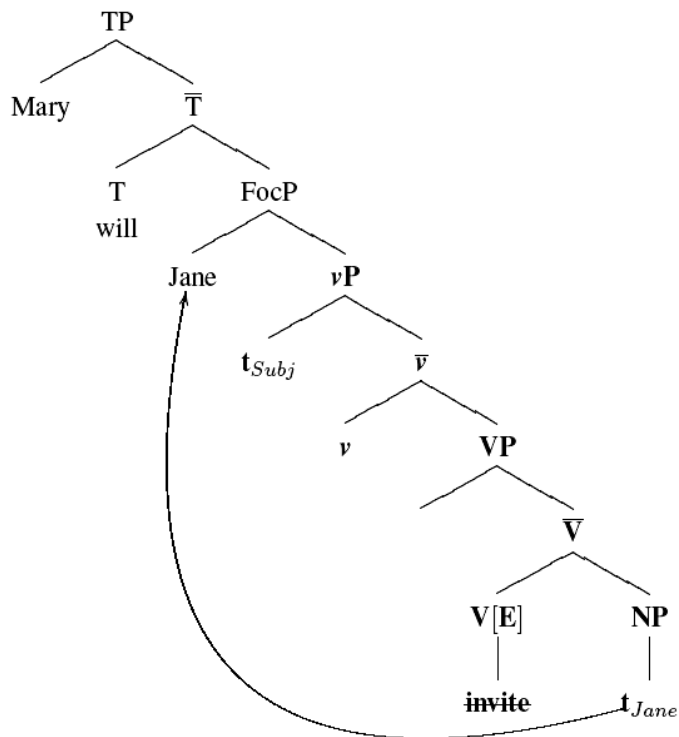

Thus, the assumption that the outer specifier of vP hosts the object remnant in Pseudogapping (in (39) above) supports the view that only the *domain* of the phase, i.e. only VP for the phase vP , is deleted, since the vP would contain focused material, which, by the definition of ellipsis in general, can never be deleted.

(40)

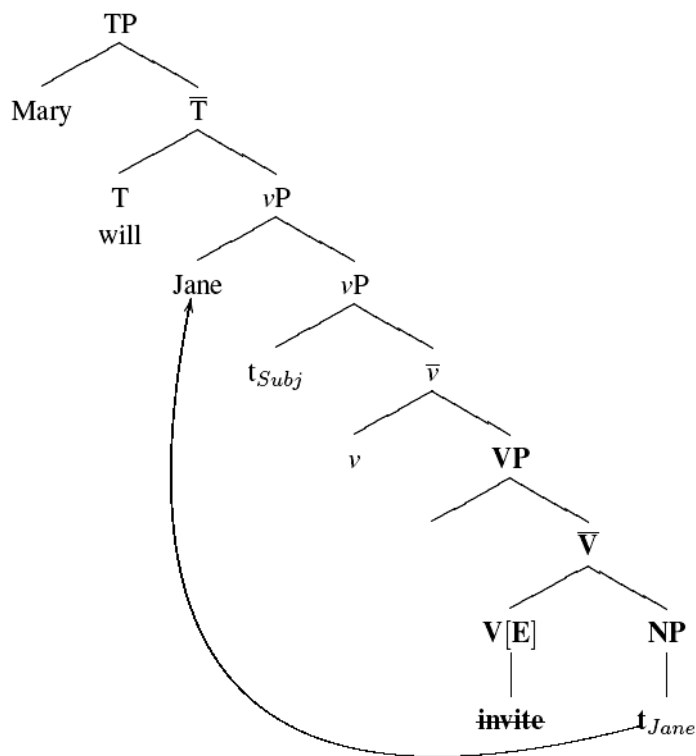

The hypothesis that only the domain of the phase is targeted by deletion allows us to draw a connection between Spell-Out and ellipsis, since it could be possible to treat ellipsis as a case of non-Spell-Out of existing structure. This assumption establishes a general choice between phonological Spell-Out and non-Spell-Out, i.e. ellipsis.

Furthermore, the movement of remnants to the phase edge receives further justification: it can be treated as another instance of movement of elements that are used later in the structure to the phasal edge (in this case, elements move to the phasal edge to escape the deletion site).

This conclusion would then treat VP Ellipsis and Pseudogapping in a similar fashion. In both instances, only the VP is deleted, and verb movement from V to *v* is prohibited by the presence of the E-feature on V.

8.6.2. Phase-Based Deletion at the CP Level

If it were possible to delete full phases, we would expect deletion of the entire CP in Gapping and Sluicing. However, it is hard to see how full CPs could be targeted by deletion, since under the account proposed above both subject and object end up in the left periphery.

As both Gapping and Sluicing arguably involve TP deletion, the idea of the deletion of full phases could still be maintained if we assume TPs to be phases in their own right. However, this is not an uncontroversial claim. Chomsky (2005) in particular argues that there is no need to assume a TP phase alongside the (less controversial) CP phase.

In analogy to what I proposed for the ellipsis cases at the *v*P level, deletion also seems to target the domain rather than the entire phase at the CP level. If we consider TP to be the domain of the CP phase, both Sluicing and Gapping can be accounted for. This is in accordance with the Spell-Out mechanism assumed in Chomsky (2001, 2005). The domain of the phase is spelled out, i.e. for the CP phase, TP is sent to Spell-Out - or, as it happens in ellipsis constructions, not spelled out.

8.7. Auxiliaries and Deletion

In this section I discuss VP-Ellipsis and Pseudogapping with respect to the size of the deletion sites that can be assumed with regard to the distribution of auxiliaries. The empirical observation that VP-Ellipsis allows the occurrence of more than one auxiliary in the second conjunct, whereas Pseudogapping strongly prefers to have only one remaining auxiliary, poses a problem for a Pseudogapping derivation in terms of VP-Ellipsis. I argue that a VP-Ellipsis account of Pseudogapping, where the object vacates the VP before the VP is deleted, can be maintained, and that the difference with regard to the auxiliaries can be explained if movement is treated as having a special influence on the size of the deletion site, maximising it, and prohibiting non-focused material within the ellipsis site – constraints that need not be obeyed in VP-Ellipsis, where no movement process is involved.

8.7.1. Multiple Auxiliaries in VP Ellipsis

In the following, I will thus concentrate on the property Pseudogapping shares with VP-Ellipsis, the presence of an auxiliary. There is one empirical difference between the two phenomena in this respect: Whereas VP-Ellipsis allows more than one auxiliary to occur in front of the deletion site (as in (41)), Pseudogapping seems to be restricted to only one, the finite auxiliary (42), which, according to many speakers, makes (42) less acceptable.¹²⁷

(41) José Ybarra-Jaegger should have eaten rutabagas, and Holly should have _ , too.

(42) ??José Ybarra-Jaegger should have eaten rutabagas, and Holly should have _ sandwiches.

This property is unaccounted for in VP-Deletion approaches to Pseudogapping; as also pointed out in Agbayani and Zoerner (2004).¹²⁸ Thus, I will try to explain why this difference should arise, and show that it can be accounted for even if we maintain a VP-Deletion analysis for Pseudogapping. Consider the data in (43) to (45) below.

(43) José Ybarra-Jaegger should have eaten rutabagas, and Holly should have _ , too.

(44) ??José Ybarra-Jaegger should have eaten rutabagas, and Holly should have _ sandwiches.

(45) José Ybarra-Jaegger should have eaten rutabagas, and Holly should've _ sandwiches.

This pattern is repeated in the sentences below, where (47) and (48) illustrate the ungrammaticality of Pseudogapping with more than one auxiliary.^{129,130}

(46) José Ybarra-Jaegger has been eating rutabagas, and Holly has been _ too.

¹²⁷ Example (41) is taken from Johnson (2001: 440), (42) shows the corresponding Pseudogapping case. The judgements of (42) vary. The sentence improves if the second auxiliary is deaccented.

¹²⁸ Thanks to Ian Roberts (p.c.) for bringing this problem to my attention.

¹²⁹ There seems to be some variation in judgements, however. From what I gathered from my informants, speakers of American English more readily accept it, whereas British speakers almost uniformly reject it.

¹³⁰ (46) is taken from Johnson (2001: 440), (47) and (48) were provided by Jonny Butler (p.c.).

(47) ??Susan will have invited Harriet, and Arthur will have _ Daniel.

(48) ??If Arthur has invited Daniel, then Susan must have _ Harriet.

These data allow the following correlation (49):

(49) *Multiple Auxiliaries in Pseudogapping*¹³¹

Multiple Auxiliaries in Pseudogapping are disallowed, except for the cases in which the second auxiliary is deaccented.

8.7.2. Structural Problems

In the analysis put forward in this dissertation, based on focus movement and VP deletion, the rather degraded status of (50) below, with the structure in (51) is quite unexpected.

(50) ??José Ybarra should have eaten rutabagas, and Holly should have _ sandwiches.

¹³¹ This correlation seems to hold for British English. A more thorough investigation of the dialectal differences between British and American English is, unfortunately, beyond the scope of this dissertation.

(51)

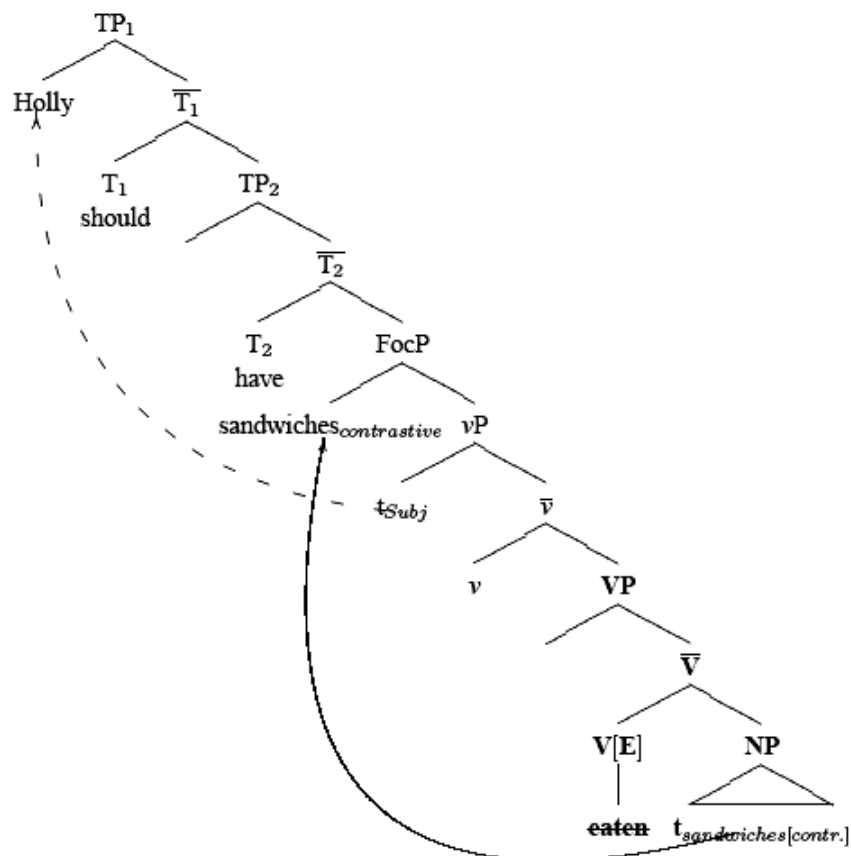

I suggest therefore that in order to cover cases of multiple auxiliaries, an additional requirement holds in the derivation of Pseudogapping, which can be described in terms of the *MaxElide* Principle (Merchant to appear), as we will see in what follows.

8.7.3. The Principle of *MaxElide*

Merchant (to appear) invokes a principle that is intended to capture the fact that if ellipsis occurs in a structure containing a *wh*-trace, it seems to target the largest constituent that can be elided. He phrases this constraint as in (52) (Merchant to appear: 8).

(52) *MaxElide* (Merchant to appear)

Let XP be an elided constituent containing an A'-trace.

Let YP be a possible target for deletion.

YP must not properly contain XP ($XP \subsetneq YP$).

This constraint is illustrated in the following sentence in (53) (Merchant to appear: 7, his (26c)).

(53) *They said they heard about a Balkan language, but I don't know which they did.

Here, XP is taken to be the VP <say they heard about t_a Balkan language>, and YP the corresponding IP <they did say they heard about t_a Balkan language>. As IP does indeed contain VP, i.e. YP contains XP, *MaxElide* holds, deleting the IP instead of the VP, which results in a grammatical sentence (54) (ibid., his (26b)).

(54) They said they heard about a Balkan language, but I don't know which.

8.7.4. *MaxElide* in Pseudogapping

This principle of *MaxElide* can also work in the case of Pseudogapping with multiple auxiliaries. Recall the sentence in (50), here repeated as (55).

(55) ??José Ybarra-Jaegger should have eaten rutabagas, and Holly should have _ sandwiches.

Here, the same pattern as in the cases of *MaxElide* illustrated above seems to obtain, albeit independently of categories such as IP and VP. But the principal insight can be maintained: instead of deleting <eaten>, the smallest possible deletion site, <have eaten> is preferred, yielding the standard Pseudogapping example with one auxiliary. Indeed, deleting even more, <should have eaten> is also possible, yielding the Gapping case, a construction that is generally given preference over the Pseudogapping construction (according to Levin 1986).

One crucial point of Merchant's definition is the presence of an A-bar trace.¹³² This can be applied to Pseudogapping, where we find A-bar-movement. If we take the movement responsible for the Pseudogapping derivation to be an A-bar-type movement (such as focus

¹³² However, this claim relies solely on empirical evidence (Howard Lasnik, p.c.).

movement, as proposed above), a direct connection between the occurrence of movement and the size of the deletion site can be established (56):

(56) *Movement-and-Deletion Generalisation*

- (i) *MaxElide* holds when A-bar-movement has taken place prior to ellipsis.¹³³
- (ii) Eliding the maximum amount of material maximises the contrast on the remaining elements.¹³⁴

In VP-Ellipsis, no such movement occurs, which correctly predicts that *MaxElide* does not hold, as illustrated by the grammaticality of (57).

(57) José Ybarra-Jaegger should have eaten rutabagas, and Holly should have _ , too.

(58) José Ybarra-Jaegger should have eaten rutabagas, and Holly should _ sandwiches.

Concerning the structural derivation of Pseudogapping (shown in (58)), we can assume the following. If indeed there are several auxiliaries stacked in the structure, they are in a layered structure, i.e. different TP layers or modal layers (see Butler 2004 for one implementation). These TP layers, presumably, come with their own heads and specifiers, hence providing landing sites for movement.¹³⁵

In Pseudogapping, then, the object may move from the specifier of the Focus projection, higher up to the specifier of TP₂ via A-bar-movement, as in (59) below.¹³⁶

Hence, in Pseudogapping, the object would move to a position just below the finite auxiliary, which encodes person and tense features that may differ from the auxiliary in the first clause. Since the restrictions on the occurrence of non-focused material seem to be stricter in movement environments, *MaxElide* obtains.

¹³³ I am aware of the fact that I depart from the original definition of *MaxElide* here. However, I think that the main insight is kept, which is why I keep the term *MaxElide*.

¹³⁴ This is especially obvious in the case of Gapping, which I will not discuss here. See also Gergel et al. (2007) for related discussion.

¹³⁵ Since only the highest T node is specified for finiteness, and an A-position, one could assume that the other specifiers don't necessarily have to be A-positions, i.e. could potentially be A-bar-positions.

¹³⁶ In principle, the Gapping derivation can also be explained along these lines, the main point being there that the subject has to vacate the [Spec,TP] position because it is contrastive. See Gergel (2006a) and Gergel and McNay (2006a) for an analysis along these lines.

(59)

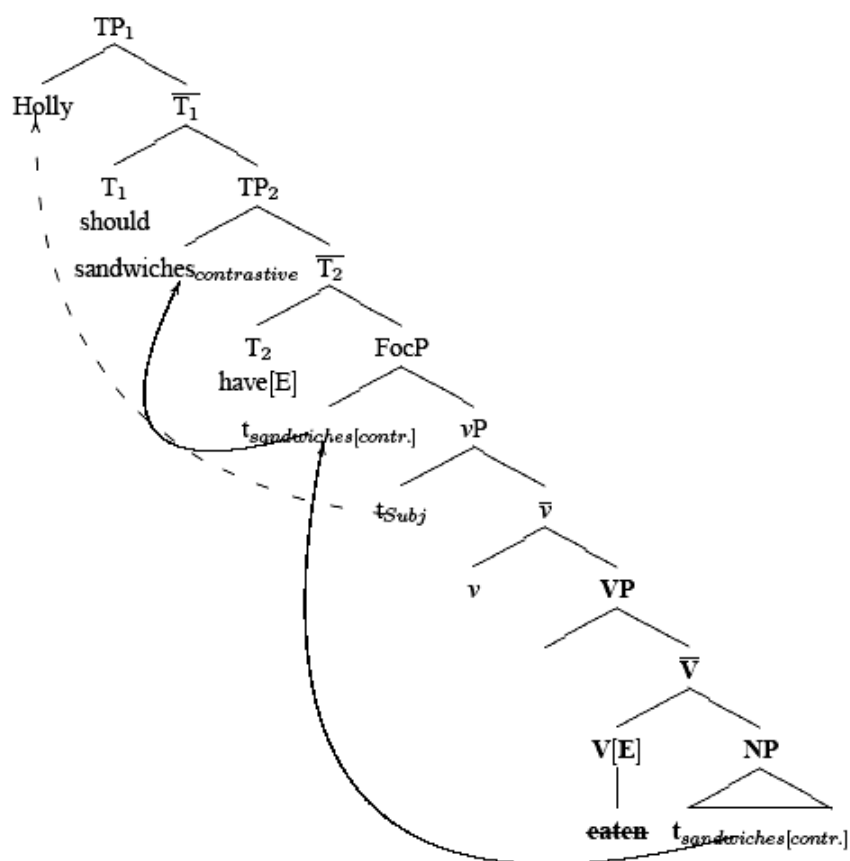

8.7.5. *MaxElide* and Deaccenting

As can be seen in the contrast between (60) and (61) below, the *MaxElide* principle does not necessarily entail the full deletion of the second auxiliary. The strongly deaccented version in (61) is acceptable to speakers who would rule out the not deaccented version in (60). The possibility of not only deaccenting but also contracting the second auxiliary could entail a process of cliticisation, achieving almost the same phonological results as the elided version.¹³⁷

(60) ??José Ybarra-Jaegger should have eaten rutabagas, and Holly should have _ sandwiches.

¹³⁷ This points to a less strict version of *MaxElide* in the case of SAI in comparatives, illustrated in section 5. Arguments supporting this view have been put forward in Gergel et. al. (2007).

(61) José Ybarra-Jaegger should have eaten rutabagas, and Holly should've _ sandwiches.

In the context of multiple auxiliaries and ellipsis, the MaxElide principle thus seems to be an efficient means to describe the difference between VP Ellipsis and Pseudogapping. However, in its full range, the observation that Pseudogapping allows only one element in front of the deletion site, is still only partly accounted for, requiring further investigation.¹³⁸

Before I conclude this chapter on deletion, I will discuss the phenomenon of PF deletion, which, in its various guises, is often assumed to repair structure that would otherwise result in an illicit configuration. I will briefly outline the main point of this line of argument in the next section, and show that the analysis put forward in this dissertation does not require taking recourse to the repair by deletion strategy.

8.8. Repair by Deletion

Lasnik (2005, and previous work) proposes that with respect to the verb in Pseudogapping, which fails to raise in Pseudogapping, according to his analysis, we may assume a repair-by-deletion approach. This is so since the verb in the Pseudogapping derivation moves only its formal features but fails to pied-pipe the lexical material.

In answer to the question why the verb does not raise in Pseudogapping, Lasnik (1999a, a.o.) assumes that once the feature F on the lexical V is attracted to the higher V, the lower V “becomes defective”, which causes either pied-piping or, in the case at hand, phonological deletion.¹³⁹

If the object moves to [Spec, Agr_O], the lower VP can be deleted, and the offending material will no longer be present at the PF level; hence, the derivation will go through. Thus, as Lasnik puts it, “[d]eletion provides another way to salvage the derivation. ... a PF crash is avoided and the result is acceptable Pseudogapping.” (Lasnik 2005a).

¹³⁸ Thanks to Judy Bernstein and Jane Grimshaw for very helpful discussions of this topic.

¹³⁹ Lasnik (1999b) notes that this is an application of Ochi's (1999) implementation of Chomsky (1995).

If head movement were to take place at the PF level, as also argued for in Boeckx and Stjepanović (1999: 351), this could explain why in Pseudogapping, the verb does not raise, whereas it does in non-elliptical sentences, in a quite different way. According to Boeckx and Stjepanović (1999: 352), head movement could interact with an ellipsis rule: if both operations are PF operations, they may actually compete and the verb either needs to move or be deleted if it doesn't.

This hypothesis, like Lasnik's (1995a, 1999a) analysis of feature crashing, relegates the crucial role of deciding whether a Pseudogapping derivation is grammatical or not, entirely to the PF level, keeping Lasnik's (1999a) insight that the key feature of Pseudogapping is the presence (or rather, absence) of verb movement.

The idea that ellipsis remedies structural violations that occur during the syntactic derivation figures prominently in other approaches dealing with ellipsis. In Kennedy and Merchant's (2000) analysis of Pseudogapping in comparative structures, for instance, there is a [+wh]-feature on an F^0 head inside the VP, which cannot be eliminated, and thus violates Full Interpretation. Thus, deletion here obviates the negative effect that this feature complex would have with respect to the constraints on the interfaces (for details, see Kennedy and Merchant 2000: section 4; and the short overview of the relevant structures in chapter 3 of this dissertation).

A related issue, where the effect of ellipsis as a repair strategy becomes most obvious, is the obviation of island effects in the context of deletion. In many cases, it seems that PF deletion is able to render island violations invisible, so to speak, but, unfortunately, not in all cases. This has led researchers to consider different kinds of islands, in view of the sensitivity to ellipsis operations (cf. Merchant 2004, to appear, for details regarding a classification of islands, and Fox and Lasnik 2003 for explicit arguments against a non-uniform treatment of islands). I will return to this topic in chapter 9, where I will illustrate the interaction between islands and ellipsis with the example of Sluicing and Fragments, which show interesting consequences with regard to the comparison of focus movement and regular *wh*-movement.

In the approach advocated in this dissertation, however, the salvaging effect of deletion does not play a significant role, if any role at all. If the movement in ellipsis comes down to removing material from a part of the syntactic structure that is specified for deletion, the

resulting structure in the ellipsis site is only offending to the interfaces in that it would contain non-focused material. The actual violation would thus not be caused by the material remaining inside the VP in Pseudogapping, but rather by the movement of the material out of the VP to a higher position in the structure, which destroys the surface order. In this sense, it seems to me that the only violation that might occur is in those cases where the object moved of its own accord, without subsequent deletion of the remaining structure. Since, unlike the movement assumed in a Lasnik-style analysis, however, the object movement is triggered by the presence of the E-feature itself, so to speak, this intermediate step should never arise. Thus, in contrast to Lasnik's (1995a, 1999a) approach, the movement of the verb in my analysis is directly linked to ellipsis, rather than being strictly linked to object movement. In dissociating the verb movement from the object movement, a potential violation of the syntactic configuration caused by the failure of the verb to move past the object is excluded, since the object movement would never take place unless the verb was specified for deletion.

8.9. Conclusion

In this chapter, I have provided an account of how deletion should be implemented in Pseudogapping, and other types of ellipsis. I have adopted, in its essence, Merchant's (2001) E-feature mechanism, and shown that it can be modified such that it incorporates the contrast condition that was established in the previous chapter. Thereby, I have linked contrast and ellipsis explicitly, and prepared the grounds for an interaction between the E-feature and the Focus feature in syntax, resulting in focus-driven movement out of phrases that are specified for deletion. Moreover, I have investigated the question of what the size of the ellipsis target actually is, an issue that has received some prominence in recent literature (Merchant 2006/forthcoming), due to the difficult status of voice alternations in VP Ellipsis and Pseudogapping. I have further discussed the question of multiple auxiliaries in front of the ellipsis site, concluding that this distribution may be due to the interaction with movement, other than being simply a pragmatic feature. Finally, I approached the topic of repair by deletion, which I interpreted such that it is not necessary in the strict sense in my own analysis, since the postulated interaction between movement and ellipsis ensures that elements move only out of the ellipsis site if this phrase is subsequently elided. Since this is only the case if there is an E-feature present in the structure, a violation, if it is assumed at all, is part and parcel of the account, rather than being a separate principle.

In the next, and final chapter of this dissertation, I will show that the combination of the E-feature mechanism and the Focus feature can account for different types of ellipsis, yielding an essentially uniform account of ellipsis.

9. Movement and Deletion: A Uniform Account of Ellipsis

In this chapter, I will provide a uniform account of a variety of elliptical structures, on the basis of the interaction between the E-feature and the Focus feature. I will begin with the Pseudogapping analysis, and show how it can be extended to cover other instances of ellipsis as well, thus providing a mechanism of movement and deletion to derive elliptical constructions.

9.1. Pseudogapping

Consider the Pseudogapping example in (1) below. The structure given in (2) illustrates the interaction between the E-feature and syntactic focus movement. Suppose that the remnant *Bill* is marked as being focused, i.e. F-marked, bearing the subscript F.

(1) John invited Mary and Jane did _ Bill.

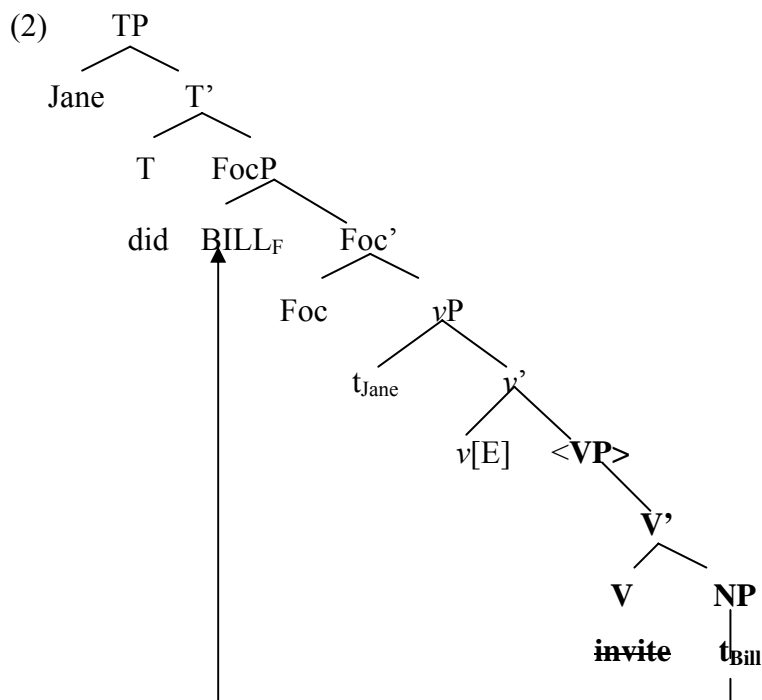

As this remnant is in the domain of the E-feature, which is placed on the Focus head of a Focus phrase above ν P (following Merchant 2006), the focused remnant has to move out of the VP, in order to make the deletion of the ν P go through. An alternative account to this, which still adapts Merchant's (2001) E-feature mechanism, but deletes the VP rather than the entire ν P, could consist of placing the E-feature on the ν head, thereby triggering the deletion of the complement of ν P, i.e. the VP. In the structure in (2), this latter option is illustrated (cf. also Gengel 2006a for a slightly different account, placing the E-feature on V).

The derivation of Pseudogapping proceeds thus in two steps: first, the focused remnant moves out of the VP. Then, the E-feature on the head ν triggers deletion of its complement, the VP.

Note that in this configuration, the verb must not move from V to ν , which can, however, be captured via the presence of the E-feature on ν , which prohibits the movement of the V to a position that hosts the E-feature. The bold-faced part of the structure is the VP that is elided after the remnant, *Bill_F*, has vacated the VP.

The same process can be assumed for the derivation of VP Ellipsis, as described in the next subsection.

9.2. VP Ellipsis

Since Pseudogapping is treated as VP Ellipsis with the remnant moving out of the VP prior to deletion, the VP Ellipsis construction can be described in a straightforward manner. Consider the VP Ellipsis example in (3), where the elided structure is indicated in (3b).

- (3) a. John invited Jane, and Mary did too.
b. John invited Jane, and Mary did <invite Jane> too.

The derivation proceeds as in the Pseudogapping case in (2), without movement of the object remnant. Again, the Voice head ν is marked with the E-feature, yielding the configuration in (4).

(4)

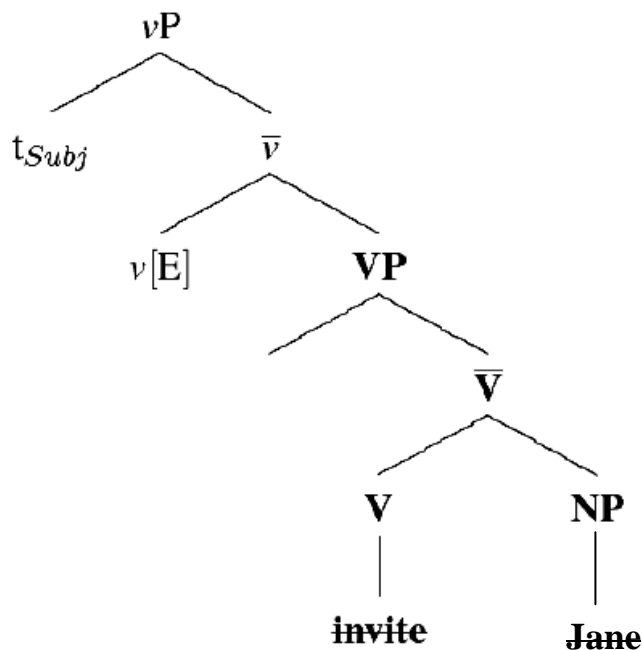

In contrast to Pseudogapping, the VP ellipsis remnant, *Jane*, is not contrastive, hence, the Focus feature is absent on the object, *Mary*, and no movement is triggered. Thus, the complement of the v head, the maximal projection VP, contains no focused material and can be deleted straightforwardly.

9.3. Voice Alternations in Ellipsis

Recall from the discussion in chapter 8 that Pseudogapping and VP Ellipsis seem to differ with respect to voice alternations. The relevant contrast is illustrated in (5) - (6) (VP Ellipsis) and (7) - (8) (Pseudogapping) below (examples taken from Merchant 2007, 2f., his (1) – (4)).

(5) The system can be used by anyone who wants to. <use it>

(6) Actually, I have implemented it [= a computer system] with a manager, but it doesn't have to be. <implemented with a manager>

(7) *Hundertwasser's ideas are respected by scholars more than most people do his actual work. <respect>

(8) *Laypeople respect Hundertwasser's actual work more than his ideas are by scholars. <respected>

Coppock (2001: 2, her (4c)) considers the following example in (9) to be marginal (as opposed to ungrammatical).

(9) ?That should be explained to individual students by the TA, but the professor will to the class in general.

This judgement is shared to some extent by Johnson (2003: 24), who gives the examples in (10) (*ibid.*, his (81a)) and (11) (his (82a)).

(10) ?The budget cuts might be defended publicly by the chancellor, but surely she wouldn't _ her labor policies.

(11) ?Sal may be a talented forger of passports, but surely he can't _ paintings.

Johnson (1996a: 94) notes, however, that the situation in VP Ellipsis is not entirely straightforward, since there seems to be a difference between passive antecedents which make good VP Ellipsis cases with an active elided phrase as in (12) (Johnson 1996a: 94, his (63)).

(12) a. This information could have been released by Gorbachev, but he chose not to.
b. A lot of this material can be presented in a fairly informal and accessible fashion, and often I do.

In contrast, active VPs seem to make less good antecedents, as shown in the contrast between (13a) and (13b) (Johnson 1996a: 95, with (13a) his (64), taken from Fiengo and May 1994).

(13) a. ?Max fired Harry, although it was Tom who should have been.
b. The arms were hidden by the rebels as a woman would (do) her most precious jewels.

It seems, then, that judgements are subtle and not conclusive for VP Ellipsis. Merchant (2007b: 21, fn. 2) thus concludes, also on the basis of the grammatical sentence given in (13b) above (quoted from Merchant 2007b: 21, fn. 2, originally from Miller 1994: 94, his (55)), that grammars which permit the Pseudogapping examples, not treating them as marginal or ungrammatical, may treat Pseudogapping and VP Ellipsis on a par, both as VP Ellipsis.

If, however, there is a clear difference, as there seems to be for some speakers, the reason for the unacceptability is, according to Merchant (2007a, 2007b), to be found in the different sizes of deletion: while VP Ellipsis targets VPs, Pseudogapping targets *v*P, including the Voice head, which must, therefore, be identical for Pseudogapping to be licensed (cf. also the discussion of verb raising in chapter 8, section 8.3.2.).

9.3.1. VP and *v*P as Targets of Deletion in Ellipsis and Pseudogapping

In Merchant's (2007a, b) account, VP Ellipsis, where voice mismatches are allowed, would thus receive a structure as in (15) below (Merchant 2007a: 7, his (6)), for the example in (14) (*ibid.*), where (15a) illustrates the structure of the antecedent, and (15b) shows the structure of the elided clause.¹⁴⁰

(14) This problem was to have been looked into, but nobody did.

Crucially, in these cases, the value of the voice head differs, which excludes it from deletion in general. In Merchant's terms (e.g. Merchant 2007a, b), the E-feature works such that it deletes the complement of the head it is attached to, and thus targets the VP in VP Ellipsis, since the E-feature is placed on *v* (or Voice, see Merchant 2007b for a slightly different implementation regarding this particular point).

¹⁴⁰ As the opposite case is almost equally straightforward, I will not discuss the example with an active antecedent and a passive ellipsis here, and refer the reader to Merchant (2007a, 2007b) for details concerning the derivation of those cases.

(15)

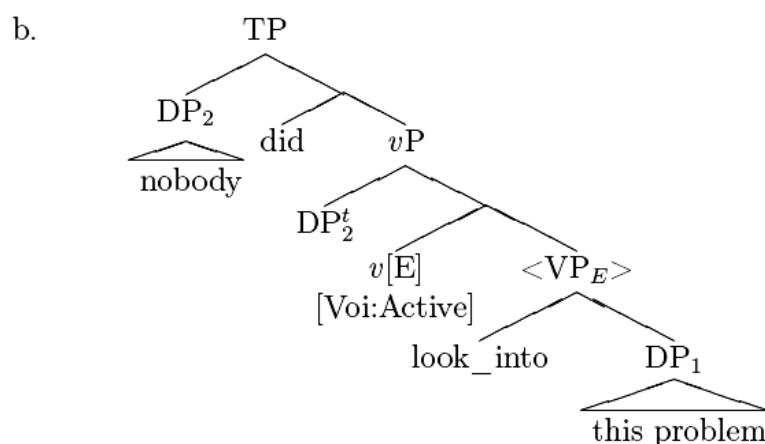
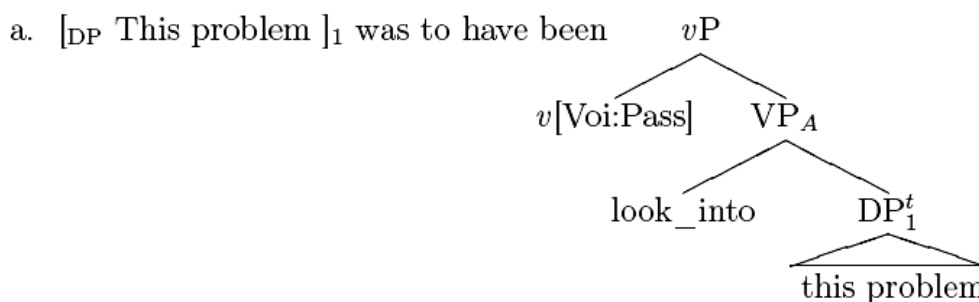

In Pseudogapping, on the other hand, Merchant (2007a, b), following Jayaseelan (2001) and Gengel (2006a) in assuming a Focus projection above *vP* (cf. the discussion of Merchant's (2007a) proposal in chapter 8, section 8.2.4.), contends that the E-feature is placed on the Focus head, which triggers deletion of the complement of the Focus projection, that is, deletion of the *vP*.¹⁴¹

¹⁴¹ Note, however, that on this assumption, it is not quite clear why certain speakers should allow voice mismatches in Pseudogapping. In the featural setting of the E-feature in Merchant's terms, it seems quite impossible to have an E-feature on a higher focus projection, which would target only the lower part of the *vP*, the *VP*, instead of the full *vP* complement. A workable solution to this problem might be provided in a phase-based approach to deletion with multiple specifiers, or in a structure as proposed in Jayaseelan (2001), where the Focus head functions as an outer specifier of *vP*. In the latter configuration, however, it is difficult to see how focus could be treated as the licensing element for Pseudogapping, if there is no separate head Focus in the structure. Moreover, the licensing conditions on *VP* Ellipsis and Pseudogapping would then be the same, which might not be in the spirit of Merchant's proposed analysis. As becomes obvious from this discussion, the consequences of this difference in speaker judgements are quite complex, which is why I will reserve a thorough investigation of this issue for future research.

In the sentence in (16), taken from Merchant (2007a: 11, his (9)), the structure of the antecedent of the ungrammatical Pseudogapping example in (16a) is given in (16b). (Note here that Merchant assumes a right adjunction of the passive *by*-phrase to the *v*P layer, and movement of the auxiliary from *v* to T.) What is crucial for our discussion is that the Voice head *v* is specified as being passive (marked *v* [Voi:Pass] in (16b)).

(16)

a. *Roses were brought by some, and others did lilies.

b.

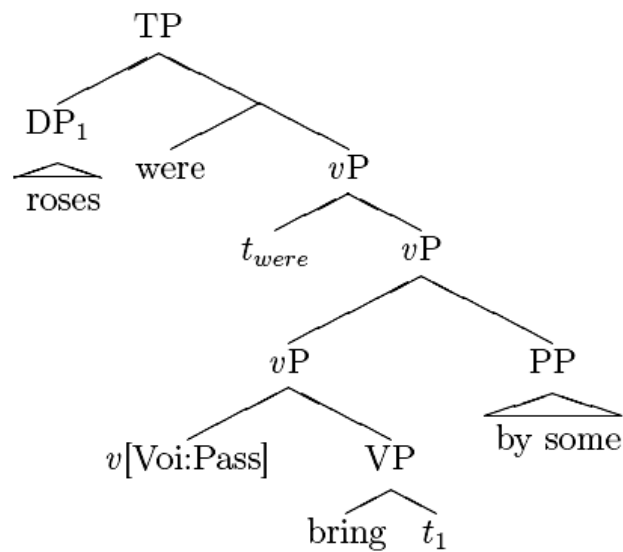

c.

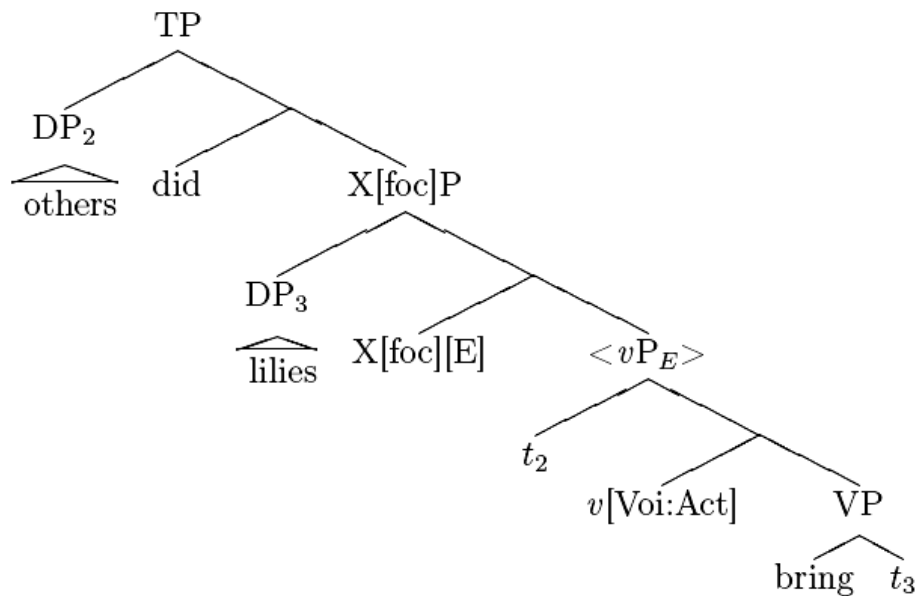

Given that in (16c), in the phrase containing the elided structure, *v* is specified as being active (marked as *v* [Voi:Act]). This difference in the feature specification of the two voice heads leads to the unacceptability of the Pseudogapping derivation in this case, since, as mentioned above, the E-feature on the Focus head triggers deletion of the *v*P, which is excluded if the material inside the *v*P is not identical to the material in the antecedent (irrespective of the presence of the *by*-phrase, cf. Merchant 2007a: 11).¹⁴²

While I am inclined to agree with Merchant's (2007a, b) analysis to account for this difference in speaker judgements (albeit with some reservations regarding the variety of possible judgements), I believe that an analysis that treats Pseudogapping and VP Ellipsis on a par, as suggested in chapter 8 with respect to the size of deletion, is still feasible.

Interestingly enough, the same conclusion was reached in Johnson's (2004) account of VP Ellipsis. However, in contrast to my analysis of Pseudogapping and VP Ellipsis both potentially involving VP Ellipsis, Johnson contends that VP Ellipsis involves *v*P deletion rather than VP deletion, thus arguing for the opposite solution. If this were true, then, again, Pseudogapping (as conceived in Merchant's (2007a, b) analysis) and VP Ellipsis can, again, be treated on a par with respect to the elided constituent. In what follows, I will briefly outline the two arguments Johnson provides for this claim that VP Ellipsis involves *v*P deletion.

9.3.2. *v*P (and not VP) as Target of Deletion in VP Ellipsis (Johnson 2004)

Johnson (2004) proposes an account of ellipsis in terms of phonological projections (*p-projections*). These projections are intended to implement the mapping between syntax and phonology.¹⁴³ This mapping includes focused constituents, and silent constituents.

If the focus projection maps phonological properties, that is, pitch accent, onto phrases, then, Johnson (2004: 5f.) contends, ellipsis can be conceived to be a similar process, in that it maps

¹⁴² Interestingly, this seems more like a focus identity requirement, rather than only mutual entailment (as in Merchant 2001) (Howard Lasnik, p.c.).

¹⁴³ More specifically, a focused constituent, for instance, is f-marked, where f-marked phrases are projections of pitch-accented words, in Johnson's approach (given that in English, focus is related to phonology via pitch accent). For the purposes of our discussion here, we will be more concerned with the syntax-phonology mapping of material that will be elided.

silence onto phrases. Thus, “[e]lided phrases... will be p-projections of words that have no phonetic content.” (Johnson 2004: 6).

As mentioned above, Johnson assumes that what is deleted in VP Ellipsis is actually the *vP*, and not the VP, as is illustrated in (17) (Johnson 2004: 6, his (21), with the subscript *e* indicating deletion).¹⁴⁴

(17) Jerry ate natto because

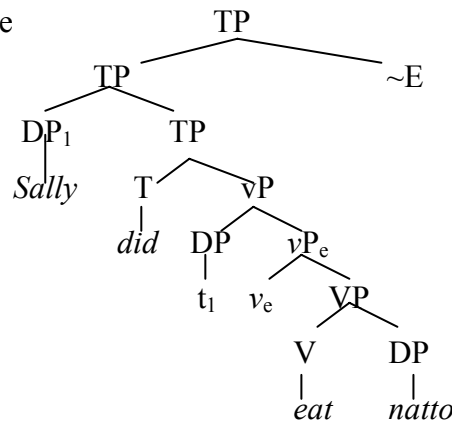

Crucially, the elided category is the *vP*, which is, in Johnson’s terms, “headed by a phonetically empty word” (Johnson 2004: 6). In support of this claim, Johnson adduces two arguments to show that VP Ellipsis targets the *vP* layer, the first one being, paradoxically enough, voice alternations, and the second, the status of *again* in VP Ellipsis contexts.

With respect to voice alternations, Johnson (2004: 7) compares the active/passive alternation with a transitive/unaccusative alternation. The examples in (18) and (19) illustrate the relevant alternation, which is then translated into the structures in (20) and (21), respectively (Johnson 2004: 7, his (22) and (23), going back to Sag (1976)).

(18) This can be frozen.

Please do <freeze this>.

(19) This can freeze.

* Please do <freeze this>.

¹⁴⁴ I will not go into details concerning the role of the ~E complex in the tree structure given above, as it does not bear directly on our discussion here. See Johnson (2004, 2005) for details regarding this particular implementation of deletion.

(20)

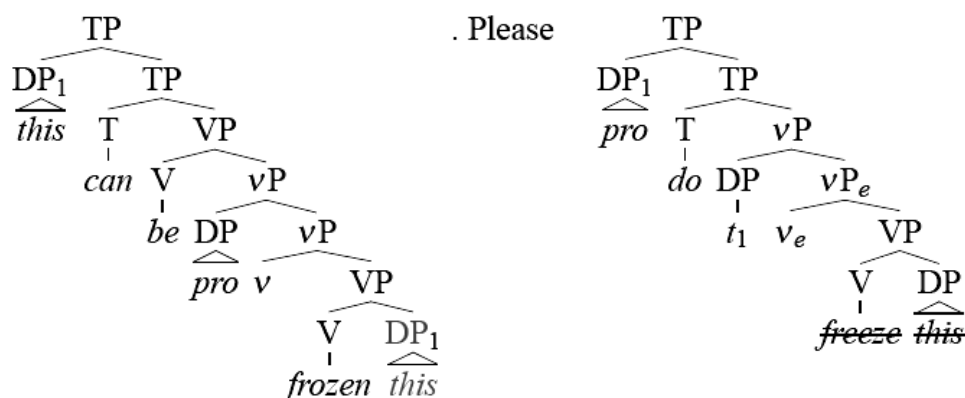

(21)

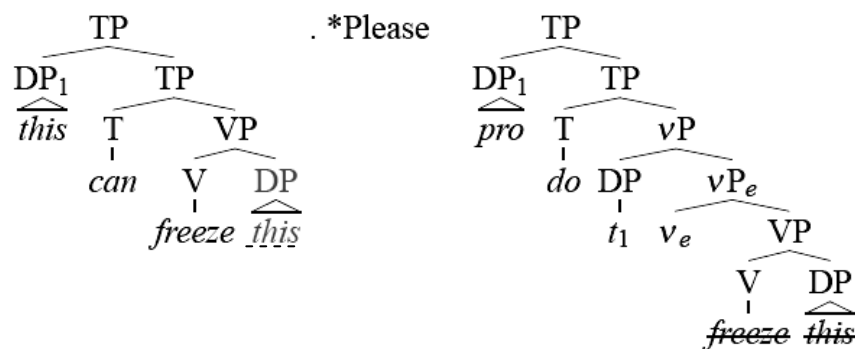

Note here that Johnson (2004: fn. 3) assumes that the passive involves an implicit agent ('*pro*' in the structures given above), and that movement involves copies (underlined in the tree structures in (20) and (21)).

In the structure with the grammatical outcome in (20), there is a *pro* present in the antecedent, that is, an implicit agent role is present. This, according to Johnson (2004: 7) allows us to assume that the agent θ -role is the same in both conjuncts, which is why the sentence is grammatical, as identity between the two structures is established. As Johnson puts it, "they both have vPs that meet the antecedence condition on ellipsis." (ibid.).¹⁴⁵

This agent θ -role is not present in both conjuncts in the transitive/unaccusative alternation, however, as can be seen in (21) above. On the assumption that an unaccusative sentence does

¹⁴⁵ Howard Lasnik (p.c.) points out that this is somewhat problematic since the understood subject is clearly 'you', whereas the explicit agent is arbitrary.

not have a ν P or lacks a specifier of ν P, the necessary identity between the clauses is not given, which renders deletion of the ν P in these cases ungrammatical.

Given the alternations outlined above, Johnson (2004: 7) conjectures that it is not the verb itself that is responsible for determining whether a VP can be elided under identity with the antecedent, but that it is rather a silent predicate which accounts for the distribution of ellipsis. As such, it is “necessarily part of the elided phrase” (Johnson 2004: 7).

This latter consequence, apparently a straightforward conclusion from Johnson’s (2004) account of p-projections, then amounts to another way of implementing the difference between the two voice heads in the antecedent and the elided clause. If there is an agent present in the antecedent, there is the possibility of ellipsis. If, as in the unaccusative case, no agent is present, ellipsis is ruled out.

While this accounts for the distinction between passive and unaccusative antecedents, it cannot account for the curious distinction between Pseudogapping and VP Ellipsis, since, if both Pseudogapping and VP Ellipsis involve ν P deletion, there should be no difference in the acceptability of voice mismatches, that is, both constructions should show the same effects, if ν P is included in the deletion in both cases.

The second argument for VP Ellipsis being conceived as ν P deletion rather than VP deletion in Johnson’s (2004) account stems from the status of ‘again’ in VP Ellipsis. As I have discussed the data in chapter 8 with respect to the size of deletion (cf. section 8.6. for discussion), I will not consider it here. However, the overall (in)conclusion from the section above is that if Johnson (2004) is correct in analysing VP Ellipsis as ν P Ellipsis, this creates a new perspective on the voice mismatches discussed above. On his approach, voice mismatches should only be able to go one way, a prediction that remains yet to be confirmed. I will thus conclude that pending further evidence with regard to the voice mismatches, the size of the deletion in both VP Ellipsis and Pseudogapping cannot be ultimately decided upon.

For the time being, then, I propose that we continue to treat Pseudogapping and VP Ellipsis on a par, both involving VP deletion, that is, in other words, non-Spell-out of the phasal domain.

9.4. Sluicing and Fragment Answers

If we move up from the VP domain to the CP level, we find that the analysis proposed above could also hold for those elliptical structures that involve deletion of more than the VP. Recall that in Sluicing, given in (22) below, Merchant (2001) assumed an E-feature on C, triggering deletion of the TP as a consequence. Thus, the movement and deletion strategy advocated above can be applied straightforwardly.

(22) Jack bought something, but I don't know what [~~Jack bought t~~].

Given that I suggested that the movement in Pseudogapping is focus movement, the question that arises in the context of a uniform treatment of ellipsis in English is whether the movement in Sluicing could also be treated as focus movement, rather than *wh*-movement, as assumed in Merchant (2001, 2004). Consider the structure in (23), where the bold-faced material is deleted.

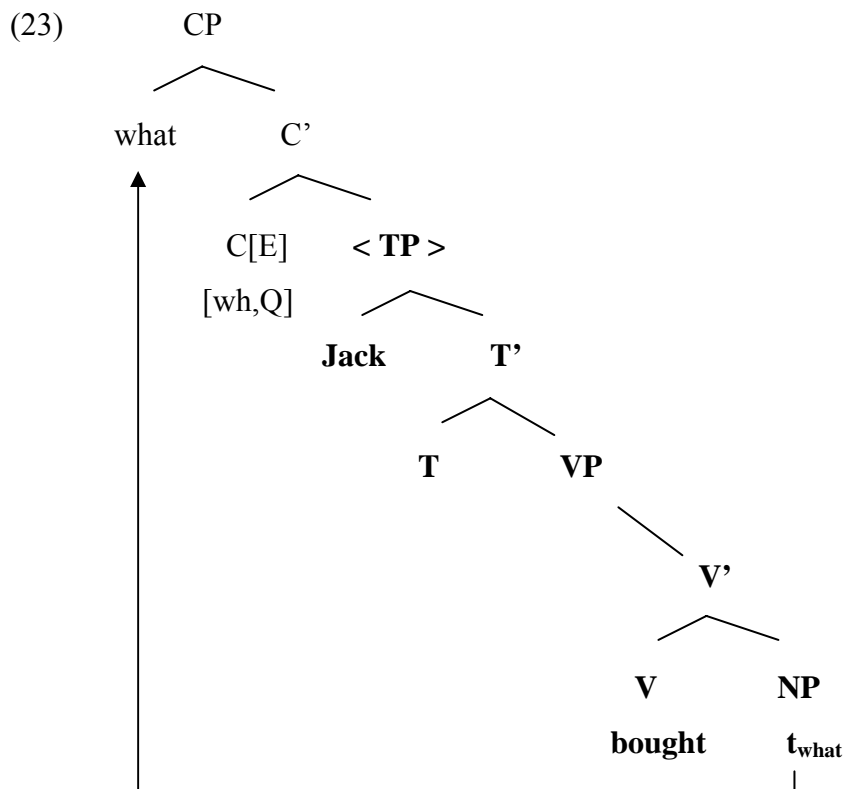

The Sluicing derivation in the terms proposed above hinges on two implicit, fundamental assumptions.

First of all, there should not be any focused material within the domain of the E-feature, that is, within the TP. This is borne out, as we can see in the examples in (24).¹⁴⁶

(24) a. *Jack bought something, but I don't know what SUSAN [~~bought t~~].

b. Jack bought something, but I don't know what Susan did/bought.

Here, the presence of focused material, the subject, would not result in Sluicing but rather in VP Ellipsis or a sentence with the verb repeated, as in (24b).

Secondly, for my proposal it is essential that the remnant moved out of the complement position in Sluicing be contrastively focused. Only then would it be possible to postulate that the movement up to the specifier of CP could be due to focus (even if it took the guise of regular *wh*-movement). The link to focus, however, is already given in Merchant's (2001) analysis of E-Givenness in Sluicing.

Recall that Merchant (2001, and subsequent work) based his definition of the E-feature on the notion of E-Givenness, here repeated as (25).

(25) E-Givenness:

An expression E counts as e-GIVEN iff E has a salient antecedent A and,
modulo \exists -type shifting,

(i) A entails F-clo(E), and

(ii) E entails F-clo(A).

In its application, the concept of E-Givenness involves the computation of appropriate alternatives, to derive the F-closures of the relevant parts of the structure (see chapter 7 for detailed discussion).

In Sluicing, then, the question is how to define alternatives to questions, which will be the basis for the decision of what is considered to be Given. To this end, Merchant uses

¹⁴⁶ Howard Lasnik (p.c.) points out (24a) is also ungrammatical without focus, as illustrated in (i) below.

(i) *Jack bought something but I don't know what he.

One way to capture the example in (24) is by invoking the *MaxElide* principle.

Romero's (1998) analysis. The general idea in Romero (1998; as paraphrased in Merchant (2001: 29f.)), is to treat the questions in (26) (Merchant 2001: 30, his (53)) as being alternatives of one another.

- (26) a (know) which P are Q
b (know) how many P are Q
c (know) whether any P are Q

For a sentence such as (27) (Merchant 2001: 30, his (56)), then, the alternatives can be defined as in (28) (Merchant 2001: 30, his (57)).

(27) I know how MANY politicians she called an idiot, but I don't know WHICH (politicians).

- (28) a. (know) which politicians she called an idiot
b. (know) how many politicians she called an idiot
c. (know) whether she called any politicians an idiot

Merchant (2001: 30) contends that replacing the F-marked material in (27) yields (29) (Merchant 2001: 31, his (58)), with Q being the variable over *wh*-determiners.

(29) $\exists Q$ [I know [Q-politicians she called an idiot]]

On the basis of these computations, Merchant (2001: 31) concludes that the correct Sluicing configuration can be derived, since, as he puts it, the knowledge that the person in the example called a politician an idiot makes this knowledge given information.¹⁴⁷

While I refer the reader for a more detailed discussion of these examples to the discussion in Merchant (2001: 32ff.), it is clear from the argumentation above that Merchant (2001) necessarily treats the *wh*-element in Sluicing as being focused. This hypothesis is often

¹⁴⁷ Merchant notes (2001: 30, fn. 15) that the same result can be reached on the basis of Rooth's account, in assuming that the focus value of E, i.e. $\|\text{WHICH}_F(\text{politicians}) \text{ she called an idiot}\|^f$ is the set of alternatives {which politicians she called an idiot, how many politicians she called an idiot, whether she called any politician an idiot}. A, in turn, would be defined as "how many politicians she called an idiot", which yields the correct result that $A \in E^f$.

maintained in the literature, for instance, in Rizzi's (1997) account of the left periphery, where it is suggested that the movement of the *wh*-element takes the specifier of a Focus Phrase in the CP as its landing site.

A further argument for the claim that *wh*-movement in Sluicing might be due to Focus comes from a parallel that Merchant (2004) suggests exists between cases of Sluicing and Fragments. Recall from the discussion in previous sections of this chapter that the derivation of Sluicing was taken to be due to a [+*wh*, +Q] feature specification, thus moving the sluiced element to a *wh*-position, [Spec,CP]. According to Merchant (2004), the feature specification for Fragments would be [+Foc], thus yielding the [Spec,FocP] in the CP domain as the final landing site for the moved item (cf. Merchant 2004: 675, and the first part of this chapter for discussion). He thus concludes that "the derivation [of Fragments] is parallel to that of sluicing, modulo the difference in the moved item, its landing site, and the featural requirements of the E_f [the E-feature for Fragments] trigger." (Merchant 2004: 675).

Thus, at this point, if it were not for peculiarities that arise with island effects in the two structures (cf. the discussion in section 9.5. below), once we adopt Rizzi's (1997) claim that *wh*-elements target the Focus Phrase, Sluicing and Fragments could indeed have the same derivation, that is, both could focus-driven movement, as illustrated in (31) below for the derivation of the Fragment example in (30) (Merchant 2004: 673, his (37)).

- (30) a. Who did she see?
 b. John.
 c. She saw John.

(31)

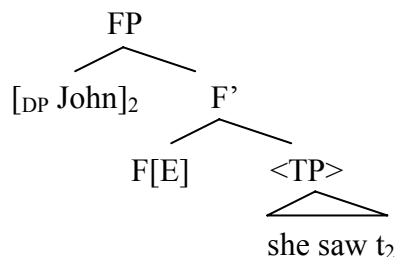

An issue that is connected to the derivation of ellipsis in the higher domain of the sentence, as opposed to deletion in the lower domain, that is, the VP, is the question of island effects in ellipsis, which I will describe in the next section, in view of their impact on focus movement in particular.

9.5. Island Effects in Ellipsis

According to Merchant (to appear), one important distinction between ellipsis in the higher domain of the clause, such as Sluicing, and ellipsis in the lower domain of the clause, that is, VP Ellipsis, consists in their respective sensitivity to islands.¹⁴⁸ This runs counter to Lasnik’s assumption (proposed in Lasnik 1999c, Fox and Lasnik 2003, among others) that the badness of VP Ellipsis has nothing to do with (classic) islands. As we will see below, the status of VP Ellipsis in this respect is indeed controversial. However, since focus seems to interact with islands, I will discuss some issues related to islands in what follows.

On the basis of the observations in Merchant (to appear), the following picture emerges (32) if we compare Sluicing and VP Ellipsis with respect to their grammaticality if there are islands present in the structure (marked with ✓ as grammatical, and * as unacceptable).

Interestingly, as shown in (32), there is a difference with respect to island sensitivity once focus is present in the structure as well. I will give first the summary, that is, the table in (32), and then proceed to discuss the relevant examples illustrating the point.

(32)

	Sluicing	VP Ellipsis
no Focus	✓ island-containing	* island-containing
	✓ non-island-containing	* non-island-containing
Focus	* island-containing	* island-containing
	✓ non-island-containing	✓ non-island-containing

¹⁴⁸ Cf. also the discussion of repair by ellipsis in chapter 8.

The relevant examples are as follows in (33) to (41) for Sluicing (taken from Merchant to appear: 4f., his (8) to (16)).

(33) *Relative clause island:*

- a. They want to hire someone who speaks a Balkan language, but I don't remember which.
- b. * I don't remember which (*Balkan language*) they want to hire someone [*who speaks* ___].

(34) *Left-branch* (attributive adjective case):

- a. She bought a big car, but I don't know how big.
- b. * I don't know how big *she bought* [*a* ___ *car*].

(35) *Derived position islands* (*subjects, topicalizations*)

- a. A biography of one of the Marx brothers is going to be published this year — guess which!
- b. * Guess which (*Marx brother*) [*a biography of* ___] *is going to be published this year*.

(36) *COMP-trace effects:* (cf. Chung et al's 1995 (90), (91a), Perlmutter 1971:112)

- a. It appears that someone will resign, but it's not yet clear who.
- b. Sally asked if somebody was going to fail Syntax One, but I can't remember who.

(37) *Coordinate Structure Constraint:*

- a. They persuaded Kennedy and some other Senator to jointly sponsor the legislation, but I can't remember which one. (Chung et al's 1995 (88b))
- b. Bob ate dinner and saw a movie that night, but he didn't say which.

(38) *Adjuncts:*

- a. Ben will be mad if Abby talks to one of the teachers, but she couldn't remember which.
- b. * Ben will be mad if Abby talks to one of the teachers, but she couldn't remember which (*of the teachers*) *Ben will be mad* [*if she talks to* ___].

(39) *Complement to nouns*: (Chung et al's 1995 (84c))

The administration has issued a statement that it is willing to meet with one of the student groups, but I'm not sure which one.

(40) *Sentential subject*: (Chung et al's 1995 (84b))

That certain countries would vote against the resolution has been widely reported, but I'm not sure which ones.

(41) *Embedded question*: (Chung et al's 1995 (84a))

Sandy was trying to work out which students would be able to solve a certain problem, but she wouldn't tell us which one.

In each of these examples, the potential island violation is remedied by Sluicing. Thus, in this sense, ellipsis can be viewed in terms of a repair strategy (although this is not Merchant's line or argument for all examples; on the repair strategy see chapter 8, section 8.8. for discussion).¹⁴⁹

However, if focus movement is involved, as in the examples given (42) (Merchant to appear: 14, his (52)), the island violations persist.

- (42) a. *Abby wants to hire someone who speaks GREEK, but I don't remember what OTHER languages <she wants to hire someone who speaks>.
b. *The radio played a song that RINGO wrote, but I don't know who else.

It seems, then, that Sluicing with focussed correlates fails to repair island violations (cf. Merchant to appear: 14).

For VP Ellipsis, the picture is somewhat different. The examples in (43) to (50) (taken from Merchant to appear: 6f., his (18) to (25)) show that the island violations persist despite the deletion process.

¹⁴⁹ Thanks to Howard Lasnik (p.c.) for valuable comments on this matter.

(43) *Relative clause island:*

*They want to hire someone who speaks a Balkan language, but I don't remember which they do.

(44) *Left-branch* (attributive adjective case):

*She bought a big car, but I don't know how big she did.

(45) *Derived position islands* (subjects, topicalizations)

*He said that a biography of one of the Marx brothers is going to be published this year — guess which he did!

(46) *COMP-trace effects:*

- a. *It appears that someone will resign; it's just not clear yet who it does.
- b. *Sally asked if somebody was going to fail Syntax One, but I can't remember who she did.

(47) *Coordinate Structure Constraint:*

- a. *They persuaded Kennedy and some other Senator to jointly sponsor the legislation, but I can't remember which one they did.
- b. *Bob ate dinner and saw a movie that night, but he didn't say which he did.

(48) *Adjuncts:*

*Ben will be mad if Abby talks to one of the teachers, but she couldn't remember which he will.

(49) *Complement to nouns:*

*The administration has issued a statement that it is willing to meet with one of the student groups, but I'm not sure which one it has.

(50) *Embedded question:*

*Sandy was trying to work out which students would be able to solve a certain problem, but she wouldn't tell us which one she was.

The consistent ungrammaticality of the VP Ellipsis cases may, at first glance, be due to the observation that *wh*-extraction out of VP Ellipsis is problematic anyhow, even if no island violations are created. This is shown in the examples in (51) and (52) (Merchant to appear: 7, his (26) and (27), attributed to Lasnik (2001b)).

- (51) They said they heard about a Balkan language, but I don't know
- | | |
|--------------------------------------|-------------|
| a. which they said they heard about. | NO ELLIPSIS |
| b. which. | SLUICING |
| c. *which they did. | VP-ELLIPSIS |
- (52) They attended a lecture on a Balkan language, but I don't know
- | | |
|---|-------------|
| a. which they attended a lecture about. | NO ELLIPSIS |
| b. which. | SLUICING |
| c. *which they did. | VP-ELLIPSIS |

However, there are data of VP Ellipsis where extraction seems to be allowed, as illustrated in (53) (Merchant to appear: 7, his (29b), (30a,b), (31c,e,g)). This, in fact, is predicted on the basis of Fox and Lasnik's (2003) analysis.

- (53) a. I know which books she READ, and which she DIDN'T.
 b. GREEK, you should take; DUTCH, you shouldn't.
 c. I know which books ABBY read, and which ones BEN did.
 d. ABBY took GREEK, but I don't know what language BEN did.
 e. (I know) ABBY wants to take GREEK, but I don't know what language BEN does
 <want to take>.
 g. ABBY attended a lecture on KEATS, but I don't know what poet BEN did.

The contrast to the examples given above is clear: extraction seems to be allowed once there is focus present in the structure. The focus movement, however, while it licenses movement in contexts without islands, still blocks sentences where islands are contained in the structure,

as indicated in table (32) above, and illustrated in the examples in (54) below (Merchant to appear: 14, his (53b)).¹⁵⁰

- (54) a. *Abby DOES want to hire someone who speaks GREEK, but I don't remember what kind of language she DOESN'T.
b. *BEN will be mad if Abby talks to Mr. RYBERG, and guess who CHUCK will.
(Merchant 2001:115 (15))

From these data, the conclusion to be drawn is that movement out of the VP Ellipsis site, whether it be *wh*-movement or focus movement, is not permitted if it would cause islands to be present in the structure.

The obvious questions that arise from this overview are the following.

- (i) Why should there be a crucial difference between Sluicing and VP Ellipsis with respect to island sensitivity?
(ii) Why should there be a difference once focus movement is involved?

The question in (i) has received much attention in the literature (see, for instance, Fox and Lasnik 2001, Merchant to appear, Merchant 2004, among many others), and I have nothing much to add to the theoretical debate in this respect.

As I have also no clear understanding of why focus movement is possible from VP Ellipsis sites, and, by extension, possible in Pseudogapping, as argued for in this dissertation, unless it results in island violations. I hope to be able to find an answer to this puzzle in future research. For the time being I will thus concentrate on the question in (ii), and consider the relation between focus and island-sensitivity.

Recall from the data in (42) and (54) above (here repeated as (55) and (56)) that focus movement in island contexts cannot be remedied by ellipsis, neither in VP Ellipsis (56), nor in Sluicing (55).

¹⁵⁰ Compare (54) above for the respective Sluicing examples, and Merchant (to appear: 10) for a variety of examples illustrating the whole range of island effects in VP Ellipsis (his (39) to (46)). Due to their overall similarity to the examples I gave in (43) to (50) above, I omit these examples for expository reasons.

- (55) a. *Abby wants to hire someone who speaks GREEK, but I don't remember what OTHER languages <she wants to hire someone who speaks>.
 b. *The radio played a song that RINGO wrote, but I don't know who else.

- (56) a. *Abby DOES want to hire someone who speaks GREEK, but I don't remember what kind of language she DOESN'T.
 b. *BEN will be mad if Abby talks to Mr. RYBERG, and guess who CHUCK will.

While VP Ellipsis with island violations is thus uniformly ruled out, the question arises why we find grammatical Sluicing with island violations, and ungrammatical Sluicing with the same island variations, as illustrated in the contrast between (57) and (58) (Merchant to appear: 4, his (8)).

- (57) *Abby wants to hire someone who speaks GREEK, but I don't remember what OTHER languages <she wants to hire someone who speaks>.

- (58) They want to hire someone who speaks a Balkan language, but I don't remember which <(Balkan language) they want to hire someone [who speaks __]>.

The answer to this problem might be found in the specific mechanism involved for the derivation of Sluicing.

Recall that Merchant (2001) proposed that the E-feature triggering Sluicing interacts with a [+wh,+Q] feature in C. The resulting movement in Sluicing is thus arguably regular *wh*-movement. His hypothesis, as becomes clear from the data above, can descriptively cover all the instances where no island violations occur, since Focus movement uniformly respects the island conditions.¹⁵¹

¹⁵¹ This statement is not entirely correct. If one assumes focus movement at the LF level, to establish the appropriate scope relations, this movement does not seem to obey the island constraints at all (cf. Kratzer 1991). This apparent contradiction is solved, however, if one assumes with Merchant (to appear: 15) that islands have an impact at the PF level. Thus, since the focus movement at the LF level does not create a different PF structure, the island conditions need not be obeyed in this instance.

On the other hand, it seems that Focus also plays a role in the derivation of Sluicing, since *wh*-elements can be treated as inherently focused. This would pattern with the analysis I put forward in this dissertation, but would, in turn, fail to account for why Sluicing quite abundantly obviates island effects.

Merchant (to appear: 15) suggests that in the focus movement case, the moved element is limited to the VP level, it cannot move up to the highest clause node. This stipulation prevents the necessary parallelism of scope. For deletion to go through in (59) below, repeated from (57), the focus-moved element in the antecedent and the focused element moved out of the elided clause should have the same scope.

(59) *Abby wants to hire someone who speaks GREEK, but I don't remember what OTHER languages <she wants to hire someone who speaks>.

In (60) (Merchant to appear: 16, his (56)), the scopal configuration of the antecedent is illustrated. In (61) (based on Merchant's (59), *ibid.*), the hypothesis that focus movement only moves elements to the VP if there is an island in the structure, is incorporated, and this particular configuration thus results in the clash between the two scope configurations of the antecedent and the elided clause.

(60) GREEK_F λ_x [_{IP} Abby [_{VP} x λ_x' [speaks x']]]

(61) [_{IP} Abby [_{VP} *what OTHER languages_F λ_x [_{VP} wants to hire someone who speaks x]]]

Hence, Merchant (to appear: 16) concludes that the scopal elements are not in a parallel position in the clause, and consequently prohibit both VP and IP deletion.¹⁵²

¹⁵² A discussion of whether this analysis of focus movement extends to the treatment of Fragment answers in Merchant (2004) is, unfortunately, beyond the scope of the present discussion. Note that in Fragments, the island constraints are consistently respected by focus movement, as shown in the ungrammaticality of the sentences in *Again*, island violations occur, as illustrated in (i) to (iv) (from Merchant 2004: 688f., his (87) to (90)).

(i) a. Does Abby speak the same Balkan language that *Ben* speaks?
 b. *No, *Charlie*.

While this presumption seems descriptively adequate, the question remains why there should be two kinds of movement in the derivation of Sluicing, since, as shown in the table in (32), both focused and non-focused elements are grammatical in non-island-containing contexts. In this respect, Kim's (1997) account of Sluicing might shed some light on this problem.

If Sluicing is, to some extent, dependent on focus, Kim's hypothesis (Kim 1997: 139) that Sluicing in English is restricted to interrogative clauses is plausible once we assume (as he does) that interrogative *wh*-elements in English are inherently focused. This patterns with the computation of alternatives that we have seen in Merchant's (2001) Sluicing account, with the derivation of the E-Givenness condition for Sluicing (cf. the discussion in chapter 8).

Accordingly, Kim (1997: 139) suggests that these interrogative *wh*-words bear both the [+*wh*] and the [+*focus*] feature. Sluicing, in his analysis (Kim 1997: 140) thus involves checking both the *wh*-feature and the focus feature. He further assumes that the focus feature is either generated in a separate focus head or in C (Kim 1997: 143). The important consequence of this claim, which also unifies Merchant's (2001) and my own analysis, is that focus is not necessarily checked in a focus projection.¹⁵³

In principle, then, movement can be triggered by different requirements which are satisfied in the same position.^{154,155} This basic assumption thus could explain the contrast between *wh*-movement and focus movement in Sluicing, and might turn out to be a feasible way to describe the focus movement effects without having to take recourse to a restriction on the relative length of movement, as in Merchant's (to appear) analysis. A more detailed investigation of this hypothesis, however, will have to await future research.

-
- (ii) a. Did Ben leave the party because Abby wouldn't dance with him?
b. *No, *Beth*.

- (iii) a. Did Abby vote for a Green Party candidate?
b. *No, *Reform Party*.

- (iv) a. Did Abby get '*The Cat in the Hat*' and '*Goodnight Gorilla*' for her nephew for his birthday?
b. *No, '*The Lorax*'.

¹⁵³ With regard to Pseudogapping, this claim could be implemented with the assumption of multiple specifiers of *vP*, for instance.

¹⁵⁴ Thanks to Jane Grimshaw for extremely helpful discussion of this point.

¹⁵⁵ Note, however, that there may be contexts in which both *wh*-movement and focus movement may be assumed, for instance, in multiple Sluicing contexts (see van Craenenbroeck and Lipták 2006, among others, for an approach along these lines).

9.6. Gapping

Accounts of Gapping largely treat Gapping as non-deletion, or, if there is deletion, it is not considered to be constituent deletion (e.g. Johnson's 1996 ATB-account, or Agbayani & Zoerner's 2004 sideways movement account). Combining the E-feature with a Focus feature allows us to reconsider gapping as ellipsis.

More specifically, I propose that Gapping is TP deletion. As such, the Gapping derivation can be included in the group of ellipsis structures that involve deletion of the TP layer, namely, Sluicing and Fragments. Moreover, the movement and deletion approach outlined above gives a principled explanation for the need of a contrastive subject in Gapping, an observation illustrated in the examples in (62).^{156,157}

- (62) a. Claire read a book, and Heather a magazine.
b. *Claire_i read a book, and she_i a magazine.
c. Claire_i read a book, and SHE_k a magazine.

In (62b), the subjects of the two conjuncts are co-indexed, which leads to ungrammaticality. This can be remedied if the two subjects are not co-indexed, as in (62c) with the stressed pronoun.

The gapping derivation I propose builds on the assumption that gapping involves a *contrastive topic – contrastive focus* structure (as put forward in e.g. Gergel et al. 2007). To accommodate for this focus structure, I follow Rizzi (1997) in general, and van Craenenbroeck (2004) for ellipsis cases in particular, and assume that a split-CP structure is necessary for the derivation of Gapping.

Applying the structure that Rizzi (1997: 288) proposed for the left periphery, illustrated in (63), we can assume that the subject and the object target positions in the extended C domain, namely, the Topic position and the Focus position.¹⁵⁸

¹⁵⁶ Cf. e.g. Lechner (2004: 112, fn. 103), a.o., on disjoint reference in Gapping.

¹⁵⁷ Incidentally, Pseudogapping differs in that respect. Levin (1986) points out that there is a very strong preference for coreferential subjects in Pseudogapping.

¹⁵⁸ As ForceP and FinP are not crucial to my purposes here, I will henceforth only consider the TopP/FocP projections.

As for the E-feature, I suggest that in Gapping, it applies at the TP level, thus being placed on the complementiser, or, rather, the conjunction, to delete the TP as a complement.¹⁵⁹ Forcing a strict parallel to the Sluicing and Gapping cases, we could alternatively assume that the E-feature be placed on the Focus head above the TP layer, thus triggering deletion of its complement, TP, similar to the Focus licensing fragment answers, and, of course, Pseudogapping on the VP level.¹⁶⁰

While the object can be considered to undergo long A-bar movement to the specifier of the Focus Phrase, much like regular *wh*-movement, the question is why the subject should be moved out of the TP.

Consider the derivation of the sentence in (64) at the TP level, as illustrated in (65).

(64) Claire read a book, and Heather a magazine.

(65) *TP level*

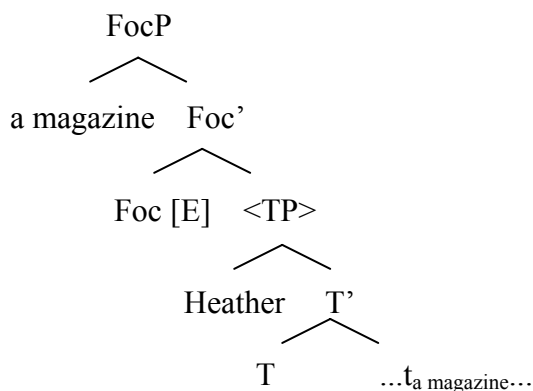

¹⁵⁹ With respect to the conjunction, I will remain agnostic as to how a conjunction phrase could be implemented. I will not be concerned with this issue here, and refer the reader to recent approaches to conjunction that I am familiar with for a small variety of possible implementations, such as Johnson's (2003) gapping account, and Moltmann's (1992), or te Velde's (2003) analysis of conjunction, to only give a few (rather syntax-oriented) examples.

¹⁶⁰ Alternatively, the relevant features could be checked with the E-feature in situ, so to speak, as suggested in Gengel (2006a, and subsequent papers), thus, the E-feature could be placed on the head T, triggering deletion of the maximal projection TP.

In the configuration in (65), the subject in [Spec,TP] is in the domain of the E-feature, hence, has to move out. Note that if the subject is not contrastively focused, it is not required to move out of TP, according to the proposal of focus-driven movement out of the domain of the E-feature that I suggested above.

Leaving a non-contrastive subject in situ would not cause problems for the overall derivation of the sentence, since then, bare argument ellipsis (stripping) could be derived, as in (66), provided that one assumes that in this construction, ellipsis has taken place.¹⁶¹

(66) Claire read a book, and a magazine.

If the subject is focused, however, permitting a contrastive topic interpretation, it has to vacate the TP in (65), and will move up to the specifier of the Topic Phrase above the Focus Phrase. To preserve the surface word order, I assume that the subject and object move in parallel fashion, thus not interfering with respect to their final landing sites. Moreover, as the subject moves up to [Spec,TP] in the usual fashion, via A-movement, subject movement and object movement do not interfere.

On the basis of the assumptions made above, I conclude that the particular information structure (i.e. contrastive topic - contrastive focus) of Gapping could be implemented via features. I suggest that in Gapping (in contrast to both VP ellipsis and Pseudogapping where the subject can be coreferential), the subject bears a (contrastive) topic feature, which triggers movement up to the Topic position in the C-domain, as illustrated in the structure in (67).

¹⁶¹ I am aware of the fact that there are different positions in the literature, and have no strong views concerning either approach, that is, on the question whether deletion is involved or whether the structure in (66) represents a mere constituent coordination. The point I wish to make here is that the structural configuration as in (67) would actually allow a derivation involving ellipsis in these cases.

(67) *CP level*

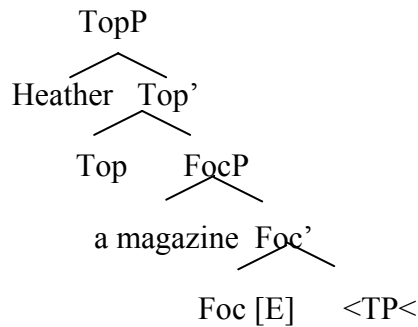

Assuming that the featural layout proposed above is correct, this would account for the general contrastivity of the subject in Gapping, and the non-coreferential reading if the subject pronoun is focused, as in (68) below (repeated from (62c) above, with the capitals indicating the contrastive topic).

(68) Claire_i read a book, and SHE_k a magazine.

The derivation of the Gapping sentence in (69) would then look as in (70) below.¹⁶²

(69) Claire read a book, and Heather a magazine.

¹⁶² In the structure in (70), I leave out the subject trace in the *vP* for expository reasons. Moreover, depending on the theoretical framework adopted, the object may have to move to an outer specifier of the *vP*, to leave the *vP* phase (in Chomsky's 2001, 2005 terms). As this is not crucial for our purposes, since object movement from this outer specifier position would still be A-bar movement, unlike the subject movement, I refrain from a detailed structure of the *vP* in (70).

(70)

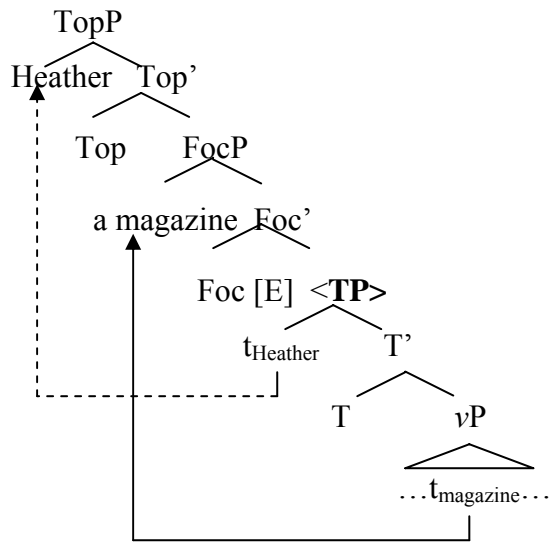

There is one problem with this type of analysis for Gapping, however. As Johnson (2000, a.o.) points out, the coordination in Gapping sentences seems to be on a lower level than the sentential level. Consider the examples in (71) and (72) (Johnson 2000: 95, his (2b) and (2d)).

(71) No boy₁ joined the navy and his₁ mother ~~joined~~ the army.

(72) *No boy₁ joined the navy and his₁ mother headed the army.

In cases such as (71), the scope of the quantificational element in the antecedent subject scopes over the second conjunct. In (72), in contrast, the element *his₁* of the second clause, which should be parallel to the one in (71), cannot be bound by the antecedent in the non-gapped version of the clause.

This discrepancy in scope also extends to other cases apart from negation, as illustrated below (73) (Johnson 2000: 104, his (18f)) with an *or*-conjunction, and *few* in the subject position.

(73) Few cats eat Frolic or ~~few~~ dogs ~~eat~~ Whiskas.

The non-gapped version is ungrammatical if the determiner is dropped, as shown in (74) (Johnson 2000: 105, his (19f)).

(74) *Few cats eat Frolic or dogs eat Whiskas.

Curiously, there are interpretational differences between the Gapping example in (73), here paraphrased as (75) (Johnson 2000: 105, his (21b)), and the non-Gapping counterpart, given in (76) (Johnson 2000: 105, his (20b)).

(75) It's not the case that many cats eat Frolic or many dogs eat Whiskas.

(76) Few cats eat Frolic or few dogs eat Whiskas.

In (76), the sentence is considered to be true if only one of the conjuncts is true. In (73), however, the Gapping example, where both conjuncts must be true for the entire sentence to be true, that is, if it is the case that many cats eat Frolic, the sentence (in its paraphrase in (75)) would be wrong.

Johnson (2000: 102) thus suggests that the coordinated structures have to be quite small in Gapping. He proposes that the cases described above (and Gapping, in general) should be derived via across-the-board movement (ATB), of the verb, and of other material that might also be across-the-board moved. Thus, the correct scope of the example with the negation in (71) above can be derived, if one assumes the structure in (77) below (Johnson 2000: 97, his (6)).

The derivation of (77) proceeds as follows. The verb is ATB-moved out of each of the VPs.

Note that Johnson (2000: 96) assumes overt main verb raising in English, coupled with the hypothesis that main verbs move to the head of TP, with the auxiliary moving up to the Agr position (Johnson 2000: 96f., and fn. 3). Except for the treatment of the auxiliary, for which I do not assume movement, as we will see below, these specific features of Johnson's account are immaterial for our purposes here.

To obtain the correct surface order of the two subjects, Johnson (2000: 96) suggests that the subject of the first conjunct is moved to the higher subject position, while the subject of the second conjunct remains in its underlying position.

Thus, the scope of *no boy* in the example in (71) is accounted for, since it has scope over both conjuncts in the structure given in (77).

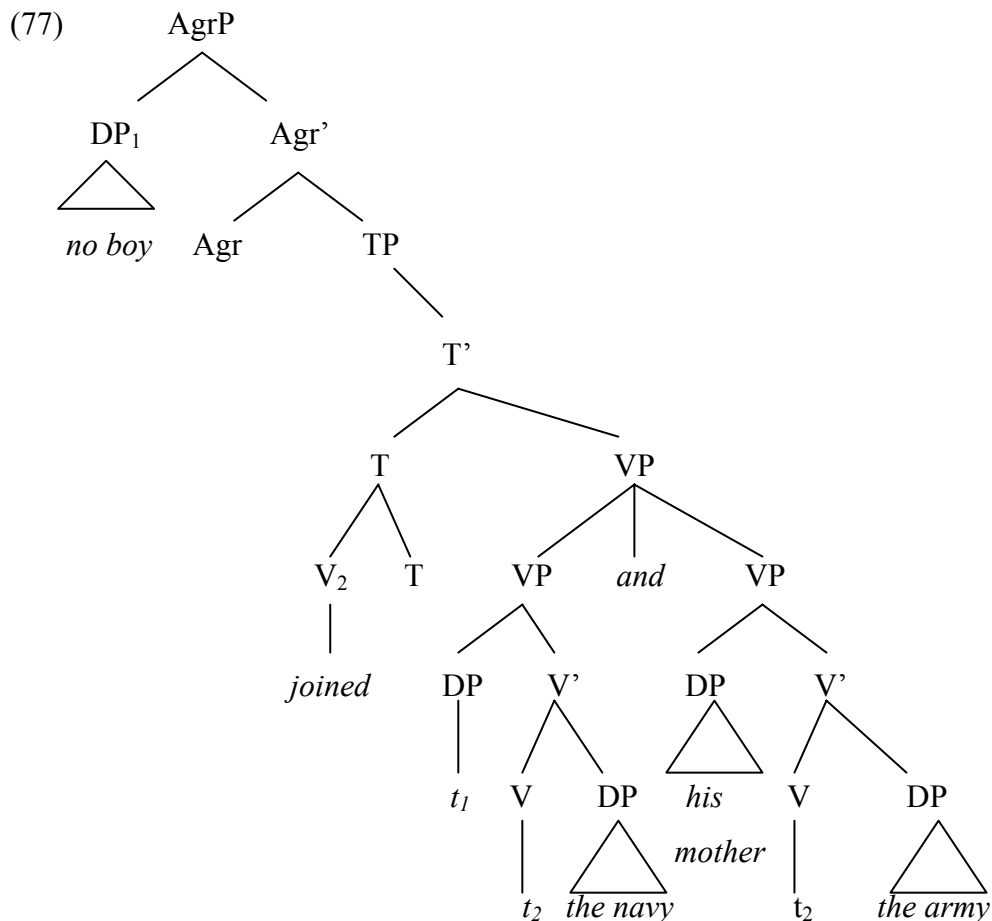

With quantifiers, the derivation is slightly more complex. For the sentence in (73), here repeated as (78), Johnson (2000: 108) assumes that there is a separate quantifier phrase, QP, which hosts *few*, as illustrated in (79) below (Johnson 2000: 108, his (24a)).

(78) Few cats eat Frolic or few dogs eat Whiskas.

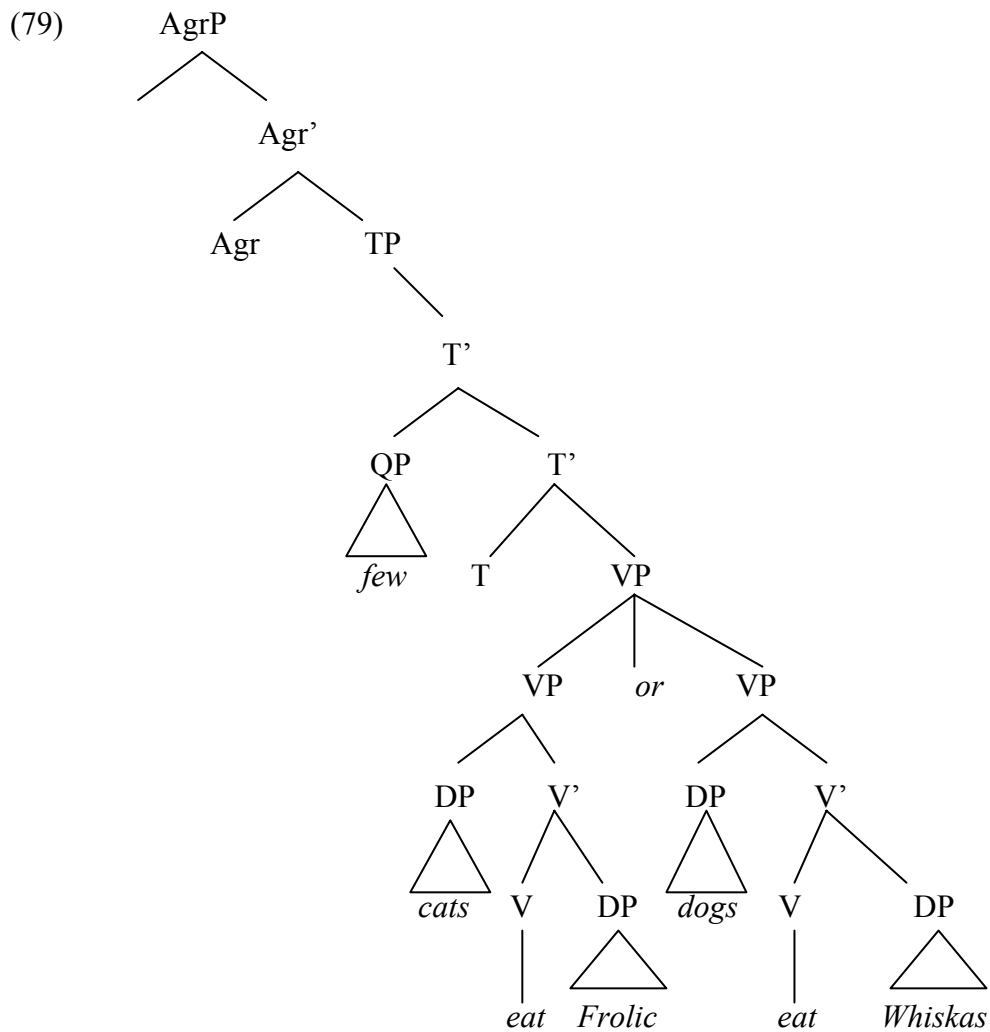

In (80) below, the next step of the derivation, the verb moves up to T via across-the-board movement out of the two conjuncts. In a second step (though the order may be irrelevant), the subject of the first conjunct, the DP *cats* moves up into the quantifier phrase QP.

Finally, the whole complex inside the QP is then moved up into the specifier position of Agr, which correctly derives the scope of the quantifier *few*. The final structure of the Gapping example is thus as in (81) (Johnson 2000: 109, his (24c)).

(80)

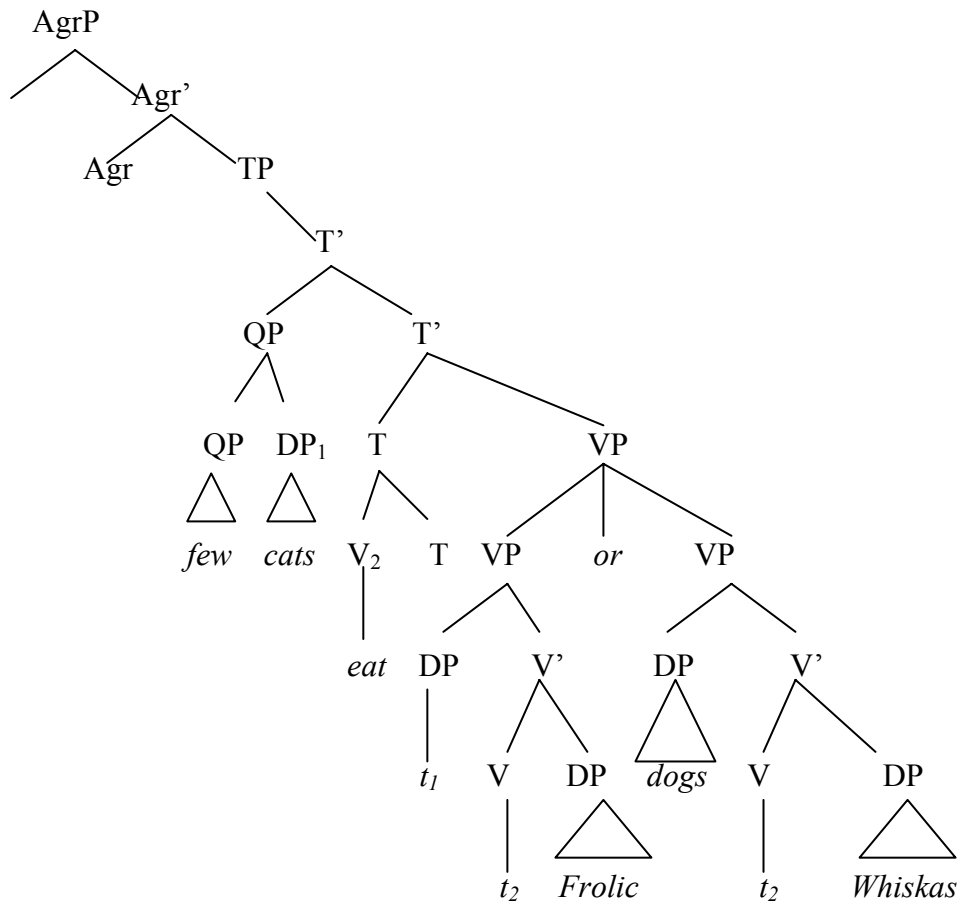

(81)

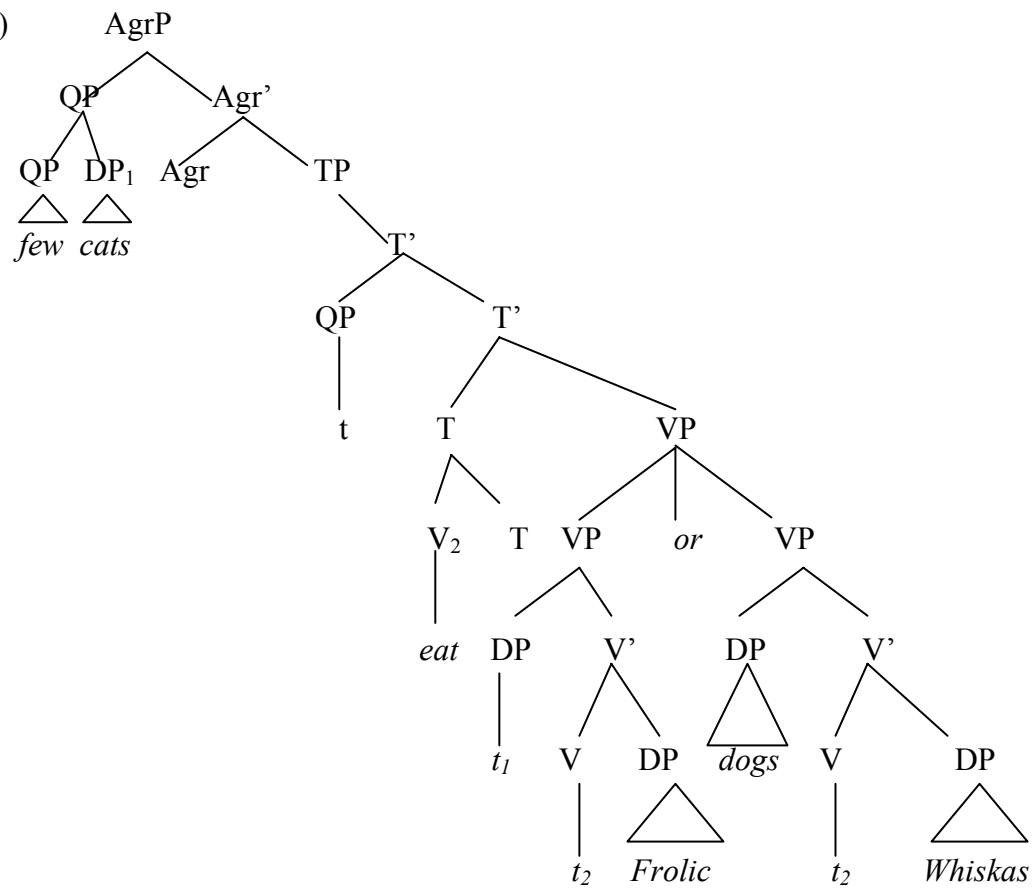

While, at first sight, it seems impossible to account for these quantifier effects in gapping with the high coordination structure that I suggested in my proposal above, there does not seem an a priori reason for us to assume that the coordination structure in Gapping necessarily has to be sentential coordination. Instead, with the approach I put forward above, we can also assume that the coordination structure is as suggested in Johnson's (2000, a.o.) analysis, i.e. the low coordination.

Following Jayaseelan (2001), who suggested that there is an information-structural layer above the VP level, which not only comprises a Focus projection (the one assumed in Pseudogapping), but also a Topic projection, thus reflecting the situation in the CP domain. Then, the Gapping derivation could actually proceed as I suggested above, with the difference that the object moves to a Focus projection above the VP level, and the subject moving past that projection into the specifier of the Topic position. Again, taking the *contrastive topic – contrastive focus* structure as background for the information structure in Gapping (cf. e.g. Gergel et. al., among others), the subject would move into a Topic position, as illustrated in (83) below (cf. also Gergel and McNay 2006a for a similar proposal, though with slightly different projections).

(82) John read a book, and Heather _ a magazine.

(83)

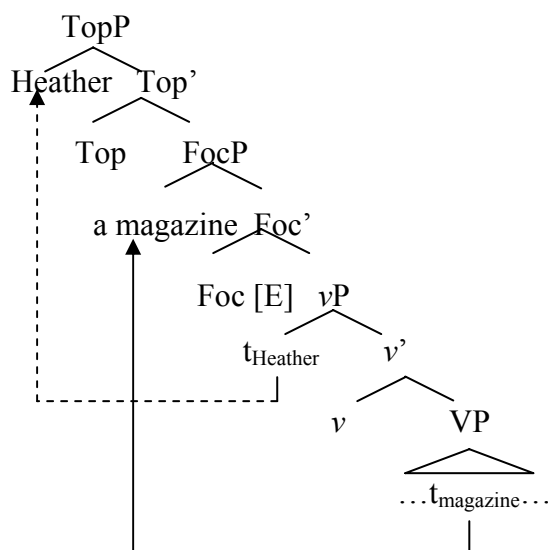

On the basis of the structure in (84), repeated from (81) above, I suggest that the coordination in Gapping is located at the TP level.¹⁶³

(84)

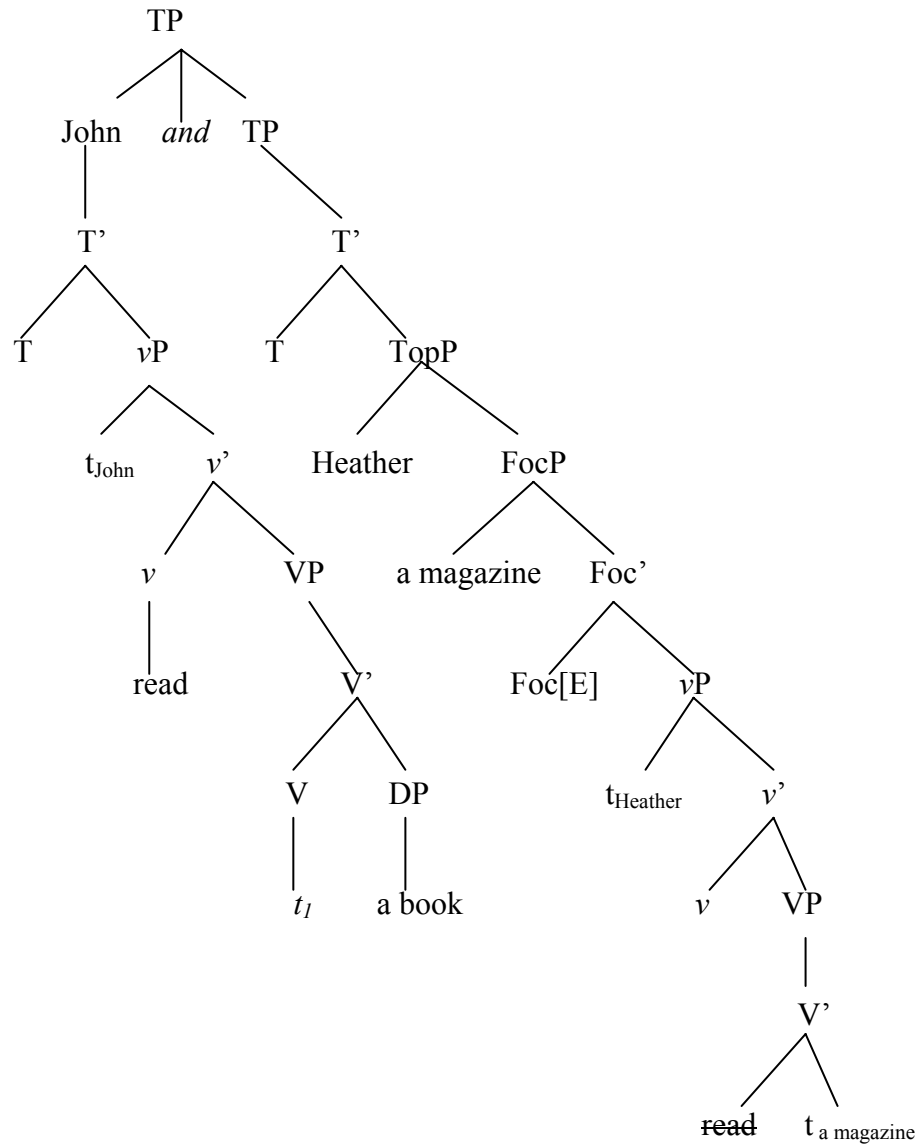

In this structure, as in Pseudogapping, the E-feature would be placed on the Focus head, thus accounting for the similarity between the two phenomena.¹⁶⁴ Therefore, the deletion of the full vP would be triggered, as assumed in Merchant (2006, 2007).

¹⁶³ But see Johnson (2006) for arguments that Gapping involves vP coordination and (if deletion at all) VP deletion. His general argumentation, however, is based on the assumption that Gapping is not an ellipsis process, that is, that it is not to be equated with the other instances discussed above. The configuration in (84) above would be more like Pseudogapping, according to the examples Johnson gives (2006: 9, his (25)), though see his (1994) account, where he assumes VP coordination (as pointed out in Zoerner and Agbayani 2000: 550).

¹⁶⁴ Whether the verb moves from V to v is irrelevant here, since the whole vP is deleted. For the sake of clarity, I have placed the verb that is subsequently elided (indicated by strikethrough font) in its base position, though nothing hinges on this assumption here.

Note that in the framework with Topic and Focus projections above the ν P layer, the coordination in Gapping could not be the ν P layer. Even if multiple specifiers were assumed to accommodate the moved object, the order between the two specifiers could not be derived if the subject stayed in situ. Moving the subject out of the ν P, either in the traditional manner, to [Spec,TP], or to [Spec,TopP], as suggested above, requires a landing site that is outside of the coordination. At present, I do not see how this could be reconciled with the aim of having a low coordination in Gapping, and therefore have to leave this intricacy of the Gapping derivation for future research.^{165,166}

In the remainder of this chapter, I will show that the mechanism proposed for the instances of deletion in the VP domain and the CP domain can even be extended to cover cases of deletion in the DP, that is, NP Ellipsis.

9.7. NP Ellipsis

Recall from the data in chapter 2 that NP Ellipsis can have different remnants, which are illustrated again in (85) (quantifiers), (86) (numerals), (87) (demonstratives), and (88) (possessives).

(85) John called out the children's names, and many/few/all/each/some [e] answered.
(Lobeck 1995: p. 45)

(86) The students attended the play but two [e] went home disappointed.
(Kester 1996: p. 195)

¹⁶⁵ Neither do I have anything to say about the auxiliary, and the lack of insertion in Gapping, but see Gengel and McNay 2006a for discussion that bears on this issue. As I do not have any solution that would explain both the absence of auxiliary insertion in Gapping and the presence of the auxiliary in Pseudogapping, I leave this matter for further research.

¹⁶⁶ A further issue problem arises with respect to the Focus projections assumed (Artemis Alexiadou, p.c.). If one were to assume a derivation of Gapping that runs strictly parallel to the derivation of Pseudogapping, a lower focus position should be generated to accommodate movement of the object out of the VP. Thus, we would end up with two focus projections, one lower, and one higher, which is clearly not desirable in terms of checking information-structural features. This problem, however, could also be overcome with the assumption of long object movement to the focus projection in the CP. Obviously this would make the E-feature on T the only E-feature in Gapping, i.e. no additional E-feature in the VP needs to be assumed.

(87) Although she might order these [e], Mary won't buy those books on art history.

(Kester 1996: p. 195)

(88) Although John's friends were late to the rally, Mary's [e] came on time.

(Kester 1996: p. 194)

9.7.1. A Focus Projection in DP

On the basis of Dutch data, given in (89), Corver & van Koppen (2006) assume a focus projection in DP, as illustrated in (90) below.

(89) Over konijnen gesproken... (Talking about rabbits...)

Ik heb gisteren een zwart-e _ zien lopen.

I have yesterday a black see walk

'I have seen a black one yesterday.'¹⁶⁷

(90)¹⁶⁸

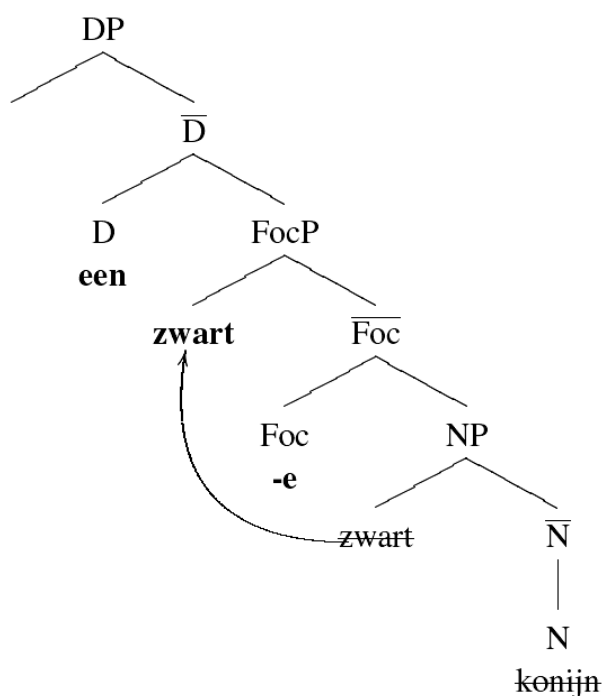

¹⁶⁷ Adapted from Corver & van Koppen (2006), their example (27), which is classified as *regional Dutch*.

¹⁶⁸ Based on Corver & van Koppen's (2006) structure, except for the base-generation of the adjective in [Spec,NP] – they use an additional XP above NP.

As can be seen in the structure in (90), they assume movement of the adjective, which bears a [+F]-feature, to [Spec,FocP]. The *e*-affix is a focus marker and spells out Foc. At the PF level, the sister of the Focus head is subsequently elided (following Merchant 2001).

In English, too, there is some focus on the adjectival remnant in NP Ellipsis, as indicated in (91) (where capitals indicate focus):

(91) I saw a **BLACK** one yesterday.

The derivation of the English example could thus proceed exactly parallel to the Dutch example. As in Corver & van Koppen's (2006) account, the adjective moves to [Spec,FocP], but in my analysis, it does so because it is focused and thus cannot remain inside the NP, which is specified for deletion. The relevant derivation for the sentence in (91) is given below, with the E-feature starting out on N (as in the analysis I suggested in Gengel 2006a, and subsequent work), which, of course, could also be inserted directly on the head of the focus projection, to delete the complement. ¹⁶⁹

(92)

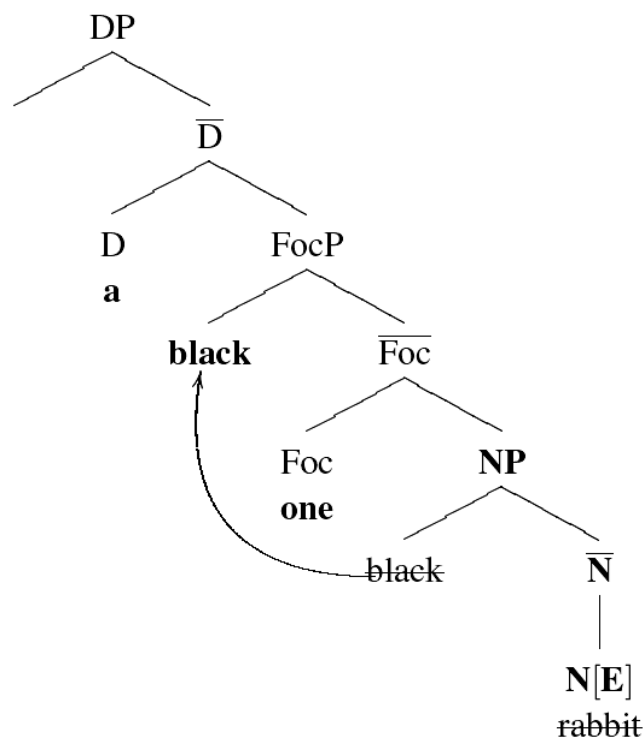

¹⁶⁹ I leave out the debate about the status of English one in the example above for clarity of exposition, but see Gengel and McNay (2006b) for details on how to handle this issue.

To accommodate this derivation in a framework based on phases, I assume the following.

9.7.2. Phase-Based Deletion in the DP

Following the basic structure in Adger (2003), and ideas in Butler (2004), the DP, like the VP, also contains a functional head, namely *nP* above NP (like *vP* on top of VP). This is schematised in (93) below.

(93)

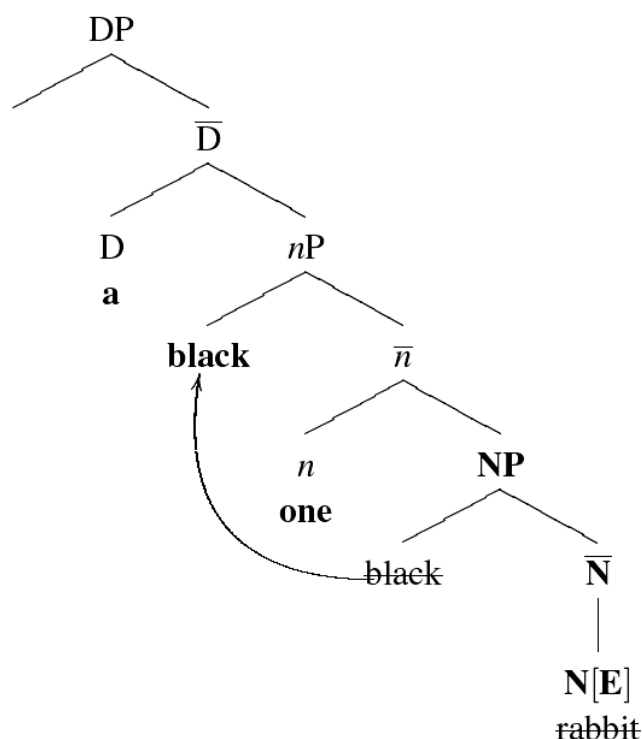

A structure like the one given in (93) has the following advantages. If [Spec,*nP*] hosts adjectives, NPE could indeed be deletion of NP, instead of N-bar deletion (which, in essence, is also a conclusion that can be derived with the Focus projection in the account above).¹⁷⁰

Moreover, the process of *one*-insertion in *n* can be explained as follows. Since *n* bears the E-feature, the noun does not move from N to *n*. To realise the agreement features on *n*,

¹⁷⁰ Presumably, if adjectives are not base-generated in [Spec,*nP*] but moved there in the course of the ellipsis derivation, this would explain the focus effects (similar to Chomsky's outer specifier system in Chomsky 2005).

however, which is necessary for NP-Ellipsis to be licensed, *one* is inserted. This allows us to maintain that NP-Ellipsis can be PF-Deletion after all, and argue against a non-deletion approach as in Barbiers (1990, 2006). On the other hand, since *one* is inserted in *n*, and not in the head of a focus projection, the pronominal properties of *one* are also accounted for.

9.8. Conclusion

In this chapter, I have thus provided a uniform account of various instances of ellipsis that otherwise receive highly idiosyncratic analyses. Despite some residual problems for this analysis, I have shown that it is possible, in principle, to derive all types of ellipsis with a combination of focus movement (if there is a remnant), and a deletion process defined in terms of the E-feature.

10. Conclusion

In this dissertation I have put forward a uniform account of various instances of elliptical constructions in English. The main focus of my analysis lay on the Pseudogapping phenomenon, given again in (1) below.

(1) This should make you laugh – it did me!

On the basis that the Pseudogapping construction is closely related to two other elliptical constructions in the verb phrase domain, notably VP Ellipsis (in (2), from Lobeck 1995) and Gapping (in (3)), I have investigated approaches that have considered Pseudogapping to be an instance of Gapping, as it involves a contrastive remnant. Based on the similarities between Pseudogapping and VP Ellipsis, however, I have adopted the other type of account for my own analysis, which treats Pseudogapping as an instance of VP Ellipsis.

(2) Mary met Bill at Berkeley and Sue did too.

(3) Claire read a book, and Heather a magazine.

Ultimately, however, I have suggested that the differences between Gapping and VP Ellipsis can be built in an account that unifies the two phenomena as being both instances of ellipsis.

Obviously, adopting a VP Ellipsis-type account such as the one proposed in Lasnik (1995a, and subsequent work) entails one of the central questions that I have tried to answer in this dissertation: if Pseudogapping is VP Ellipsis, then the remaining element, such as *me* in (1) above, needs to move out of the VP before the VP is subsequently deleted. I have provided a discussion of a number of approaches that have assumed various types of movement, for instance, Heavy NP Shift, Object Shift, Dutch Scrambling, Focus movement, or a combination of movements, of Heavy NP Shift and object shift in Takahashi's (2003a) hybrid

account, and have shown that the most universal movement of the choice provided above is the focus movement type, which is considered to be leftward A-bar-movement. Thus, it not only accounts for the distribution of remnants that occur in Pseudogapping, but also for their focal properties, a dimension that has been rather neglected in the predominant approaches (it is only explicitly implemented in Jayaseelan's 2001 focus movement approach).

Moreover, the focus movement approach to Pseudogapping can be combined with the deletion operation that has been suggested in Merchant (2001). His E-feature can be implemented such that it interacts with the focus on the remnant, a condition that has not been made as explicit in Merchant's (2001) approach. The interaction between two features, that is, the E-feature which specifies a particular portion of the syntactic structure for phonological deletion, and the Focus feature, thus derives the movement and deletion analysis of Pseudogapping in terms of focus movement: focus movement only obtains if it is necessary to move contrastive material out of the phrase that is specified for deletion.

With this very general assumption, I have argued, we cannot only account for Pseudogapping but also for other types of ellipsis as well, such as Sluicing (which I will analyse as involving focus, too), Fragment answers, and, more controversially, Gapping and NP Ellipsis. The relevant Sluicing (4), Fragments (5, from Merchant 2004), and NP Ellipsis (6, from Lobeck 1995) examples are given below.

(4) I should invite someone, but I don't know **who**.

(5) a. Who did she see?

b. **John**.

(6) Although John's friends were late to the rally, **Mary's** arrived on time.

In each of these cases, the boldfaced element moves to a higher position in the structure, driven by focus, and the remainder of the phrase (the complement) can then be deleted. In chapter 9, I have illustrated in detail how this uniform account of ellipsis can be implemented.

Before reaching this analysis, I have first looked at previous approaches of Pseudogapping, to show where the focus movement account might be superior. In particular, I claimed that a hybrid approach, as suggested in Takahashi (2003a, and subsequent work), is not necessary, since all remnants could equally well be derived via leftward movement.

I have further argued that the EPP in the Pseudogapping derivation does not fulfil the role it was intended to play, as it cannot properly account for the information-structural peculiarities of Pseudogapping, which need not be assumed in the other cases the EPP is presumed to cover. I thus concluded that the EPP needs to be coupled with an additional requirement, notably contrast, which then led me to assume that, depending on the exact syntactic configuration that is assumed for the vP layer (especially in terms of phases), the EPP requirement which moves the remnant to a specifier position can be replaced with a focus feature that accounts for the movement of the remnant in Pseudogapping.

In the attempt to unify several instances of elided structures, a further issue demanded attention, especially in the view of recent work on voice alternations in ellipsis. In Merchant's (2007) analysis, Pseudogapping is conceived to involve vP deletion, as it does not allow voice alternations, and VP Ellipsis is regarded as traditional VP deletion, as it permits voice changes between the antecedent and the elided clause. As this matter is far from settled yet, however, given that the judgements of the data are quite subtle, I have argued that for the time being, Pseudogapping and VP Ellipsis should be regarded to both involve VP deletion, with the only difference that the Pseudogapping remnant needs to vacate the VP prior to ellipsis.

This not only unifies Pseudogapping and VP Ellipsis in terms of the size of the deletion site, but also with respect to verb movement or lack of verb movement, a problem that became apparent as such in Lasnik's (1995a, a.o.) approach. If Pseudogapping, and, by extension, VP Ellipsis, involved verb movement from V to v , the deletion site must either be vP , or verb movement cannot take place in these constructions. I proposed that the latter strategy applies, and that the E-feature on v blocks verb movement to this position in both VP Ellipsis and Pseudogapping.

In a similar vein as Pseudogapping, Sluicing, Fragment answers, and Gapping can also be shown to involve movement of their respective remnants out of phrases that are specified for

deletion. Crucially, in these instances, it is the TP that is targeted for deletion, an observation that I exploit in the translation of the ellipsis process in English into a phase-based framework.

It seems that the phase theory, which is built on the ν P phase and the CP phase (though I have provided a potential extension to the DP in chapter 9), with its Spell-out mechanism, is amenable to an account of ellipsis that makes use of specific Spell-out domains. More specifically, I argue that Pseudogapping and VP Ellipsis involve the deletion of the domain of the ν P phase, thus being an instance of non-Spell-out. Similarly, the Spell-out of the TP, which is considered to be the domain of the CP in Chomsky's (2001, 2005) analysis, is prohibited in elliptical constructions that target the higher part of the clause, notably, Sluicing, Fragments, and Gapping. Finally, I show that if the DP were conceived to be a phase as well, the relevant domain would fail to spell-out in NP Ellipsis.

In sum, the mechanism I developed to account for the Pseudogapping construction provides an entirely new perspective on the potential for unifying several, if not all elliptical phenomena, in English grammar, and leaves sufficient room to accommodate languages other than English as well. Scandinavian Pseudogapping, for instance, hitherto unattested in the literature, could also receive an account in terms of A-bar-movement (crucially, not object shift), which is predictable on the basis of my analysis.

Thus, an approach to ellipsis which is based on the interaction between focus and deletion as the main concepts (as opposed to the licensing condition approach in Lobeck 1995), and which incorporates the language-specific licensing properties on the feature that is responsible for deletion, permits us to cover a greater range of elliptical constructions than was previously possible. Not surprisingly, however, the generality of the movement and deletion mechanism in English elliptical structures comes with the prize of potential overgeneration (a problem that applies in other approaches to Pseudogapping as well). In particular, the analysis of Gapping, while it can be accommodated into an ellipsis theory, proves to remain notoriously difficult, as well as the island effects found in the comparison between the Sluicing cases and VP Ellipsis cases. While I believe that both of these issues may be solved, a proper analysis of these problems will have to await future research.

References

- Agbayani, B., and E. Zoerner. 2004. Gapping, Pseudogapping and Sideward Movement. *Studia Linguistica* 58(3), 185-211.
- Alexiadou, A., and E. Anagnostopoulou. 1997. Toward a uniform account of scrambling and clitic doubling. In *German: Syntactic Problems – Problematic Syntax* [Linguistische Arbeiten 374], W. Abraham and E. van Gelderen (eds), 142-161. Tübingen: Niemeyer.
- Alexiadou, A., and E. Anagnostopoulou. 1998. Parametrizing AGR: Word order, V-movement and EPP-checking. *Natural Language and Linguistic Theory* 16: 491-539.
- Alexiadou, A., and E. Anagnostopoulou. 2001. The Subject-in-Situ Generalization and the Role of Case in Driving Computations. *Linguistic Inquiry* 32(2), 193-231.
- Anagnostopoulou, E. 2002. Movement across phonologically visible categories. Ling-Lunch, MIT.
- Baltin, M. 2000. Implications of Pseudo-Gapping for Binding and the Representation of Information Structure. Ms., New York University.
- Baltin, M. 2003. The interaction of ellipsis and binding: implications for the sequencing of Principle A. *Natural Language and Linguistic Theory* 21: 215-246.
- Barss, A., and H. Lasnik. 1986. A Note on Anaphora and Double Objects. *Linguistic Inquiry* 17:347-354. ...
- Barss, A. 2001. Syntactic Reconstruction Effects. In Mark Baltin and Chris Collins (edd.), *The handbook of contemporary syntactic theory*, Cambridge, MA: Blackwell.

- Belletti, A., and U. Shlonsky. 1995. "The order of verbal complements: A comparative study". *Natural Language and Linguistic Theory* 13: 489-526.
- Boeckx, C. 2000. An additional note on Pseudogapping. In *Ellipsis in Conjunction*, ed. K. Schwabe, and N. Zhang. 117-132. Tuebingen, Niemeyer.
- Busquets, J., and P. Denis. 2006. L'ellipse modale en Français : le cas de *devoir* et *pouvoir*. Ms., Université Bordeaux-3, University of Texas at Austin
- Butler, Jonny. 2004. *Phase Structure, Phrase Structure, and Quantification*. PhD Thesis, University of York.
- Chomsky, N. 1993. *A Minimalist Program for Linguistic Theory*. Cambridge, MA: MIT Occasional Papers in Linguistics 1, MITWPL.
- Chomsky, N. 1995. *The Minimalist Program*. Cambridge, MA: MIT Press.
- Chomsky, Noam. 2001. Derivation by phase. In Michael Kenstowicz (ed.), *Ken Hale: A Life in Language*. Cambridge, MA: MIT Press, 1-52.
- Chomsky, Noam. 2005. On Phases. Ms., MIT.
- Chomsky, N., and H. Lasnik. 1993. The theory of principles and parameters. In J. Jacobs et al. (eds), *Syntax: An International Handbook of Contemporary Research* [Volume 1]. 506-569. Berlin/New York: de Gruyter.
- Chung, S., W. A. Ladusaw, and J. McCloskey. 1995. Sluicing and Logical Form, *Natural Language Semantics* 3, 239-282.
- Collins, C. 1996. VP Internal Structure and Object Shift in Icelandic. In: *Linguistic Inquiry* 27.3, 391-444 (with H. Thráinsson).

- Coppock, E.. 2001. Gapping: In Defense of Deletion. In *Proceedings of the 37th Annual Conference of the Chicago Linguistic Society*, 133-148. Chicago Linguistic Society, University of Chicago, Ill.
- Corver, N., & M. van Koppen. 2006. A Focus projection in the left periphery of DP: evidence from noun ellipsis. Talk presented at the *Edges in Syntax Conference*, Cyprus, May 2006.
- Craenenbroeck, J. van. 2004. *Ellipsis in Dutch dialects*. LOT publications.
- Craenenbroeck, Jeroen van, and Aniko Liptak. 2006. Silence in the left periphery: The cross-linguistic syntax of Sluicing. Paper presented at the Edges in Syntax Conference, Cyprus College, May 2006.
- Fanselow, G. 1995. -- Talk given at the University of Massachusetts, Amherst.
- Fiengo, R., and R. May. 1994. *Indices and Identity*. Cambridge, MA: MIT Press.
- Fox, D. and H. Lasnik. 2003. Successive cyclic movement and island repair: The difference between Sluicing and VP Ellipsis. *Linguistic Inquiry* 34:143-154.
- Fox, D, and D. Pesetsky. 2003. Cyclic Linearization and the Typology of Movement. Ms., MIT. [http://web.mit.edu/linguistics/www/fox/July_19_handout.pdf]
- Fox, D. 2000. *Economy and Semantic Interpretation*. Cambridge, MA: MIT Press.
- Francis, D. 2005. *Shattered*. Pan Books.
- Gengel, K. 2002. *Pseudogapping in English Grammar*. Staatsexamensarbeit, University of Tuebingen.
- Gengel, K. 2006a. Contrastivity and ellipsis. In L. Mackie and A. McNay (edd.), *Online Proceedings of LingO – The First University of Oxford Postgraduate Conference in Linguistics*.

- Gengel, K. 2006b. Head Deletion and Ellipsis. *Proceedings of the Conference on Ellipsis (Actes du Colloque sur l'Ellipse)*, St. Etienne.
- Gengel, K. 2006c. The Role of Contrast in Deletion Processes. *Proceedings of the Penn Linguistics Colloquium (PLC 30)*, Philadelphia.
- Gengel, K. 2006d. Une approche contrastive aux pronoms résomptifs en interaction avec les anaphores zéro. *Proceedings of the Conference on Anaphors (Actes du Colloque sur l'Anaphore)*, Tunis, Tunisia.
- Gengel, K. 2006e. Auxiliaries, Contrast and Ellipsis. *Proceedings of the CamLing Conference*, C. Chang, E. Dugarova, I. Theodoropoulou, E. Vilar Beltrán and E. Wilford (eds.), Cambridge, England.
- Gengel, K. to appear a. Focus, Exhaustivity, and Deletion in English Pseudogapping. To appear in *Proceedings of the Colloquium on Generative Grammar (CGG XIV)*, Madrid.
- Gengel, K. to appear b. Object Shift and Pseudogapping in the Scandinavian Languages. To appear in *Proceedings of ConSOLE XIV*.
- Gengel, K. to appear c. Phases and Ellipsis. In E. Efner, and M. Walkow (eds.), *Proceedings of 37th meeting of the North East Linguistic Society, GLSA: University of Massachusetts, Amherst*.
- Gengel, K., and A. McNay 2006a. Recursive Information-Structural Layers in Syntax: Evidence from the vP Layer. In *Proceedings of the CamLing Conference*, C. Chang, E. Dugarova, I. Theodoropoulou, E. Vilar Beltrán and E. Wilford (eds.), Cambridge, England.
- Gengel, K., and A. McNay. 2006b. Information Structure at the Phase Level: Ellipsis in the DP. Paper presented at the *Workshop on DP-Internal Information Structure: Topic, Focus, and other Illocutionary Forces*. University of Utrecht.

- Gergel, R., Gengel, K., and S. Winkler. 2007. Ellipsis and inversion: A feature-based focus account, in K. Schwabe & S. Winkler (edd.) *On Information Structure, Meaning, and Form*. Amsterdam/Philadelphia: John Benjamins. 301-322.
- Holmberg, A., and C. Platzack. 1995. *The Role of Inflection in Scandinavian Syntax*. Oxford: Oxford University Press.
- Jayaseelan, K. A. 1990. Incomplete VP Deletion and Gapping. *Linguistic Analysis* 20: 64-81.
- Jayaseelan, K. A. 2001. IP-Internal topic and focus phrases. *Studia Linguistica* 55(1): 39-75.
- Johnson, K. 1991. Object positions. *Natural Language and Linguistic Theory* 9: 577-636.
- Johnson, K. 1994. Bridging the Gap. Ms., University of Massachusetts, Amherst, MA.
- Johnson, K. 1996a/2000. When verb phrases go missing. State-of-the-article, *Glott International*, Vol. 2, Issue 5, 75-103. 2000 "When Verb Phrases go missing." In *The first Glott International state-of-the-article book*, Mouton de Gruyter, Lisa Cheng and Rint Sybesma (eds.). 75-103.
- Johnson, Kyle. 1996b/2003. In search of the middle field. Ms., University of Massachusetts, Amherst.
- Johnson, K. 2000. Gapping determiners. In: *Ellipsis in Conjunction*, Niemeyer Publishers, Kerstin Schwabe and Nina Zhang (eds.), pp. 95-115.
- Johnson, K. 2001. What VP-Ellipsis can do, what it can't, but not why. In *The Handbook of Contemporary Syntactic Theory*, M. Baltin and C. Collins (eds), 439-479. Oxford: Blackwell Publishers.
- Johnson, K. 2004. How to be Quiet. In: Proceedings of CLS 40.
- Johnson, K. 2005. Ellipsis as Phonological Projections. Paper presented at the University of Stuttgart, January 2005.

- Johnson, K. 2006. Gapping is not (VP) Ellipsis. Paper submitted to *Linguistic Inquiry*.
- Jónsson, J. 1996. *Clausal Architecture and Case in Icelandic*. Doctoral Dissertation, University of Massachusetts, Amherst.
- Kayne, R. 1985. Principles of particle constructions. In *Grammatical Representations*, J. Guéron, H.-G. Obenauer and J.-Y. Pollock. Dordrecht: Foris Publications.
- Kennedy, C., and J. Merchant. 1997. Attributive Comparatives and Bound Ellipsis. UCSC Linguistics Research Center Report LRC-97-3.
- Kennedy, C., and J. Merchant. 2000. Attributive Comparative Deletion, *Natural Language and Linguistic Theory* 18: 89-146.
- Kennedy, C. 2003. Ellipsis and Syntactic Representation. In: Schwabe, K. and S. Winkler (eds.) *The Syntax-Semantics Interface: Interpreting (Omitted) Structure*. Amsterdam: John Benjamins.
- Kester, E. 1996. *The nature of adjectival inflection*. PhD. thesis. University of Utrecht.
- Kim, J.S. (1997). *Syntactic focus movement and ellipsis: A minimalist approach*. Doctoral dissertation, University of Connecticut, Storrs.
- Kiss, K. E. 1998. Identificational Focus versus Information Focus. *Language* 74, 245-273.
- Koizumi, M. 1995. *Phrase Structure in Minimalist Syntax*, Ph.D. Dissertation, MIT.
- Kratzer, A. 1991. The representation of focus. In *Semantik/Semantics: An International Handbook of Contemporary Research*, A. von Stechow and D. Wunderlich (eds), 804-825. Berlin: de Gruyter.
- Larson, R.K. 1988. On the double object construction. *Linguistic Inquiry* 19: 335-391.

- Lasnik, H. 1995. A Note on Pseudogapping. In: *Papers on Minimalist Syntax*, MIT Working Papers in Linguistics 27, 143-163.
- Lasnik, H. 1999a. Pseudogapping puzzles. In S. Lappin and E. Benmamoun (eds.) *Fragments: Studies in Ellipsis and Gapping*. Oxford University Press, pp. 141-174.
- Lasnik, H. 1999b. On Feature Strength: Three Minimalist Approaches to Overt Movement. *Linguistic Inquiry* 30(2), 197-217.
- Lasnik, H. 1999c. Chains of arguments. In S. Epstein and N. Hornstein (eds.) *Working Minimalism*. MIT Press. 189-215.
- Lasnik, H. 1999d. A Note on Pseudogapping. In: Lasnik, H. *Minimalist Analysis*. Oxford: Blackwell. 151-174.
- Lasnik, H. 2001a. Subjects, objects, and the EPP. In W. D. Davies and S. Dubinsky (eds.) *Objects and Other Subjects: Grammatical Functions, Functional Categories, and Configurationality*. Kluwer, pp. 103-121.
- Lasnik, H. 2001b. A Note on the EPP. *Linguistic Inquiry* 32: 356-362.
- Lasnik, H. 2002. Feature movement or agreement at a distance? In A. Alexiadou, E. Anagnostopoulou, S. Barbiers and H.-M. Gaertner (eds.) *Dimensions of Movement*. John Benjamins. 189-208.
- Lasnik, H. 2004. A-Movement, the EPP, and the Organization of the Grammar. Seminar taught at the University of Stuttgart, June 2004.
- Lasnik, H. 2005a. How to Evade Moving Violations. Course Material, LSA Institute, MIT/Harvard University, July/August 2005.
- Lasnik, H. 2005b. What is the EPP? Handout, Glow Colloquium, April 2005.

- Lasnik, H. and M. Saito. 1991. On the subject of infinitives. In L. Dobrin, L. Nichols, and R. Rodriguez (eds.) *Papers from the 27th Regional Meeting of the Chicago Linguistic Society*. 324-343.
- Lasnik, H. 2003, and Myung-Kwan Park. The EPP and the Subject Condition under Sluicing. *Linguistic Inquiry* 34(4), 649-660.
- Lebeaux, D. 1988. Language Acquisition and the Form of Grammar. Doctoral Dissertation University of Massachusetts, Amherst.
- Lechner, W. 2004. *Ellipsis in Comparatives*. Berlin: Mouton de Gruyter.
- Levin, N. 1978. Some Identity-of-Sense Deletions Puzzle Me. Do They You? *CLS* 14, 229-240.
- Levin, N. 1986. *Main Verb Ellipsis in Spoken English*. New York/London: Garland.
- Levin, B., and M. Rappaport Hovav. 2005. *Argument Realization*, Cambridge University Press, Cambridge, UK.
- Lobeck, A. 1995. *Ellipsis : Functional Heads, Licensing, and Identification*. New York / Oxford. Oxford University Press.
- Lobeck, A. 1999. VP Ellipsis and the minimalist program: some speculations and proposals. In *Fragments: Studies in Ellipsis and Gapping*, S. Lappin and E. Benmamoun (eds). 98-124. Oxford/New York: Oxford University Press.
- Merchant, J. 2001. *The Syntax of Silence: Sluicing, Islands and the Theory of Ellipsis*. Oxford: Oxford University Press.
- Merchant, J. 2004. Fragments and ellipsis. *Linguistics and Philosophy* 27.6: 661-738.
- Merchant, J. to appear. Variable island repair under ellipsis. In K. Johnson (ed.), *Topics in ellipsis*. Cambridge: Cambridge University Press.

- Merchant, J. 2006/2007a. An asymmetry in voice mismatches in VP-ellipsis and Pseudogapping. Ms., University of Chicago. To be published in *Linguistic Inquiry*.
- Merchant, J. 2007b. Voice and Ellipsis. Ms., University of Chicago, Chicago, Ill.
- Mohr, S. 2005. *Clausal Architecture and Subject Positions*. Amsterdam: John Benjamins.
- Nunes, Jairo. 2001. Sideward movement. *Linguistic Inquiry* 32:303–344.
- Ottósson, K. G. 1991. Icelandic double objects as small clauses. *Working Papers in Scandinavian Syntax* 48, pp. 77-97.
- Pesetsky, D. 1995. *Zero Syntax*. Cambridge, MA: MIT Press.
- Richards, N. 2001. *Movement in language: Interactions and architectures*. Oxford: Oxford University Press.
- Rizzi, L. 1997. The fine structure of the left periphery. In *Elements of Grammar*, L. Haegeman (ed), 281-337. Dordrecht: Kluwer.
- Rochemont, M. 1978. *A theory of stylistic rules in English*. PhD Dissertation, University of Massachusetts.
- Rooth, M. 1985. *Association with Focus*. PhD Thesis. University of Massachusetts, Amherst.
- Rooth, M. 1992a. A Theory of Focus Interpretation. *Natural Language Semantics* 1: 75 - 116.
- Rooth, M. 1992b. Ellipsis Redundancy and Reduction Redundancy. In *Proceedings of the Stuttgart Ellipsis Workshop*, S. Berman and A. Hestvik (eds), Stuttgart.
- Ross, J. 1969. Guess who? In R. Binnick, A. Davison, G. Green, and J. Morgan (eds.), *Papers from the 5th regional meeting of the Chicago Linguistic Society*, 252-286. CLS, Chicago Ill. 24.

- Sag, I. 1976. *Deletion and Logical Form*. PhD Thesis, University of Massachusetts, Amherst.
- Sauerland, U. 1998. *The Meaning of Chains*. Doctoral Dissertation, MIT, Cambridge, MA.
- Schwarzschild, Roger. 1999. GIVENness, Avoid F and other Constraints on the Placement of Focus. *Natural Language Semantics*, 7(2): 141-177.
- Stechow, A. von. 1991. Current issues in the theory of focus. In *Semantik/Semantics: An International Handbook of Contemporary Research*, A. von Stechow and D. Wunderlich (eds), 804-824. Berlin, de Gruyter.
- Stowell, T. 1981. *The origins of phrase structure*. PhD Dissertation, MIT, Cambridge, MA.
- Szabolcsi, A. 1981. The semantics of topic-focus articulation. In *Formal Methods in the Study of Language*, J. Groenendijk, T. Janssen and M. Stokhof (eds), 513-541. Amsterdam: Mathematisch Centrum.
- Szendroï, K. 2001. *Focus and the syntax-phonology interface*. PhD Thesis, University College, London.
- Takahashi, S. 2003a. Pseudogapping: The View from Scandinavian Languages. *Comparative Germanic Syntax Workshop 18*. University of Durham, September 18th-20th.
- Takahashi, S. 2003b. Pseudogapping and Cyclic Linearization. *NELS 34*. Stony Brook University, November 7th-9th.
- Takahashi, S. 2004a. Pseudogapping and Cyclic Linearization. In *Proceedings of NELS 34*, 571-585. Amherst, Mass.: GLSA Publications.
- Takahashi, S. 2004b. Dimensions of Focus Effects in Ellipsis. Workshop Dimensions of Focus at *The Twenty Second National Conference of The English Linguistic Society of Japan*. (Aniko Csirmaz (Massachusetts Institute of Technology), Ken Hiraiwa (Massachusetts Institute of Technology) and Sachiko Kato (Massachusetts Institute of Technology)). Dokkyo University, November 13th-14th.

- Tancredi, C. 1992. Deletion, deaccenting and presupposition. PhD Dissertation, MIT, Cambridge, MA.
- Williams, E. 1977. Discourse and logical form. *Linguistic Inquiry* 8, 101-139.
- Winkler, S., and K. Schwabe. 2003. Exploring the interfaces from the perspective of omitted structures. In *The interfaces: deriving and interpreting omitted structures*, K. Schwabe and S. Winkler (eds), 1-26. Amsterdam: John Benjamins.
- Winkler, S. 2005 [2003]. *Ellipsis and Focus in Generative Grammar*. (Studies in Generative Grammar 81.) Series Editors: Harry van der Hulst, Henk van Riemsdijk and Jan Koster). Berlin/New York: de Gruyter.
- Zoerner, E., and B. Agbayani. 2000. Unifying Left-Peripheral Deletion, Gapping and Pseudogapping. In: *Proceedings of CLS 36: The Main Session (2000)*: 549-561.

German Abstract

In der vorliegenden Dissertation habe ich dafür argumentiert, dass verschiedene Ellipsen-Konstruktionen im Englischen eine einheitliche Analyse erhalten können. Das Phänomen, dem ich bei der Entwicklung dieser Analyse in meiner Dissertation die meiste Aufmerksamkeit gewidmet habe, ist die Pseudogapping-Konstruktion in (1), wobei das [e] in der wörtlichen deutschen Übersetzung für elidiertes (d.h. phonologisch getilgtes) Material steht.

(1) This should make you laugh – it did me!

Dies sollte dich zum Lachen bringen – es hat mich ([e]).

‘= ... es hat mich zum Lachen gebracht.’

Pseudogapping ist eng mit zwei anderen elliptischen Strukturen verwandt, die ebenfalls durch die Tilgung des Verbs gekennzeichnet sind, die VP Ellipse in (2) (das Beispiel ist von Lobeck 1995), und die Gapping-Konstruktion in (3).

(2) Mary met Bill at Berkeley and Sue did too.

Mary traf Bill in Berkeley und Sue [tat] auch.

(3) Claire read a book, and Heather a magazine.

Claire las ein Buch, und Heather eine Zeitschrift.

Aufgrund der oberflächlichen Ähnlichkeit der Strukturen miteinander wurde Pseudogapping oft als eine Variante der Gapping-Konstruktion behandelt, da es wie Gapping auch ein kontrastives Element aufweist, das der getilgten Phrase folgt. Diese Analyse habe ich jedoch auf Grund der Beobachtung verworfen, dass Pseudogapping der VP Ellipsen-Struktur wesentlich ähnlicher ist.

Als Folge dieser angenommenen Verwandtschaft des Pseudogappings mit der VP Ellipsen-Konstruktion ergibt sich eine spezifische Fragestellung, der ich in dieser Dissertation nachgehen werde, nämlich die Frage nach der Natur der Objekt-Bewegung aus der VP heraus, die wiederum anschließend, wie für die VP-Ellipsen-Konstruktion angenommen, auf der phonologischen Ebene getilgt wird. Ich werde zu diesem Zweck einige theoretische Ansätze in der Literatur betrachten, die unter anderem Heavy NP Shift, Object Shift, Scrambling wie im Holländischen oder Fokusbewegung angenommen haben, oder eine Kombination aus Heavy NP Shift und Object Shift, wie in Takahashis hybrider Theorie (Takahashi 2003). Ich werde zeigen, dass die Fokusbewegung die umfassendste Bewegung darstellt, die somit für alle Arten von kontrastiven Remnants im Pseudogapping in Frage kommt. Damit lässt sich überdies nicht nur die Vielfalt an möglichen Remnants im Pseudogapping erklären, sondern auch, weshalb diese Remnants eine wahrnehmbare Fokussierung erfahren. Diese letztgenannte Dimension wurde in den bisherigen Analysen leicht vernachlässigt, und explizit nur in Jayaseelans Analyse (Jayaseelan 2001) angenommen.

Mit Hilfe dieser Fokusbewegung im Pseudogapping kann nun eine Verbindung mit dem Tilgungsprozess in elliptischen Konstruktionen angenommen werden, auf der Basis von Merchants E-feature (Merchant 2001). Dieses E-feature kann nun dergestalt eingesetzt werden, dass es mit dem Fokus auf dem Remnant in Pseudogapping interagiert, was eine Erweiterung von Merchants Analyse darstellt. Die Analyse, die ich hier vorlege, lässt sich damit so zusammenfassen: das E-feature spezifiziert einen Teil der syntaktischen Struktur für die Tilgung, so dass der so spezifizierte Bereich auf der phonologischen Ebene getilgt werden kann. Sobald sich jedoch noch kontrastiertes oder fokussiertes Material in der Domäne des E-features befindet, muss dieses Material aus der entsprechenden Phrase herausbewegt werden, damit die Tilgung stattfinden kann. Diese Fokusbewegung ist daher durch das E-feature erst ermöglicht, und erklärt somit, warum im Englischen diese Fokusbewegung in nicht-elliptischen Kontexten nicht stattfindet.

Mittels dieser sehr grundlegenden Annahme können nun nicht nur Pseudogapping-Fälle, sondern auch andere elliptische Konstruktionen erklärt werden, wie zum Beispiel Sluicing (4), fragmentarische Antworten (5, Merchant 2004), und NP Ellipse (6, Lobeck 1995).

(4) I should invite someone, but I don't know **who**.

Ich sollte jemanden einladen, aber ich weiß nicht, wen.

(5) a. Who did she see?

b. **John**.

(6) Although John's friends were late to the rally, **Mary's** arrived on time.

Obwohl Johns Freunde zu spät zum Treffen kamen, waren Marys _pünktlich.

In jedem der oben genannten Beispiele kann nun angenommen werden, dass das fettgedruckte Element sich in der syntaktischen Struktur nach oben bewegt, durch die Fokusbewegung, und dass der Rest der Struktur anschließend getilgt werden kann.

Daher findet die Analyse, die ich auf der Basis von Pseudogapping entwickelt habe, ein weites Anwendungsfeld, da es nicht nur viele, vielleicht sogar alle, Ellipsen-Phänomene im Englischen erklären kann, sondern auch genug Raum für übersprachliche Variation lässt. Da der Mechanismus, den ich vorgeschlagen habe, auf universellen Prinzipien fußt, nämlich der Interaktion von Fokus und Tilgung, die in jeder elliptischen Struktur gegeben zu sein scheinen, und überdies die sprachspezifischen Unterschiede in der Lizenzierung von Ellipsen in dem Feature verankert, das für die Tilgung verantwortlich zeichnet, wird es möglich, eine große Bandbreite an elliptischen Konstruktionen zu analysieren, was vorher in diesem Umfang, das heißt, ohne die Einbeziehung der syntaktischen Fokusbewegung, nicht möglich war.